

Under the rule of Massachusetts General Law Ch. 30, 39M  
The City of Waltham

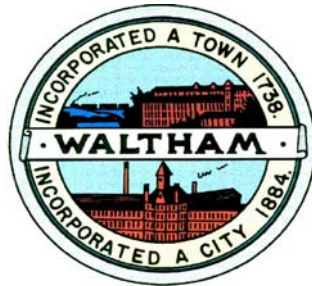

**Invites  
Interested Parties  
To propose the best offer and or bid  
For the service or product herewith described:**

**Sump Pump Amnesty Program, Contract #2, for  
Areas 5B, 5D, and 15  
Contract Number 0130620**

**The bid opening will be held: Wednesday July 31, 2013 at 10:00 AM**  
**Pre-Bid Meeting and Site inspection: Monday July 22, 2013 at 1:00 PM**  
*(Meet at the Engineering Department 119 School Street, Waltham)*  
***Last day for Questions: Noon Wednesday July 24, 2013***

**Engineers:** SDE, Inc  
354 Merrimack Street  
Lawrence, MA 01843  
**Stacy DePasquale**, President

SSV Engineering Inc.  
609 Winter Street  
Framingham, MA 01702  
**Sam Bade**, President

## TABLE OF CONTENTS

---

### **DIVISION 0- BIDDING AND CONTRACT REQUIREMENTS**

<u>Section</u>	<u>Title</u>	<u>Page</u>
00020	INVITATION TO BID	00020-1
00100	INSTRUCTIONS TO BIDDERS	00100-1
00301	BID FORM	00301-1
00480	AFFIDAVIT OF NON-COLLUSION	00480-1
00481	CERTIFICATE OF CORPORATE VOTE	00481-1
00482	CERTIFICATE AS TO PAYMENT OF STATE TAXES	00482-1
00483	CORPORATION IDENTIFICATION	00483-1
00484	STATE DEBARMENT DISCLOSURE FORM	00484-1
00485	WEEKLY PAYROLL REPORT	00485-1
00486	10 HOURS OSHA TRAINING CONFIRMATION	00486-1
00500	AGREEMENT FORMS	00500-1
00550	NOTICES (AWARD, ACCEPTANCE, PROCEED)	00550-1
00610	PERFORMANCE BOND	00610-1
00620	PAYMENT BOND	00620-1

### **DIVISION 1 - GENERAL REQUIREMENTS**

<u>Section</u>	<u>Title</u>	<u>Page</u>
01010	Summary of Work	01010-1
01024	Measurement and Payment	01024-1
01045	Cutting, Coring and Patching	01045-1
01046	Control of Work	01046-1
01080	Abbreviations and Definitions	01080-1
01110	Environmental Protection Measures	01110-1
01170	Special Provisions	01170-1
01200	Project Meetings	01200-1
01300	Submittals	01300-1
01400	Quality Assurance	01400-1
01576	Policing	01576-1
01601	Control of Materials	01601-1
01700	Work on Private Property and Site Access	01700-1
01710	Contract Closeout	01710-1

### **DIVISION 2 - SITE WORK**

<u>Section</u>	<u>Title</u>	<u>Page</u>
02020	Erosion & Sediment Control	02020-1
02100	Site Preparation	02100-1
02101	Site Investigation	02101-1

## TABLE OF CONTENTS

02140	Dewatering and Drainage	02140-1
02200	Earthwork	02200-1
02212	Rock Excavation	02212-1
02221	Trenching, Backfilling and Compaction	02221-1
02222	Clearing and Grubbing	02222-1
02273	Geotextile Fabrics	02273-1
02515	Concrete Sidewalks, Walkways and Driveway Aprons	02515-1
02576	Pavement Repair and Resurfacing	02576-1
02609	Reinforced-Concrete Drain Pipe	02609-1
02622	Polyvinyl Chloride Gravity Pipe	02622-1
02721	Storm Drainage System	02721-1
02901	Miscellaneous Work and Cleanup	02901-1
02920	Topsoil	02920-1
02945	Turf	02945-1
02950	Planting	02950-1

**DIVISION 3 - CONCRETE**

<u>Section</u>	<u>Title</u>	<u>Page</u>
03300	Cast-In-Place Concrete	03300-1
03600	Grout	03600-1

**DIVISION 14- MECHANICAL**

<u>Section</u>	<u>Title</u>	<u>Page</u>
15400	Plumbing - General Provisions	15400-1
15405	Plumbing – Demolition	15405-1
15410	Plumbing- Sump Pump Piping Systems	15410-1

TABLE OF CONTENTS

## **LIST OF APPENDICES**

---

### **APPENDIX A**

Drawings

### **APPENDIX B**

Details

### **APPENDIX C**

List of Properties and Summary of Field Inspection Findings

### **APPENDIX D**

Wetland Resource Area Maps

### **APPENDIX E**

Photographs of Properties

### **APPENDIX F**

State Wage Rates

### **APPENDIX G**

Waltham Conservation Commission Requirements

## **TABLE OF CONTENTS**

3

## **Division 0 – Bidding and Contract Requirements**

Section 00020

# Invitation to Bid

# The City of Waltham

## Purchasing Department

### REQUEST FOR BID (RFB)

Under the rules of M.G.L. Chapter 30, 39M the Chief Procurement Officer of the City of Waltham Purchasing Department hereby requests sealed bids for:

### **SUMP PUMP AMNESTY PROGRAM, CONTRACT #2 for AREAS 5B, 5D and 15 Contract Number 0130620**

Price Proposals will be received at the office of the Purchasing Agent, City Hall, 610 Main Street, Waltham MA 02452, until,

**Wednesday July 31, 2013 at 10:00 am**

At which time and place the bids will be publicly opened and read.

**Pre Bid Meeting: Monday July 22, 2013 at 1:00 Pm**

*(Meet at the Waltham Engineering Department 112 School Street, Waltham)*

Specifications and information available on line by visiting the Waltham Purchasing Department web site at [www.city.waltham.ma.us/open-bids](http://www.city.waltham.ma.us/open-bids)

If the Bidder is a corporation, state your correct corporate name and State of incorporation. If Bidder is a partnership, state names and addresses of partners. If Bidder is a trust or other legal entity, state correct names and addresses of trustees or names and address of those legally authorized to bid and enter into contracts.

**EXCEPTION OR ALTERNATES TO SPECIFICATIONS, TERMS OF SALE, AND DISCOUNTS AVAILABLE, MUST BE INCLUDED IN THE BID PRIOR TO OPENING DATE.**

**Section 00100**

# **Instruction to Bidders**



## INSTRUCTIONS FOR BIDDERS

1. READ ALL DOCUMENTS.

Bidders should familiarize themselves with all the documents contained herein; it is mandatory that all Bids be in compliance with all the provisions contained in said documents.

2. FORMS AND ATTACHMENTS.

Bids are to be completed on the forms provided ONLY and enclosed in a sealed envelope marked on the outside "BID (title)" and the name and address of bidder. Attachments submitted in addition to the Waltham Purchasing Department produced forms may not be considered.

3. PRINTED OR TYPED RESPONSE.

All information must be typewritten or printed in ink, including the price the bidder offers in the space as provided on the bid form.

4. CORRECTIONS.

Bids that are submitted containing cross outs, white outs or erasures, will be rejected. All corrections or modifications to the original bid are to be submitted in a separate envelope, properly marked on the outside, "CORRECTION/ MODIFICATION TO BID (title)" and submitted prior to the bid opening.

ALL DOCUMENTS SUBMITTED WITH YOUR RESPONSE WILL BE  
INCORPORATED INTO THE CONTRACT.

5. PRICE IS ALL INCLUSIVE.

Bid prices shall encompass everything necessary for furnishing all items, materials, supplies or services as specified, and in accordance with the specifications, including proper packing, cost of delivery, and in the case of services, completion of same, as per specifications.

6. PRICE DISCREPANCY.

In the event of a discrepancy between the Unit Price and the Extension, the Unit Price shall prevail.

7. EXPLANATIONS, EXCEPTIONS

Explanations, exceptions or other information pertinent to the specifications may be made in writing and included in the same envelope with the bid.

8. BID DEPOSITS.

Bid deposits are to be made payable to the City of Waltham. In the event that the successful bidder fails to execute a Contract within (10) days of the receipt of said contract, such security shall be retained by the city as liquidated damages. Unsuccessful bidders' deposits will be returned immediately following the award to said successful bidder.

9. WITHDRAW.

A Bid may be withdrawn by written request prior to the schedule for the Bid Opening. No withdrawals are permitted after the bid opening date and time. Withdrawals after the bid opening date will cause the forfeit of the bid Deposit.

10. AWARD.

Bids will be awarded not later than (90) ninety days after the scheduled bid opening date, unless otherwise stated, in the specifications. Unless otherwise specified, bids will be evaluated on the basis of, completeness of your RFP response, responsiveness, responsibility, best price and experience.

11. AWARD CRITERIA.

Qualified and responsive proposals will be evaluated based on Price, Technical, and Compliance requirements:

12. DISCOUNTS.

Discounts for prompt payments will be considered when making awards.

13. TAX EXEMPT.

Purchases by the City of Waltham is exempt from any Federal, State or Massachusetts Municipal Sales and/or Excise Taxes.

14. SAMPLES.

The City of Waltham may require the submission of samples either before or after the awarding of a contract. Samples are to be submitted, at no charge to the City, so as to ascertain the product's suitability.

If specifically stated in the Bid that samples are required, said samples must be submitted with the Bid prior to the Official Bid Opening. Failure to submit said samples would be cause for rejection of Bid. All samples must be called for and picked up within (30) thirty days of award or said samples will be presumed abandoned and will be disposed of.

15. ACTIVE VENDOR LIST.

Vendors who wish to remain on the Active Bid List must either submit a Bid, No Bid, or a letter requesting same, no later than the Official Bid Opening. This is applicable to those vendors who have received the Invitation to Bid.

16. FUNDS APPROPRIATION.

THE CONTRACT OBLIGATION ON BEHALF OF THE CITY IS SUBJECT TO PRIOR APPROPRIATION OF MONIES FROM THE GOVERNMENTAL BODY AND AUTHORIZATION BY THE MAYOR.

17. THE AWARDING AUTHORITY RESERVES THE RIGHT TO REJECT ANY OR ALL BIDS, OR ANY PART OF ANY BID, WHICH IN THE OPINION OF THE AWARDING AUTHORITY, IS IN THE BEST INTERESTS OF THE CITY OF WALTHAM.

18. THE TAX ATTESTATION CLAUSE, CERTIFICATION OF NON-COLLUSION AND THE CERTIFICATE OF VOTE AUTHORIZATION, are required by statute and are an integral part of the Invitation for Bid and must be completed and signed by the person submitting the Bid, or by the person/persons who are officially authorized to do so. Failure to do so may disqualify the bid.

19. STANDARD OF QUALITY.

Where, in the specifications, one certain kind, type, catalog number, brand or manufacturer of material is named, it shall be regarded as the required standard of quality. Where two or more are named, these are presumed to be equal and the Bidder may select one or the other.

If the Bidder proposes to offer a substitute as an equal, he shall so indicate on the Bid Form, the kind, type, catalog number, brand, or manufacturer of material that is offered as an equal, and describe where it differs from the specifications. Substituted items must be capable of performing all the functions and/or operational features described or indicated in the specifications. Failure to indicate the description of any substitute item on the Bid will be interpreted to mean that the Bidder will furnish the item or service as specified.

20. MODIFICATION.

No agreement, understanding, alteration or variation of the agreement, terms or provisions herein contained shall bind the parties, hereto unless made and executed in writing by the parties hereto.

21. ASSIGNMENT.

The final payment for work done under this Contract shall be made only after the Contractor has signed a statement under the penalty of perjury, certifying that he has completed the work described in the final estimate. Neither party hereto shall assign this Contract or sublet it in part or as a whole without the prior written consent of the other party hereto. The Contractor shall not assign any sum or sums due or becoming due to him hereunder without the prior written consent of the City.

22. DELIVERIES:

a) The Contractor shall pay all freight and delivery charges. The Waltham Purchasing Department does not pay for shipping and packaging expenses. Items must be delivered as stipulated in the specifications. All deliveries must be made to the inside of city buildings. Sidewalk deliveries will not be accepted. City personnel are not required to assist in the deliveries and contractors are cautioned to notify their shippers that adequate assistance must be provided at the point of delivery, when necessary.

b) All items of furniture must be delivered inside the building, set up, in place and ready for use. Deliveries are to be made between the hours of 8:30 a.m. and 3:00 p.m., Monday through Friday, except on holidays.

c) All damaged items, or items which do not comply with specifications will not be accepted and title therefore will not vest to the Waltham Purchasing Department until such items are accepted and signed for, in good order, by the receiving department.

d) The contractor must replace, without further cost to the Waltham Purchasing Department, such damaged or non-complying items before payment will be made.

23. LABELING.

All packages cartons or other containers must be clearly marked with (a) building and room destination; (b) description of contents of item number from specifications; (c) quantity; (d) City of Waltham Purchase Order Number and (e) Vendor's name and order number.

24. GUARANTEES.

Unless otherwise stipulated in the specifications, furniture, equipment and similar durable items shall be guaranteed by the contractor for a period of not less than one year from the date of delivery and acceptance by the receiving department. In addition, the manufacturer's guarantee shall be furnished. Any items provided under this contract which are or become defective during the guarantee period shall be replaced the contractor free of charge with the specific understanding that all replacements shall carry the same guarantee as the original equipment. The contractor shall make such replacement immediately upon receiving notice from the Purchasing Agent.

25. SINGLE VENDOR.

The Waltham Purchasing Department desires to award a single contract based on the Grand Total Price. However, where applicable, the City reserves the right to make multiple awards on a unit price basis if, in the opinion of the Waltham Purchasing Department, it is in the best interest of the Waltham Purchasing Department.

26. CHANGE ORDERS.

Change orders are not effective until, if, as and when signed by the Mayor and no work is to commence until the change orders are fully executed.

28. BID OPENING INCLEMENT WEATHER

If, at the time of the originally scheduled bid opening, City Hall is closed to inclement weather or another unforeseeable event, the bid opening will be extended until 2:00 PM on the next normal business day. Bids will be accepted until that date and time.

SECTION 00301

BID FORM

To the City of Waltham, Massachusetts, acting through its Mayor:

The Undersigned, as Bidder, declares as follows:

- The only parties interested in this BID as Principals are named herein;
- this BID is made without collusion with any other person, firm, or corporation;
- no officer, agent, or employee of the Owner is directly or indirectly interested in this BID;
- the Bidder has carefully examined the site of the proposed Work and fully informed and satisfied himself as to the conditions there existing, the character and requirements of the proposed Work, the difficulties attendant upon its execution and the accuracy of all estimated quantities stated in this BID, and has carefully read and examined the Drawings, the annexed proposed AGREEMENT and the Specifications and other Contract Documents therein referred to and knows and understands the terms and provisions thereof;
- understands that information relative to subsurface and other conditions, natural phenomena, existing pipes and other structures (surface and/or subsurface) has been furnished only for his information and convenience without any warranty or guarantee, expressed or implied, that the subsurface and/or other conditions, natural phenomena, existing pipes and other structures (surface and/or subsurface) actually encountered will be the same as those shown on the Drawings or in any of the other Contract Documents and agrees that the Bidder shall not use or be entitled to use any such information made available to him through the Contract Documents or otherwise or obtained by him in his own examination of the site, as a basis of or ground for any claim against the Owner or the Engineer arising from or by reason of any variance which may exist between the aforesaid information made available to or acquired by him and the subsurface and/or other conditions, natural phenomena, existing pipes and other structures (surface and/or subsurface) actually encountered during the construction work, and has made due allowance therefore in this BID;
- and the Bidder understands that the quantities of work tabulated in this BID or indicated on the Drawings or in the Specifications or other Contract Documents are only approximate and are subject to increase or decrease as deemed necessary by the Engineer;
- and agrees that, if this is accepted will contract with the Owner, as provided the copy of the Contract Documents deposited in the office of the Engineer, this BID form being part of said Documents, that the will perform all work and all the materials and equipment, and provide all labor, services, plant, machinery, apparatus, appliances, tools, supplies all other required by Contract Documents the manner within the therein prescribed according to the requirements the

Engineer as therein set forth, and that the Bidder will take in full payment therefore the lump sum or unit price applicable to each item of the Work as stated in the following schedule:

BID FORM  
00301-1

Bidders must bid on each item of the Base Bid. All entries in the entire BID must be made clearly and in ink; prices bid must be written in both words and figures. In case of discrepancy, the amount shown in words will govern.

Bidders shall insert extended item prices obtained from quantities and unit prices. In case of discrepancy between the product obtained by multiplying the estimated quantity by the unit price, the actual product shall apply. In case of discrepancy between the sum of the total figure of the items and the total amount listed, the actual sum shall apply.

Receipt of Addenda numbered \_\_\_\_\_ to \_\_\_\_\_ , inclusive, is acknowledged.

(Bidder) \_\_\_\_\_

(by) \_\_\_\_\_

(Title) \_\_\_\_\_

**BASE BID**

**Sump Pump Amnesty Program - Contract 2**

Refer to Section 01024 - Measurement and Payment for Item Descriptions. The work of the General Bidder, being all work covered by items 1 through 9, inclusive.

Item No.	Item Description Unit Price in Words	Units	Estimated Quantity	Unit Price (In Figures)	Extended Amount (In Figures)
1	Mobilization and Demobilization _____ Dollars and Cents	LS	1		
2	Installing new On-Site Infiltration System, Private Inflow Removal and Sump Pump Discharge Redirection to the new On-Site Infiltration System _____ Dollars and Cents	ea.	17		
3	Private Inflow Removal and Sump Pump Discharge Redirection and Connection to the Existing Drainage System				
3.1	74 Amherst Avenue _____ Dollars and Cents	LS	1		
3.2	46 College Farm Road _____ Dollars and Cents	LS	1		
3.3	63 Indian Road _____ Dollars and Cents	LS	1		
3.4	86 Indian Road _____ Dollars and Cents	LS	1		
3.5	89 Indian Road _____ Dollars and Cents	LS	1		
3.6	78 Lake Street _____ Dollars and Cents	LS	1		
3.7	103 Lake Street _____ Dollars and Cents	LS	1		
3.8	120 Lake Street _____ Dollars and Cents	LS	1		
3.9	126 Lake Street _____ Dollars and Cents	LS	1		
3.10	133 Lake Street _____ Dollars and Cents	LS	1		

**BID FORM  
00301-3**



3.11	48 Lakeview Terrace				
	_____ Dollars and _____ Cents	LS	1		
3.12	52 Lakeview Terrace				
	_____ Dollars and _____ Cents	LS	1		
3.13	53 Lakeview Terrace				
	_____ Dollars and _____ Cents	LS	1		
3.14	59 Lakeview Terrace				
	_____ Dollars and _____ Cents	LS	1		
3.15	60 Lakeview Terrace				
	_____ Dollars and _____ Cents	LS	1		
3.16	598 Lexington Street				
	_____ Dollars and _____ Cents	LS	1		
3.17	107 Mokema Avenue				
	_____ Dollars and _____ Cents	LS	1		
3.18	50 Mount Walley Road				
	_____ Dollars and _____ Cents	LS	1		
3.19	98 Princeton Avenue				
	_____ Dollars and _____ Cents	LS	1		
3.20	104 Princeton Avenue				
	_____ Dollars and _____ Cents	LS	1		
3.21	105 Princeton Avenue				
	_____ Dollars and _____ Cents	LS	1		
3.22	33 Seminole Avenue				
	_____ Dollars and _____ Cents	LS	1		
3.23	49 Seminole Avenue				
	_____ Dollars and _____ Cents	LS	1		
3.24	26 Shore Road				
	_____ Dollars and _____ Cents	LS	1		
3.25	6 Wampum Avenue				
	_____ Dollars and _____ Cents	LS	1		
3.26	8 Wampum Avenue				
	_____ Dollars and _____ Cents	LS	1		
3.27	100 Longfellow Road				
	_____ Dollars and _____ Cents	LS	1		
3.28	26 Bruce Road				
	_____ Dollars and _____ Cents	LS	1		

**BID FORM  
00301-4**

Sump Pump Amnesty Program  
Contract 2- Areas 5B, 5D and 15  
Waltham, Massachusetts

3.29	71 Stone Road _____ Dollars and Cents	LS	1		
3.30	4 Allen Road _____ Dollars and Cents	LS	1		
3.31	78 Whitman Road _____ Dollars and Cents	LS	1		
3.32	25 Hagar Lane _____ Dollars and Cents	LS	1		
3.33	84 Whitman Road _____ Dollars and Cents	LS	1		
3.34	19 Hagar Lane _____ Dollars and Cents	LS	1		
3.35	61 Stone Road _____ Dollars and Cents	LS	1		
3.36	160 Longfellow Road _____ Dollars and Cents	LS	1		
4	Private Inflow Removal and Sump Pump Discharge Redirection and Connection to the New Storm Drain _____ Dollars and Cents	ea.	3		
5	New Storm Drain Piping (12" RCP), and Appurtenances _____ Dollars and Cents	lf	163		
6	Environmental Protection and Controls _____ Dollars and Cents	LS	1		
7	Rock Excavation and Disposal _____ Dollars and Cents	cy	50		
8	All Other Work/Remaining Lump Sum Items _____ Dollars and Cents	LS	1		
9	Police Detail Allowance _____ Dollars and Cents	hr	300	\$50/hr	\$15,000
10	Cut and Splash Roof Leaders Allowance _____ Dollars and Cents	ea.	10		

BID FORM  
00301-5

TOTAL FOR BASE BID

Total Amount of Base Bid (**Basis of Award**) (Items 1 through 10 inclusive).

\$ \_\_\_\_\_  
(Amount in figures)

\_\_\_\_\_  
(Amount in words)

The bidder understands that the Owner reserves the right to reject any and all bids and to waive any informality in the bidding.

The undersigned agrees that for extra work, if any, will be performed in accordance with Article 10 of the General Conditions of the Contract and will be paid for in accordance with Article 11 of the General Conditions of the Contract.

The bid security accompanying this BID shall be in the amount of 5 percent of the BID payable to the City of Waltham.

**The time for completion of this contract is 150 calendar days From the Date of the Notice to Proceed (NTP) and excluding final paving.** Liquidated damages specified in this contract are \$1,000 per day for each calendar day beyond the contract completion date that work remains uncompleted.

Bids shall be valid for ninety (90) days and cannot be withdrawn until after the 90-day period has expired.

The undersigned agrees that if the Owner accepts this BID, the bidder will duly execute and acknowledge the AGREEMENT and furnish, duly executed and acknowledged, the required CONTRACT BONDS within ten (10) days, Saturdays, Sundays, and legal holidays excluded, after notification that the AGREEMENT and other Contract Documents are ready for signature.

A performance bond in an amount equal to 100 percent of the total amount of the bid with a surety company qualified to do business in the Commonwealth of Massachusetts will be required for the faithful performance of the contract, as well as a labor and materials bond in an amount equal to 100 percent of the total bid amount.

Should the bidder fail to fulfill any of his agreements as hereinabove set forth, the Owner shall have the right to retain as liquidated damages the amount of the bid check or cash which shall become the Owner's property. If a bid bond was given, it is agreed that the amount thereof shall be paid as liquidated damages to the Owner by the Surety.

The bidder, by submittal of this BID, agrees with the Owner that the amount of the bid security deposited with this BID fairly and reasonably represents the amount of damages the Owner will suffer due to the failure of the bidder to fulfill his agreements as above provided.

The undersigned bidder hereby certifies he/she will comply with the minority workforce percentage ratio and specific affirmative action steps contained in the EEO/AA provisions of this Contract, including compliance with the Minority/Woman Business Enterprise as required under these contract provisions. The Contractor receiving the award of the contract shall be required to obtain from each of its subcontractors a copy of the certification by said subcontractor, regardless of tier, that it will comply with the minority workforce ratio and specific affirmative action steps contained in these

BID FORM  
00301-6

contract provisions and submit it to the contracting agency prior to the award of such subcontract.

The undersigned further certifies under penalty of perjury that the said undersigned is not presently debarred from doing public construction work in the Commonwealth under the provisions of Section Twenty-Nine F of Chapter Twenty-Nine, or any other applicable debarment provisions of any other chapter of the General Laws or any rule or regulation promulgated thereunder.

Pursuant to M.G.L. Ch. 62C, sec. 49A, I certify under the penalties of perjury that I, to my best knowledge and belief, have filed all state tax returns and paid all state taxes required under law.

The undersigned hereby certifies that he is able to furnish labor that can work in harmony with all other elements of labor employed or to be employed on the work and that he will comply fully with all laws and regulations applicable to awards made subject to MOL Ch. 30, Section 39M. The bidding and award of the contract will be in full compliance with Section 39M inclusive of Chapter 30 of the General Laws of the Commonwealth of Massachusetts as last revised.

The undersigned certifies under penalties of perjury that this bid is in all respects bona fide, fair and made without collusion or fraud with any other person. As used in this paragraph the word "person" shall mean any natural person, joint venture, partnership, corporation or other business or legal entity. The attached CERTIFICATE OF NON-COLLUSION must be signed and submitted as part of the Bid Proposal.

\_\_\_\_\_  
(Name of General Bidder)

By \_\_\_\_\_  
(Signature and title of authorized representative)

Date \_\_\_\_\_

SEAL

\_\_\_\_\_  
(Telephone)

\_\_\_\_\_  
(Business address)

\_\_\_\_\_  
(Fax Number)

\_\_\_\_\_  
(City, State, Zip)

BID FORM  
00301-7

The following documents are attached to and made a condition of the bid, and shall be filed with the bid:

- Bid Security (5%)
- Completed and signed Bid Proposal (Section 00301)
- Contractor's Certification (Attached to Section 00301)
- Massachusetts Diesel Retrofit Program Statement (Attached to Section 00301)
- Completed Certificate of Non-Collusion (Section 00480)
- Completed Certificate of Corporate Vote (Corporation Only) (Section 00481)
- Completed Certificate as to Payment of State Taxes (Section 00482)
- Completed State "Debarment Disclosure Form for Public Contracts" (Section 00484)

The Bidder is requested to list four or more of your firm's recent projects of a similar character as required for acceptable bid. References will enable the Owner to judge his experience, skill, and business standing.

Project Name: _____
Project Location: _____
Contract Amount: \$ _____ Completion Date _____
Owner: _____
Contact Name: _____ Telephone: _____
Architect/Engineer: _____
Contact Name: _____ Telephone: _____

Project Name: _____
Project Location: _____
Contract Amount: \$ _____ Completion Date _____
Owner: _____
Contact Name: _____ Telephone: _____
Architect/Engineer: _____
Contact Name: _____ Telephone: _____

Project Name: \_\_\_\_\_  
Project Location: \_\_\_\_\_  
Contract Amount: \$ \_\_\_\_\_ Completion Date \_\_\_\_\_  
Owner: \_\_\_\_\_  
Contact Name: \_\_\_\_\_ Telephone: \_\_\_\_\_  
Architect/Engineer: \_\_\_\_\_  
Contact Name: \_\_\_\_\_ Telephone: \_\_\_\_\_

Project Name: \_\_\_\_\_  
Project Location: \_\_\_\_\_  
Contract Amount: \$ \_\_\_\_\_ Completion Date \_\_\_\_\_  
Owner: \_\_\_\_\_  
Contact Name: \_\_\_\_\_ Telephone: \_\_\_\_\_  
Architect/Engineer: \_\_\_\_\_  
Contact Name: \_\_\_\_\_ Telephone: \_\_\_\_\_

Add supplementary page if necessary.

END OF SECTION 00301

**COMPLIANCE FORMS**

**(PLEASE COMPLETE AND SUBMIT THESE FORMS WITH YOUR RESPONSE)**



SECTION 00480

**NON-COLLUSION FORM AND TAX COMPLIANCE FORM**

**CERTIFICATE OF NON-COLLUSION**

The undersigned certifies under penalties of perjury that this bid or proposal has been made and submitted in good faith and without collusion or fraud with any other person. As used in this certification, the word “person” shall mean any natural person, business, partnership, corporation, union, committee, club, or other organization, entity or group of individuals. The undersigned certifies that no representations made by any City officials, employees, entity, or group of individuals other than the Purchasing Agent of the City of Waltham was relied upon in the making of this bid

\_\_\_\_\_, \_\_\_\_\_  
(Signature of person signing bid or proposal)                      Date

\_\_\_\_\_  
(Name of business)

SECTION 00481

**CERTIFICATE OF VOTE OF AUTHORIZATION**

Date:

I \_\_\_\_\_, Clerk of \_\_\_\_\_ hereby certify that at a meeting of the Board of Directors of said Corporation duly held on the \_\_\_\_\_ day of \_\_\_\_\_ at which time a quorum was present and voting throughout, the following vote was duly passed and is now in full force and effect:

VOTED: That \_\_\_\_\_ (*name*) is hereby authorized, directed and empowered for the name and on behalf of this Corporation to sign, seal with the corporate seal, execute, acknowledge and deliver all contracts and other obligations of this Corporation; the execution of any such contract to be valid and binding upon this Corporation for all purposes, and that this vote shall remain in full force and effect unless and until the same has been altered, amended or revoked by a subsequent vote of such directors and a certificate of such later vote attested by the Clerk of this Corporation.

I further certify that \_\_\_\_\_ is duly elected/appointed \_\_\_\_\_ of said corporation

SIGNED:

(Corporate Seal)

\_\_\_\_\_  
Clerk of the Corporation:

Print Name: \_\_\_\_\_

---

COMMONWEALTH OF MASSACHUSETTS

County of \_\_\_\_\_

Date:

Then personally appeared the above named and acknowledged the foregoing instrument to be their free act and deed before me, \_\_\_\_\_

Notary Public;

My Commission expires: \_\_\_\_\_

SECTION 00482

**TAX COMPLIANCE CERTIFICATION**

Pursuant to M.G.L. c. 62C, & 49A, I certify under the penalties of perjury that, to the best of my knowledge and belief, I am in compliance with all laws of the Commonwealth relating to taxes, reporting of employees and contractors, and withholding and remitting child support.

\_\_\_\_\_, \_\_\_\_\_  
Signature of person submitting bid or proposal                      Date

\_\_\_\_\_  
Name of business

**NOTE**

Failure to submit any of the required documents, in this or in other sections, with your bid response package may cause the disqualification of your proposal.

SECTION 00483

**CORPORATION IDENTIFICATION**

The bidder for the information of the Awarding Authority furnishes the following information.

If a Corporation:

Incorporated in what state \_\_\_\_\_

President \_\_\_\_\_

Treasurer \_\_\_\_\_

Secretary \_\_\_\_\_

Federal ID Number \_\_\_\_\_

If a foreign (out of State) Corporation – Are you registered to do business in Massachusetts?

Yes \_\_\_\_\_, No \_\_\_\_\_

If you are selected for this work you are required under M.G.L.ch. 30S, 39L to obtain from the Secretary of State, Foreign Corp. Section, State House, Boston, a certificate stating that you Corporation is registered, and furnish said certificate to the Awarding Authority prior to the award.

If a Partnership: (Name all partners)

Name of partner \_\_\_\_\_

Residence \_\_\_\_\_

Name of partner \_\_\_\_\_

Residence \_\_\_\_\_

If an Individual:

Name \_\_\_\_\_

Residence \_\_\_\_\_

If an Individual doing business under a firm's name:

Name of Firm \_\_\_\_\_

Name of Individual \_\_\_\_\_

Business Address \_\_\_\_\_

Residence \_\_\_\_\_

Date \_\_\_\_\_

Name of Bidder \_\_\_\_\_

By \_\_\_\_\_

Signature \_\_\_\_\_

Title \_\_\_\_\_

Business Address \_\_\_\_\_ (POST OFFICE BOX NUMBER NOT ACCEPTABLE)

City \_\_\_\_\_ State \_\_\_\_\_ Telephone Number \_\_\_\_\_ Today's Date \_\_\_\_\_

SECTION 00484

**DEBARMENT CERTIFICATION**

In connection with this bid and all procurement transactions, by signature thereon, the respondent certifies that neither the company nor its principals are suspended, debarred, proposed for debarment, declared ineligible, or voluntarily excluded from the award of contracts, procurement or non procurement programs from the Commonwealth of Massachusetts, the US Federal Government and /or the City of Waltham. "Principals" means officers, directors, owners, partners and persons having primary interest, management or supervisory responsibilities with the business entity. Vendors shall provide immediate written notification to the Purchasing Agent of the City of Waltham at any time during the period of the contract of prior to the contract award if the vendor learns of any changed condition with regards to the debarment of the company or its officers. This certification is a material representation of fact upon which reliance will be placed when making the business award. If at any time it is determined that the vendor knowingly misrepresented this certification, in addition to other legal remedies available to the City of Waltham, the contract will be cancelled and the award revoked.

---

Company Name \_\_\_\_\_

Address \_\_\_\_\_

City \_\_\_\_\_, State \_\_\_\_\_, Zip Code \_\_\_\_\_

Phone Number (\_\_\_\_) \_\_\_\_\_

E-Mail Address \_\_\_\_\_

Signed by Authorized Company Representative: \_\_\_\_\_

Print Name \_\_\_\_\_, Date \_\_\_\_\_

**WEEKLY PAYROLL RECORDS REPORT  
& STATEMENT OF COMPLIANCE**

In accordance with Massachusetts General Law c. 149, §27B, a true and accurate record must be kept of all persons employed on the public works project for which the enclosed rates have been provided, A Payroll Form has been printed on the reverse of this page and includes all the information required to be kept by law. Every contractor or subcontractor is required to keep these records and preserve them for a period of three years from the date of completion of the contract. In addition, every contractor and subcontractor is required to submit, on a weekly basis, a copy of his or her weekly payroll records to the awarding authority. For every week in which an apprentice is employed, a photocopy of the apprentice's identification card must be attached to the payroll report. Once collected, the awarding authority is also required to preserve those reports for three years. In addition, each such contractor, subcontractor, or public body shall furnish to the awarding authority directly, within fifteen days after completion of its portion of the work, a statement, executed by the contractor, subcontractor or public body who supervises the payment of wages, in the following form:

**STATEMENT OF COMPLIANCE**

\_\_\_\_\_, 201\_\_

I \_\_\_\_\_,  
(Name of signatory party) \_\_\_\_\_ (Title)

I do hereby state that I pay or supervise the payment of the persons employed by  
\_\_\_\_\_ On the \_\_\_\_\_  
(Contractor, subcontractor or public body) (Building or project)

and that all mechanics and apprentices, teamsters, chauffeurs and laborers employed on said project have been paid in accordance with wages determined under the provisions of sections twenty-six and twenty-seven of chapter one hundred and forty nine of the General Laws.

Signature \_\_\_\_\_, Title \_\_\_\_\_

Print \_\_\_\_\_, Date \_\_\_\_\_

**WEEKLY PAYROLL REPORT FORM**

Company Name: \_\_\_\_\_  
 Prime Contractor

Project Name: \_\_\_\_\_  
 Subcontractor  
 List Prime Contractor: \_\_\_\_\_

Awarding Auth.: \_\_\_\_\_  
 Employer Signature: \_\_\_\_\_

Work Week Ending: \_\_\_\_\_  
 Print Name & Title: \_\_\_\_\_

Final Report

Employee Name & Address	Work Classification	(A) Hours Worked							(B) Hourly Base Wage	(C) Employer Contributions			(F) [B+C+D+E] Hourly Total Wage (prev. wage)	(G) [A*F] Weekly Total Amount	
		(A) Tot. Hrs.								(C) Health & Welfare	(D) Pension	(E) Supp. Unemp.			
		S	M	T	W	T	F	S							

NOTE: Every contractor and subcontractor is required to submit a copy of their weekly payroll records to the awarding authority.

SECTION 00486

**10 HOURS OSHA TRAINING CONFIRMATION**

**Chapter 306 of the Acts of 2004**

**CONSTRUCTION PROJECTS**

**AN ACT RELATIVE TO THE HEALTH AND SAFETY ON PUBLIC**

The undersigned hereby certifies that all employees to be employed at a worksite for construction, reconstruction, alteration, remodeling, repair, installation, demolition, maintenance or repair of any public work or any public building estimated to cost more than \$10,000.00 have successfully completed a course in construction safety and health approved by the United States Occupational Safety and Health Administration that is at least 10 hours in duration at the time the employee begins work and who shall furnish documentation of successful completion of said course with the first payroll report for each employee and will comply with all laws and regulations applicable to awards of subcontracts subject to section 44F.

Company Name: \_\_\_\_\_

Address: \_\_\_\_\_

Signature: \_\_\_\_\_

Title: \_\_\_\_\_

Print Name \_\_\_\_\_

Date \_\_\_\_\_

*See following Chapter 306 of the Acts of 2004*

**NOTE**

Failure to submit any of the required documents, in this or in other sections, with your bid response package will be cause for the disqualification of your company.



**Section 00500**

**AGREEMENT**

**CITY OF WALTHAM**

**ARTICLE 1.** This agreement, made this \_\_\_\_\_ day of \_\_\_\_\_, 2013 by and between the CITY OF WALTHAM, party of the first part, hereinafter called the CITY, by its MAYOR, and

---

hereinafter called the CONTRACTOR.

**ARTICLE 2.** Witnesseth, that the parties to this agreement, each in consideration of the agreement on the part of the others herein contained, do hereby agree, the CITY OF WALTHAM for itself, and said contractor for his heirs, executors, administrators and assigns as follows:

To furnish all equipment, machinery, tools and labor, to furnish and deliver all materials required to be furnished (except as otherwise specified) and deliver in and about the project and to do and perform all work in strict conformity with the provisions of this Contract and of the Notice to Bidders, bid, Project Manual, and Drawings hereto annexed. The said Notice to Bidders, bid, Project Manual, and Drawings are hereby made a part of this contract as fully and to the same effect as if the same had been set forth at length and incorporated in the contracts.

**ARTICLE 3.** In consideration of the foregoing premises the CITY agrees to pay and the CONTRACTOR agrees to receive as full compensation for everything furnished and done by the CONTRACTOR under this contract, including all work required by not included in the items herein mentioned, and also for all loss or damage arising out of the nature of the work aforesaid, or from the action of the elements, or from any unforeseen obstruction or difficulty encountered in the prosecution of the work, and for all expenses incurred by or in consequence of the suspension or discontinuance of the work specified, and for well and faithfully completing the work, and the whole thereof, as herein provided, such prices as are set forth in the accompanying bid.

This Agreement entered into as of the day and year first written above.

**CITY OF WALTHAM, MASSACHUSETTS**

**FOR THE CITY**

\_\_\_\_\_  
Jeannette A. McCarthy, MAYOR,  
City of Waltham  
Date: \_\_\_\_\_

\_\_\_\_\_  
John B. Cervone, City Solicitor  
Date: \_\_\_\_\_  
APPROVED AS TO FORM ONLY

\_\_\_\_\_  
Stephen Casazza, City Engineer  
Date: \_\_\_\_\_

\_\_\_\_\_  
Joseph Pedulla, Purchasing Agent  
Date: \_\_\_\_\_

\_\_\_\_\_  
Paul Centofanti, Auditor  
Date: \_\_\_\_\_

I CERTIFY THAT SUFFICIENT FUNDS  
ARE AVAILABLE FOR THIS CONTRACT

**FOR THE COMPANY**

\_\_\_\_\_  
CONTRACTOR (Signature),  
Date: \_\_\_\_\_

\_\_\_\_\_  
Company

\_\_\_\_\_  
Address

**SECTION 00610**

**PERFORMANCE BOND**

CITY OF WALTHAM

KNOW ALL MEN BY THESE PRESENT THAT,

\_\_\_\_\_ as

principal and \_\_\_\_\_ as surety, are held and firmly bound unto the CITY OF WALTHAM and to such persons, firms, and corporations, who may furnish materials for or perform labor on the work, construction or improvements contemplated in the Contract hereinafter mentioned, or who may have any suits or claims for injury or damage to persons or property resulting from or arising out of the work done under this Contract, in the

SUM OF \_\_\_\_\_ DOLLARS (\$ \_\_\_\_\_)

(lawful money of the United States of America) for the payment whereof the Contractor and the Surety of Sureties bind themselves and their heirs, executors, administrators, successors and assigns, jointly and severally, firmly by these presents.

THE CONDITION OF THIS OBLIGATION IS SUCH, THAT for the above burden (the Contractor) its

\_\_\_\_\_  
heirs, executors, administrators and assigns, shall faithfully perform the Contract, on his part and during the life of any guaranty or warranty, for defective materials and workmanship required under this Contract, and satisfy all claims and demands incurred for the same; and shall fully indemnify and save harmless the City from all cost and damage which it may suffer by reason of failure so to do, and shall fully reimburse and repay the City all outlay and expense which the City may incur in making good any such default, and shall promptly make payment to all persons supplying labor or materials for use in the prosecution of the work provided for in said Contract; and shall indemnify and save harmless the said City, its officers and agents from any and all suits or claims for injury or damage to persons or property resulting from or arising out of the work done under this Contract, then this obligation shall be null and void; otherwise it shall remain in full force and effect.

PROVIDED, HOWEVER, that (except as to the City) no suit, action or proceeding by reason of any default whatever shall be brought on this Bond after two years from the day on which the final payment under the Contract falls due.

AND PROVIDED, that any alterations which may be made in the terms of the Contract or in the work to be done under it, or any assignment, transfer or subletting of any part of the work, or the giving by the City of any extension of time for the performance of the Contract, or any other forbearance on the part of either the City or the Contractor to the other, shall not in any way release the Contractor and the Surety of Sureties, or either or any of them, their heirs, executors, administrators, successors or assigns from their liability hereunder, notice to the Surety or Sureties of any such alterations, assignment, transfer, subletting extension or forbearance being hereby waived.

This Bond is made for the use and benefit of all persons, firms, and corporations who may furnish materials, or perform any labor for or on account of said work, construction or improvements, or who may have any suits or claims for injury or damage to persons or property resulting from or arising out of the work done under this Contract, and they and each of them are hereby made obligees hereunder the same as if their own proper names were written herein as such, and they and each of them may sue hereon in their own names for their own use and benefit.

And the Surety, for value received, hereby stipulates and agrees that no change, extension of time, alteration or addition to the terms of the Contract or to the work to be performed hereunder, or the Specifications accompanying the same, shall in any way affect its obligations on this Bond, and it does hereby waive notice of any such changes, extension of time, alteration or addition to the terms of the Contract or to the work, or to the Specifications.

IN WITNESS WHEREOF, said Contractor and Surety have hereunto set their respective names this \_\_\_\_ day of \_\_\_\_\_, 20\_\_\_\_\_.

WITNESSES:

(CONTRACTOR) (SEAL)

NAME \_\_\_\_\_ BY \_\_\_\_\_  
(SIGNATURE AND TITLE)

ADDRESS \_\_\_\_\_  
(SURETY) (SEAL)

NAME \_\_\_\_\_ BY \_\_\_\_\_  
(SIGNATURE AND TITLE)

ADDRESS \_\_\_\_\_ BY \_\_\_\_\_  
(ATTORNEY-IN-FACT)

POWER OF ATTORNEY

Attorneys-in-fact who sign bonds must file with each bond a certified copy of their power of attorney to sign said bonds.

**SECTION 00620**

**PAYMENT BOND**

**CITY OF WALTHAM**

KNOW ALL MEN BY THESE PRESENT THAT,

\_\_\_\_\_ as

principal and \_\_\_\_\_ as surety, are held and firmly bound unto the CITY OF WALTHAM and to such persons, firms, and corporations, who may furnish materials for or perform labor on the work, construction or improvements contemplated in the Contract hereinafter mentioned, or who may have any suits or claims for injury or damage to persons or property resulting from or arising out of the work done under this Contract, in the

SUM OF \_\_\_\_\_ DOLLARS (\$ \_\_\_\_\_) (lawful money of the United States of America) for the payment whereof the Contractor and the Surety of Sureties bind themselves and their heirs, executors, administrators, successors and assigns, jointly and severally, firmly by these presents.

THE CONDITION OF THIS OBLIGATION IS SUCH, THAT for the above burden (the Contractor) its

\_\_\_\_\_ heirs, executors, administrators and assigns, shall faithfully perform the Contract, on his part and during the life of any guaranty or warranty, for defective materials and workmanship required under this Contract, and satisfy all claims and demands incurred for the same; and shall fully indemnify and save harmless the City from all cost and damage which it may suffer by reason of failure so to do, and shall fully reimburse and repay the City all outlay and expense which the City may incur in making good any such default, and shall promptly make payment to all persons supplying labor or materials for use in the prosecution of the work provided for in said Contract; and shall indemnify and save harmless the said City, its officers and agents from any and all suits or claims for injury or damage to persons or property resulting from or arising our of the work done under this Contract, then this obligation shall be null and void; otherwise it shall remain in full force and effect.

PROVIDED, HOWEVER, that (except as to the City) no suit, action or proceeding by reason of any default whatever shall be brought on this Bond after two years from the day on which the final payment under the Contract falls due.

AND PROVIDED, that any alterations which may be made in the terms of the Contract or in the work to be done under it, or any assignment, transfer or subletting of any part of the work, or the giving by the City of any extension of time for the payment of the Contract, or any other forbearance on the part of either the City or the Contractor to the other, shall not in any way release the Contractor and the Surety of Sureties, or either or any of them, their heirs, executors, administrators, successors or assigns from their liability hereunder, notice to the Surety or Sureties of any such alterations, assignment, transfer, subletting extension or forbearance being hereby waived.

This Bond is made for the use and benefit of all persons, firms, and corporations who may furnish materials, or perform any labor for or on account of said work, construction or improvements, or who may have any suits or claims for injury or damage to persons or property resulting from or arising out of the work done under this Contract, and they and each of them are hereby made obligees hereunder the same as if their own proper names were written herein as such, and they and each of them may sue hereon in their own names for their own use and benefit.

And the Surety, for value received, hereby stipulates and agrees that no change, extension of time, alteration or addition to the terms of the Contract or to the work to be performed hereunder, or the Specifications accompanying the same, shall in any way affect its obligations on this Bond, and it does hereby waive notice of any such changes, extension of time, alteration or addition to the terms of the Contract or to the work, or to the Specifications.

IN WITNESS WHEREOF, said Contractor and Surety have hereunto set their respective names this \_\_\_\_\_ day of \_\_\_\_\_, 20\_\_\_\_\_.

WITNESSES:

(CONTRACTOR) (SEAL)

NAME \_\_\_\_\_ BY \_\_\_\_\_  
(SIGNATURE AND TITLE)

ADDRESS \_\_\_\_\_  
(SURETY) (SEAL)

NAME \_\_\_\_\_ BY \_\_\_\_\_  
(SIGNATURE AND TITLE)

ADDRESS \_\_\_\_\_ BY \_\_\_\_\_  
(ATTORNEY-IN-FACT)

POWER OF ATTORNEY

Attorneys-in-fact who sign bonds must file with each bond a certified copy of their power of attorney to sign said bonds.

**Section 00700**

# **GENERAL CONDITIONS**

## GENERAL CONDITIONS

1. INFORMATION

All information shall come from the Office of the City Purchasing Agent. The Contractor shall inquire at this office for any information needed. Wherever the words “or equal as approved” are used, it is to be understood that the opinion of the City Purchasing Agent shall govern.

2. SUITS

The Contractor shall assume defense of and shall indemnify and hold the City and its agents harmless from all suits and claims against the City and its sub-contractors arising from the use of any invention, patent right labor or employment, or from any act of omission or neglect of the City, its agents, employees or any subcontractor in performing the work, under this contract.

3. LAWS AND REGULATIONS

The Contractor shall conform to all the applicable rules, regulations, laws and ordinances of the City of Waltham, the Commonwealth of Massachusetts, the United States of America and all agencies having jurisdiction over this contract.

4. PROTECTION OF PROPERTY

The Contractor shall take all proper precautions to protect the City’s property from damage and unnecessary inconvenience. Any City property damaged by the Contractor in carrying out the provisions of this contract shall be restored to its original condition, by and at the expense of the Contractor.

5. PROTECTION OF PERSONS

The Contractor shall take all proper precautions to protect persons from injury, unnecessary inconvenience, and shall be responsible for his failure to do so. The Contractor agrees to hold the City harmless from any and all liabilities of every nature and description, which may be suffered through bodily injury, including death, to any person, by reason of negligence of the Contractor, his agents or employees, or any subcontractor.

6. CONTRACT DURATION.

This contract is for the period required to complete the project. The project is to be completed in 150 days from the date of The Notice to Proceed (NTP) and excluding the final paving.



7. INSURANCE

A. WORKMAN’S COMPENSATION: The Contractor shall provide insurance for the payment of compensation and furnishing of other benefits under Chapter 152 of the General Laws of the Commonwealth of Massachusetts to all persons to be employed under this contract, the premiums for which shall be paid by the Contractor. Contractors shall provide insurance on a primary basis and the contractor’s policy shall be exhausted before resorting to other policies. The contractor’s policy is the primary one not the contributory.

B. COMPREHENSIVE GENERAL LIABILITY

Bodily Injury:	\$1,000,000 Each Occurrence
	\$2,000,000 Aggregate
Property Damage:	\$1,000,000 Each Occurrence
	\$2,000,000 Aggregate

C. AUTOMOBILE (VEHICLE) LIABILITY

Bodily Injury	\$2,000,000 Each Occurrence
Property Damage	\$1,000,000 Aggregate

D. UMBRELLA POLICY

General liability	\$1,000,000
-------------------	-------------

Your bid response must include a Certificate of Insurance with the above limits as a minimum. In addition, the Certificate of Insurance must have the following text contained in the bottom left box of the Certificate: *“The City of Waltham is a named additional insured for all insurances under the contract, excluding Automobile and Workers Compensation coverage”*. The Certificate of Insurance must be mailed directly to:

Office of the Purchasing Agent  
Purchasing Department  
City of Waltham  
610 Main Street  
Waltham, MA 02452

8. LABOR AND MATERIALS BOND

The Contractor agrees to execute and deliver to the City, a Labor and Materials and Payment Bond equal to 50% of the contract value. This contract shall not be in force until said bond has been delivered and accepted by the City. Bond to be issued by a company licensed by the Commonwealth of Massachusetts.

**A LETTER FROM A SURETY COMPANY CERTIFYING THAT THE CONTRACTOR IS QUALIFIED AND CAPABLE OF OBTAINING THE ABOVE BONDS MUST BE INCLUDED WITH HIS/HERS BID.**

9. PERSONNEL:

The Contractor shall employ a competent supervisor and all properly licensed personnel necessary to perform the services required in this contract. The City Purchasing Agent shall have the right to require the Contractor to remove and/or replace any of the personnel for nonperformance or for unprofessional behavior. The City Purchasing Agent may require the Contractor to submit a weekly performance record of the areas and of the work performed, on forms approved by the City Purchasing Agent. The Contractor or his supervisor shall be available to inspect such work as required by the City Purchasing Agent.

10. PREVAILING WAGES

The Contractor is required to pay the prevailing wages as determined under the provisions of Chapter 149, Sections 26 and 27D of the Massachusetts General Laws, including the submission of weekly payrolls to the awarding authority. The prevailing Wage Schedule is available at [www.city.waltham.ma.us/open-bids](http://www.city.waltham.ma.us/open-bids)

11. MATERIALS

The City or its Agent reserves the right to approve or reject any supplies, material or equipment used by the Contractor. The Contractor agrees to replace any supplies, material or equipment used by the Contractor. The Contractor agrees to replace any rejected supplies, materials or equipment, to the satisfaction of the City or its Agents.

12. TERMINATION OF CONTRACT

This contract may be terminated by the City upon deliverance to the Contractor of a five-day written notice of said termination.

13. CONTRACT OBLIGATIONS

Contract obligations on behalf of the City are subject to an annual appropriation to cover the contract obligation.

14. BIDDER EXPERIENCE EVALUATION

Each bidder shall submit with his bid, all the information relative to their experience and qualifications in performing the work required under this contract and shall have been in business for a minimum of five (5) years, in order for their bid to be considered.

15. NOT-TO-EXCEED AMOUNT

The bid amount proposed in your company's response is a "not-to- Exceed" amount unless the City makes changes, in writing, to the scope of work to be performed. The Change Order must be signed and approved by the City's Purchasing Agent, City Auditor, Law Department and the Mayor prior to the commencement of the change order work. No work is to begin until the proper approvals have been obtained. A change order will be priced at the unit price. Failure to comply with this procedure will result in the cancellation of the contract and the non-payment of services provided

16. FINANCIAL STATEMENTS.

The City may require, within five (5) days after the bid opening, a complete and detailed Financial Statement prepared by a Certified Public Account, to determine a bidder's financial stability.

17. BREACH OF CONTRACT/ NON PERFORMANCE

If the Contractor shall provide services in a manner, which is not to the satisfaction of the City, the City may request that the Contractor refurnish services at no additional cost to the City until approved by the City. If the Contractor shall fail to provide services, which are satisfactory to the City, the City in the alternative may make any reasonable purchase or Contract to purchase services in substitution for those due from the Contractor.

The City may deduct the cost of any substitute Contract for nonperformance of services together with incidental and consequential damages from the Contract price and shall withhold such damages from sums due or to become due to the Contractor. If the damages sustained by the City exceed sums due or to become due, the Contractor shall pay the difference to the City upon demand. The Contractor shall not be liable for any damages sustained by the City due to the Contractor's failure to furnish services under the terms of this Contract if such failure is in fact caused by the occurrence of a contingency the nonoccurrence of which was a basic assumption under which this Contract was made, including a state of war, embargoes, expropriation of labor strike or any unanticipated federal, state or municipal governmental regulation of order, provided that the Contractor has notified the City in writing of such cause within seven (7) days after its occurrence.

18. RIGHT TO AUDIT

The City of Waltham has the right to review and audit documents related to this contract. This right extends to any subcontractor, supplier or other entity used by the prime contractor to fulfill the obligations under this contract.

19. CITY ORDINANCE. APPROVAL OF CONTRACTS BY MAYOR, SEC. 3-12 OF THE CITY ORDINANCES.

All contract made by any department, board or commission where the amount involved is two thousand dollars (\$2,000) or more shall be in writing, and no such contract shall be deemed to have been made or executed until the approval of the Mayor is affixed thereto. Any construction contract shall, and all other contracts may, where the contract exceed five thousand dollars (\$5,000) be required to be accompanied by a bond with sureties satisfactory to the Mayor.

## **Division 1 – General Requirements**

## SECTION 01010

### SUMMARY OF WORK

#### PART 1-GENERAL

##### 1.1 LOCATION OF WORK

- A. The work of this Contract is located on and/or adjacent to private property of residences at miscellaneous locations in Waltham, Massachusetts as shown on the Drawings included in this Contract.

##### 1.2 SCOPE OF WORK

- A. The Work under this Contract includes private inflow removal at up to fifty six (56) properties. The work includes, but is not necessarily limited to, disconnecting sump pumps from existing sanitary sewer and connecting to either the existing storm drain system, a new storm drain, or an on-site infiltration system. This work also includes the installation of new storm drains and the installation of on-site infiltration systems, including fittings, and connections to connect private inflow sources to either the existing storm drain system, a new storm drain or an on-site infiltration system; penetrations through existing foundations to extend new internal plumbing for storm drain connections; Coordination with the City of Waltham to establish appointments to execute the work at each residence and for inspection of completed work; and all appurtenances and incidental work necessary to complete this Contract in its entirety as shown on the Drawings and as specified herein.
- B. Approximately 163 linear feet of new storm drain and appurtenances on Lakeview Terrace and lateral connectivity to pressure pipe discharges from sump pumps.

##### 1.3 CONTRACTOR'S USE OF PREMISES

- A. Contractor shall limit the use of the premises for his/her Work to minimize disruption to home owner. The Contractor shall not use sites for storage of equipment or material.
- B. Obtain and pay for use of additional storage or work areas if needed to perform the Work.
- C. Coordinate use of premises with the Waltham Department

##### 1.4 OWNER OCCUPANCY

- A. A general description of the work to be performed under this contract shall include, but will not be limited to, the following construction operations:
  - 1. Coordination of all construction activities with the appropriate local and State authorities and utilities.

### SUMMARY OF WORK

01010-1

2. Attending the pre-construction conference and required job progress meetings.
3. Submission of a construction schedule, list of subcontractors and submission of all required shop drawings, in a timely manner, to the Engineer for review.
4. Mobilization to the site.
5. Protection of existing structures and installation of environmental control measures.

## 1.5 UTILITIES

- A. The utilities shown on the plans have been located primarily from information furnished by others and are considered approximate both as to size and location. It shall be the Contractor's responsibility to locate all existing utilities and to protect same from damage or harm. All utilities interfered with or damaged shall be properly restored, at the expense of the Contractor, to the satisfaction of its Owner.
- C. The following is a partial list of Owners of Utilities:

**Water, Storm Drain and Sewer:**  
**Waltham Consolidated Public Works Department**  
163 Lexington Street  
Waltham, MA 02452  
Telephone: (781) 314-3832

**Electric:**  
NStar Electric  
Telephone: (800) 592-2000

**Gas:**  
National Grid  
Telephone: (800) 233-5325

**DIGSAFE: (800) 344-7233**

PART 2- PRODUCTS (NOT USED)

PART 3- EXECUTION (NOT USED)

END OF SECTION 01010

## SUMMARY OF WORK 01010-2

## SECTION 01024

### MEASUREMENT AND PAYMENT

#### PART I-GENERAL

##### 1.1 SUMMARY

- A. Under the price specified to be paid for each item, the Contractor shall furnish all materials and equipment, furnish all labor and plant and perform all operations to complete all work as indicated and specified. Provide all supervision, overhead items, insurance, bond and permit costs, protection and precautions and all other costs, incidental to the construction work, complete, and as specified, are also included.
- B. A complete, finished, working job, as intended by the general nature of these Specifications, shall be produced whether or not any particular wording or direction is omitted or inadvertently not clearly stated.
- C. Measurement for payment shall be by the Engineer, except where noted elsewhere in this Specification. Measurement for payment for lump sum items shall be on the basis of percentage of work complete and in place.
- D. Each unit or lump sum price stated in the Bid shall constitute full compensation as herein specified for each item of work completed in accordance with the Drawings and Specifications.
- E. The prices for those items which involve excavation shall include compensation for disposal of surplus excavated material, dewatering, earth support, and handling and disposal of water.
- F. The prices for all pipe items shall constitute full compensation for furnishing, laying, jointing, and testing of pipe; excavation and backfill; and clean up.
- G. In all items involving excavation, the price shall be based on doing the entire excavation in earth. Where rock is excavated, the price thereof shall be in addition to the cost of excavating earth, and no deduction will be made in the amount for earth excavation.
- H. Unit prices submitted for various items of work will be utilized for determining prices of any additional work necessary during construction.
- I. Final payment shall not be issued until the Contractor submits record drawings and the Engineer approves these drawings. .

### MEASUREMENT AND PAYMENT

01024-1



1.2 ITEM DESCRIPTIONS-BASE BID

**Item 1: Mobilization and Demobilization:**

1. For the Lump sum bid price for this Item, the Contractor shall mobilize and demobilize to and from the site all labor, materials, and equipment to complete all work associated with this contract. Demobilization from the site includes, but is not limited to: removal of all equipment and final cleanup to the satisfaction of the City.
2. Payment for the mobilization and demobilization shall be by lump sum. Fifty percent of the lump sum price shall be paid to the Contractor upon completing mobilization activities, and the remaining fifty percent shall be paid upon demobilization from the site.

**Item 2: Private inflow Removal and Sump Pump Discharge Redirection to an On-Site Infiltration System.**

1. Under the lump sum bid price for this Item, the Contractor shall provide all necessary materials equipment and labor to execute the work as specified and as shown on the drawings.
2. Payment for this lump sum Item shall be made based on the percentage of work completed, as determined by the Engineer.

Under the lump sum bid price for this Item, the Contractor shall provide all necessary materials, equipment and labor to connect sump pumps to a new infiltration basin, including site restoration. The price shall include disconnecting the existing discharge pipe from the sanitary sewer, plugging the connection to the sewer, all interior and exterior piping work necessary for redirection of the sump pump discharge to and connection to a new infiltration basin as shown on the drawings. Work shall include scheduling and coordinating with property owners, verification of existing pipe sizes, coring, cutting and patching in walls and foundations, grouting of openings and corings, protection of private property and utilities, excavation, dewatering, backfill and compaction, restoration, and disposal of any water; and maintenance of flow during construction. Work shall include furnishing and installing a new check valve and fittings on each existing sump pump discharge, and all pipe hangers, supports and fittings; and disposal of existing piping connected to the sanitary sewer and disposal of excess material and debris; and resetting any disturbed curbs, walkways, driveways, retaining walls, landscaping or any other site features disturbed during construction. Pavement shall include temporary trench pavement and permanent pavement.

3. Full payment shall not be made until the piping is tested to the satisfaction of the Engineer and the property is restored to its pre-construction condition.
5. Payment shall be per unit as listed on the Bid Form.

MEASUREMENT AND PAYMENT  
01024-2

**Item 3: Private inflow Removal and Sump Pump Discharge Redirection and Connection to the Existing Drainage System.**

1. Under the lump sum bid price for this Item, the Contractor shall provide all necessary materials equipment and labor to execute the work as specified and as shown on the drawings.
2. Payment for this lump sum Item shall be made based on the percentage of work completed, as determined by the Engineer.

Under the lump sum bid price for this Item, the Contractor shall provide all necessary materials, equipment and labor to connect sump pumps to the existing storm drain system, including site restoration. The price shall include disconnecting the existing discharge pipe from the sanitary sewer, plugging the connection to the sewer, all interior and exterior piping work necessary for redirection of the sump pump discharge to and connection to the existing storm drain pipe or structure in the street. Work shall include scheduling and coordinating with property owners, verification of existing pipe sizes, coring, cutting and patching in walls and foundations, grouting of openings and corings, protection of private property and utilities, excavation, dewatering, backfill and compaction, restoration, and disposal of any water; and maintenance of flow during construction. Work shall include a furnishing and installing a new check valve and fittings on each existing sump pump discharge, and all pipe hangers, supports and fittings; and disposal of existing piping connected to the sanitary sewer and disposal of excess material and debris; and resetting any disturbed curbs, walkways, driveways, retaining walls, landscaping or any other site features disturbed during construction. Pavement shall include temporary trench pavement and permanent pavement.

3. Full payment shall not be made until the piping is tested to the satisfaction of the Engineer and the property is restored to its pre-construction condition.
4. Payment shall be per unit as listed on the Bid Form.

**Item 4: Private inflow Removal and Sump Pump Discharge Redirection and Connection to the New Storm Drain.**

1. Under the lump sum bid price for this Item, the Contractor shall provide all necessary materials equipment and labor to execute the work as specified and as shown on the drawings.
2. Payment for this lump sum Item shall be made based on the percentage of work completed, as determined by the Engineer.

Under the lump sum bid price for this Item, the Contractor shall provide all necessary materials, equipment and labor to connect sump pumps to the new storm drain system, including site restoration. The price shall include disconnecting the existing discharge pipe from the sanitary sewer, plugging the connection to the sewer, all interior and exterior piping work necessary for redirection of the sump pump discharge

**MEASUREMENT AND PAYMENT**

01024-3

to and connection to a new drain as shown on the drawings. Work shall include scheduling and coordinating with property owners, verification of existing pipe sizes, coring, cutting and patching in walls and foundations, grouting of openings and corings, protection of private property and utilities, excavation, dewatering, backfill and compaction; disposal of any water; and maintenance of flow during construction. Work shall include a furnishing and installing a new check valve and fittings on each existing sump pump discharge, and all pipe hangers, supports and fittings; and disposal of existing piping connected to the sanitary sewer and disposal of excess material and debris; and resetting any disturbed curbs, walkways, driveways, retaining walls, landscaping or any other site features disturbed during construction. Pavement shall include temporary trench pavement and permanent pavement.

3. Full payment shall not be made until the piping is tested to the satisfaction of the Engineer and the property is restored to its pre-construction condition.
4. Payment shall be per unit as listed on the Bid Form.

#### **Item 5: New Storm Drain Piping (12" RCP) and Appurtenances on Lakeview Terrace**

1. Under the unit bid price for this Item, the Contractor shall provide all necessary materials equipment and labor to execute the work as specified and as shown on the drawings.
2. Payment for this item shall be made based on the percentage of work completed as determined by the Engineer.
3. The Contractor shall provide all necessary materials, equipment and labor to furnish and install the storm drain pipe and appurtenances (one manhole, two wye fittings, piping from new manhole to an existing manhole) including paving and site restoration. Work shall include scheduling and coordinating the work, verification of existing pipe sizes, coring, cutting and patching at the connection to the existing system, grouting of openings and corings, protection of private and public property and utilities, excavation, dewatering, backfill and compaction; disposal of any water; and maintenance of flow during construction. Work shall include disposal of excess material and debris; and resetting any disturbed curbs, walkways, driveways, retaining walls, landscaping or any other site features disturbed during construction. Pavement shall include temporary trench pavement and permanent pavement.
4. Full payment shall not be made until the piping is tested to the satisfaction of the Engineer and the property is restored to its pre-construction condition.
5. Payment shall be per unit as listed on the Bid Form.

#### **Item 6: Environmental Protection Controls**

1. Under the unit bid price for this Item, the Contractor shall provide all necessary materials equipment and labor to execute the work as specified and as shown on the drawings.

### **MEASUREMENT AND PAYMENT**

01024-4

2. Payment for this lump sum Item shall be made based on the percentage of work completed, as determined by the Engineer.
3. The Contractor shall provide all environmental protection measures such as straw bales, silt fences, fabric wraps under existing catch basin grates, and all other protective measures necessary during construction.
4. Controls shall be removed upon completion of the work.

#### **Item 7: Rock Excavation and Disposal**

1. Under the unit bid price for this Item, the Contractor shall provide all necessary materials equipment and labor to execute the work as specified and as shown on the drawings.
2. Measurement for payment will be on the basis of cubic yards of ledge or rock excavated as measured by the Engineer.
3. Under the unit price bid for this item, the Contractor shall excavate, remove, and dispose of ledge and rock from trenches and excavated areas. Included in the price bid per cubic yard shall be related costs such as drilling, blasting, and replacement with suitable gravel borrow material, removal, and disposal of excavated material.
4. Rock in pipe trenches shall be measured from its surface to 6-inches below the outside of the pipe and with a width of two (2) feet greater than the inside diameter of the pipe but not less than 3 feet minimum trench width. Any rock excavated to a depth or width greater than the above shall be removed and backfilled with common fill at the Contractor's expense.

#### **Item 8:-All Other Work/Remaining Lump Sum Items**

1. Under the lump sum price for this Item, the Contractor shall provide all general construction services, labor, materials, supplies, consumables, and equipment necessary to complete all work required to construct the work identified on the Drawings and in the Specifications, which is not included in all other Bid Items. This shall include, but is not limited to, the following:
  - a. Attending the pre-construction conference and all required job progress and community meetings, and coordination of all construction activities with the appropriate local authorities and utilities. Submission of construction photographs of completed work at each property
  - b. Submission of all schedules, lists, laboratory test results, materials and sources, and shop drawings, photographs before and after construction, as required, in a timely manner to the Engineer for review and approval.
  - c. Maintenance and repair of all work for one (1) year period.

#### MEASUREMENT AND PAYMENT 01024-5

- d. Providing a Site-Specific Health and Safety Plan for the Contractor's employees in accordance with the minimum standards set forth in OSHA 29 CFR 1910.120 and 29 CFR 1926.
  - e. Implementation of the Health and Safety Plan.
  - f. Construction, maintenance, and removal of equipment from any staging or wash down areas.
  - g. Erosion Control measures to prevent exposed fill, excavated material, or other materials from washing away or otherwise eroding from slopes or into wetlands.
  - h. Coordination of all construction activities with the City of Waltham.
  - i. All other project related direct and indirect costs not described above.
2. Payment for this lump sum item will be based on a percentage of the work completed, as determined by the Engineer.

**Item9: Police Detail Allowance**

- 1. Police officers if necessary shall be authorized by the City and the Engineer and used for traffic management around construction zones.
- 2. Payment shall be on a unit basis (per hour).

**Item 10: Cut and Splash Roof Leaders Allowance**

- 1. Under the unit bid price for this Item, the Contractor shall provide all necessary materials equipment and labor to execute the work as specified and as shown on the drawings.
- 2. Payment for this item shall be made based on the percentage of work completed as determined by the Engineer.
- 3. The Contractor shall provide all necessary materials, equipment and labor to cut and splash existing roof leaders that are connected to building internal plumbing as directed by the Engineer including paving and site restoration. Work shall include scheduling and coordinating the work, verification of existing pipe sizes, coring, cutting and patching at the connection to the existing system, grouting of openings and corings, protection of private and public property and utilities, excavation, dewatering, backfill and compaction; disposal of any water; and maintenance of flow during construction. Work shall include disposal of excess material and debris; and resetting any disturbed curbs, walkways, driveways, retaining walls, landscaping or any other site features disturbed during construction. Pavement shall include temporary trench pavement and permanent pavement.
- 4. Full payment shall not be made until the piping is tested to the satisfaction of the Engineer and the property is restored to its pre-construction condition.

**MEASUREMENT AND PAYMENT**

01024-6

5. Payment shall be per unit as listed on the Bid Form.

END OF SECTION 01024

MEASUREMENT AND PAYMENT  
01024-7

Sump Pump Amnesty Program  
Contract 2- Areas 5B, 5D and 15  
Waltham, Massachusetts

## SECTION 01045

### CUTTING, CORING AND PATCHING

#### PART 1-GENERAL

##### 1.1 RELATED DOCUMENTS

- A. Drawings and general provisions of Contract, including General and Supplementary Conditions and other Division 1 Specification Sections, apply to this section.

##### 1.2 SUMMARY

- A. This section specifies administrative and procedural requirements for cutting, coring, rough and finish, and patching.
- B. Refer to other sections for specific requirements and limitations applicable to cutting, and patching individual parts of the Work.
  - 1. Requirements of this section do not apply to mechanical and electrical installations. Refer to Division 15 and 16 Specification Sections for requirements and limitations applicable to cutting and patching mechanical and electrical installations.

##### 1.3 SUBMITTALS

- A. For informational purposes only, submit proposed cutting and patching well in advance of the time cutting and patching will be performed. Include the following information, as applicable:
  - 2. Describe the extent of cutting and patching required and how it is to be performed; indicate why it cannot be avoided.
  - 3. Describe anticipated results in terms of changes to existing construction; include changes to structural elements and operating components as well as changes in the building's appearance and other significant visual elements.
  - 4. List products to be used and firms or entities that will perform Work.
  - 5. Indicate dates when cutting and patching is to be performed.
  - 6. List utilities that will be disturbed or affected, including those that will be relocated and those that will be temporarily out-of-service. Indicate how long service will be disrupted.

### CUTTING, CORING AND PATCHING

01045-1

7. Where cutting and patching involves addition of reinforcement to structural elements, submit details to show how reinforcement is integrated with the original structure.
8. Review by the Engineer prior to proceeding with cutting and patching does not waive the Engineer's right to later require complete removal and replacement of a part of the Work found to be unsatisfactory.
8. Refer to Paragraph 1.4 - Quality Assurance and submit the information specified.

#### 1.4 QUALITY ASSURANCE

- A. No structural members shall be cut without the approval of the Engineer. No holes shall be drilled in beams or other structural members without the approval of the Engineer.
- B. Requirements for Structural Work: Do not cut and patch structural elements in a manner that would reduce their load-carrying capacity or load-deflection ratio.
- C. Operational and Safety Limitations: Do not cut and patch operating elements or safety related components that would result in reducing their capacity to perform as intended, or result in increased maintenance, or decreased operational life or safety.
- D. Visual Requirements: Do not cut and patch construction exposed on the exterior or in occupied spaces, in a manner that would, in the Engineer's opinion, reduce the building's aesthetic qualities, or result in visual evidence of cutting and patching. Remove and replace Work cut and patched in a visually unsatisfactory manner.
  1. If possible retain the original installer or fabricator to cut and patch the following categories of exposed Work, or if it is not possible to engage the original installer or fabricator, engage another recognized experienced and specialized firm:
    - a. Unit masonry.
    - b. Stucco and plaster.
    - c. Aggregate wall coating.
    - d. HVAC enclosures, cabinets or covers.

#### CUTTING, CORING AND PATCHING 01045-2



## PART 2-GENERAL

### 2.1 MATERIALS

- A. Provide materials that are identical to existing materials. If identical materials are not available or cannot be used where exposed surfaces are involved, use materials that match existing adjacent surfaces to the fullest extent possible with regard to visual effect. Use materials whose installed performance will equal or surpass that of existing materials.
- B. Plaster Soffits: Comply with ASTM C 842.
  - 1. Base Coat: Ready-mixed, sand aggregate gypsum plaster base.
  - 2. Finish Coat Ready-mixed gypsum finish plaster.
- C. Concrete and grout for rough patching shall be as specified in Divisions 3 and 4.

## PART 3 -EXECUTION

### 3.1 INSPECTION

- A. Before cutting existing surfaces examine surfaces to be cut and patched and conditions under which cutting and patching is to be performed. Take corrective action before proceeding, if unsafe or unsatisfactory conditions are encountered.
  - 1. Before proceeding, meet at the site with parties involved in cutting and patching, including mechanical and electrical trades. Review areas of potential interference and conflict. Coordinate procedures and resolve potential conflicts before proceeding.

### 3.2 PREPARATION

- A. Temporary Support and Bracing: Provide temporary support and bracing of area to be cut, prior to start of cutting.
- B. Protection: Protect existing construction during cutting and patching to prevent damage. Provide protection from adverse weather conditions for portions of the Project that might be exposed during cutting and patching operations.
- C. Avoid interference with use of adjoining areas or interruption of free passage to adjoining areas.
- D. Take all precautions to avoid cutting existing conduit or ductwork serving the building, but scheduled to be removed or relocated until provisions have made to bypass them.

## CUTTING, CORING AND PATCHING

01045-3

- E. Check area during sawing operations for partial cracking and provide additional support and bracing to prevent a partial release of cut area during sawing operations.
- F Provide equipment of adequate size to remove cut panels.

### 3.3 PERFORMANCE

- A. General: Employ skilled workmen to perform cutting and patching. Proceed with cutting and patching at the earliest feasible time and complete without delay.
  - 1. Cut existing construction to provide for installation of other components or performance of other construction activities and the subsequent fitting and patching required to restore surfaces to their original condition.
  - 2. All cutting and coring shall be performed in such a manner as to limit the extent of patching.
- B. Cutting: Cut existing construction using methods least likely to damage elements to be retained or adjoining construction. Where possible review proposed procedures with the original installer; comply with the original installer's recommendations.
  - 1. In general, where cutting is required use hand or small power tools designed for sawing or grinding, not hammering and chopping. Cut holes and slots neatly to size required with minimum disturbance of adjacent surfaces. Temporarily cover openings when not in use.
  - 2. To avoid marring existing finished surfaces, cut or drill from the exposed or finished side into concealed surfaces.
  - 3. Cut through concrete and masonry using a cutting machine such as a carborundum saw or diamond core drill.
  - 3. Comply with requirements of applicable sections of Division 2 where cutting and patching requires excavating and backfilling.
  - 4. By pass utility services such as pipe or conduit, before cutting, where services are shown or required to be removed, relocated or abandoned. Cut-off pipe or conduit in walls or partitions to be removed. Cap, valve or plug and seal the remaining portion of pipe or conduit to prevent entrance of moisture or other foreign matter after by-passing and cutting.
  - 6. Provide full control of slurry generated by sawing operations on both

## CUTTING, CORING AND PATCHING

01045-4

sides of wall

7. When cutting a reinforced concrete wall, the cutting shall be done so as not to damage bond between the concrete and reinforcing steel left in structure. Cut shall be made so that steel neither protrudes nor is recessed from face of the cut.

C. Coring

1. All holes cut through concrete and masonry walls, slabs or arches shall be core drilled unless otherwise approved.
2. If holes are cored through floor slabs they shall be drilled from below.
2. Rough patching shall be such as to bring the cut or cored area flush with existing construction unless otherwise shown. Finish patching shall match existing surfaces as approved.
4. Coring shall be performed with an approved non-impact rotary tool with diamond core drills. Size of holes shall be suitable for pipe, conduit, sleeve, equipment or mechanical seals to be installed.
5. All equipment shall conform to OSHA standards and specifications pertaining to plugs, noise and fume pollution, wiring and maintenance.
6. Provide protection for existing equipment, utilities and critical areas against water or other damage caused by drilling operation.
7. Slurry or tailings resulting from coring operations shall be vacuumed or otherwise removed from the area following drilling.

D. Patching: Patch with durable seams that are as invisible as possible. Comply with specified tolerances.

1. Where feasible, inspect and test patched areas to demonstrate integrity of the installation.
2. Restore exposed finishes of patched areas and extend finish restoration into retained adjoining construction a manner that will eliminate evidence of patching and refinishing.
3. Where removal of walls or partitions extends one finished area into another, patch and repair floor and wall surfaces in the new space to provide an even surface of uniform color and appearance. Remove existing floor and wall coverings and replace with new materials, if necessary to achieve uniform color and appearance.

## CUTTING, CORING AND PATCHING

01045-5

4. Where patching occurs in a painted surface, extend final paint coat over entire unbroken area or surface containing the patch, after the patched area has received primer and second coat.
  5. Finish patching shall be the responsibility of the Contractor and shall be performed by the trade associated with the application of the particular finish.
- E. Plaster Installation: Comply with manufacturer's instructions and install thickness and coats as indicated.
1. Unless otherwise indicated provide 3-coat Work.
  2. Finish gypsum plaster with smooth-troweled finish. Sand lightly to remove trowel marks and arises.
  3. Cut, patch, point-up and repair plaster to accommodate other construction and to restore cracks, dents and imperfections.

### 3.4 CLEANING

- A. Thoroughly clean areas and spaces where cutting and patching is performed or used as access. Remove completely paint, mortar, oils, putty and items of similar nature. Thoroughly clean piping, conduit and similar features before painting or other finishing is applied. Restore damaged pipe covering to its original condition.

END OF SECTION 01045

### CUTTING, CORING AND PATCHING 01045-6

SECTION 01046

CONTROL OF WORK

PART I-GENERAL

1.1 EQUIPMENT

- A. Furnish equipment which will be efficient, appropriate and large enough to secure a satisfactory quality of work and a rate of progress which will insure the completion of the work within the Contract Time. If at any time such equipment appears to the Engineer to be inefficient, inappropriate or insufficient for securing the quality of work required or for producing the rate of progress aforesaid, he/she may order the Contractor to increase the efficiency, change the character or increase the plant equipment and the Contractor shall conform to such order. Failure of the Engineer to give such order shall in no way relieve the Contractor of his/her obligations to secure the quality of the work and rate of progress required.

1.2 PRIVATELAND

- A. The Contractor shall not enter or occupy private land outside of easements, except by permission of the land owner.

1.3 HAULING, HANDLING, AND STORAGE OF MATERIALS

- A. The Contractor shall, at his own expense, handle and haul all materials furnished by him and shall remove any and all of his surplus materials at the completion of the work. The Contractor shall provide suitable and adequate storage for equipment and materials furnished by him that are liable to injury, and shall be responsible for any loss or damage to any equipment or materials by theft, breakage, or otherwise. The Contractor shall be responsible for all damages to the work under construction during its progress and until final completion and acceptance, even though partial payments have been made under the Contract.

1.4 PROTECTION AND RELOCATION OF EXISTING STRUCTURES AND UTILITIES

- A. The Contractor shall assume full responsibility for the protection of all buildings, structures, and utilities, public or private, including poles, fences, guardrails, signs, services to buildings, utilities in the street, gas pipes, water pipes, hydrants, sewers, drains, and electric and telephone cables, whether or not they are shown on the Drawings. The Contractor shall carefully support and protect all such structures and utilities from injury of any kind. The Contractor is required to comply with all provisions of General Laws Chapter 353 entitled "Excavations-Public Ways-Notice Requirements", otherwise known as DigSafe. Any damage resulting from the Contractor's operations shall be repaired by him at his expense.

CONTROL OF WORK

01046-1

- B. Assistance will be given the Contractor in determining the location of existing services. The Contractor, however, shall bear full responsibility for obtaining all locations of underground structures and utilities (including, but not limited to existing water services, drain lines, and sewers). Services to buildings shall be maintained, and all costs or charges resulting from damage thereto shall be paid by the Contractor.
- C. Protection and temporary removal and replacement of existing utilities and structures, as described in this Section, shall be a part of the work under the Contract, and all costs in connection therewith shall be included in the unit prices established in the Contract.
- D. If, in the opinion of the Engineer, permanent relocation of a utility owned by the City is required, which is not shown on the Plans or the Specifications, he may direct the Contractor, in writing, to perform the work. Work so ordered will be paid for as extra work under Articles of the General Conditions. If relocation of a privately- owned utility is required, the Town will notify the utility to perform the work as expeditiously as possible. The Contractor shall fully cooperate with the City and utility, and shall have no claim for delay due to such relocation. The Contractor shall notify public utility companies, in writing, at least 72 hours (excluding Saturdays, Sundays, and legal holidays) before excavating in any public way.

#### 1.5 PIPE LOCATIONS

- A. Pipelines shall be located substantially as indicated on the Drawings, but the Engineer reserves the right to make such modifications in locations as may be found desirable to avoid interference with existing structures or for other reasons. Where fittings are noted on the Drawings, such notation is for the Contractor's convenience and does not relieve him/her from laying and jointing different or additional items where required.

#### 1.6 OPEN EXCAVATIONS

- A. All open excavations shall be adequately safeguarded by providing temporary barricades, caution signs, lights and other means to prevent accidents to persons and damage to property. The Contractor shall, at his/her own expense, provide suitable and safe bridges and other crossings for accommodating travel by pedestrians and workmen. Bridges provided for access during construction shall be removed when no longer required. The length or size of excavation will be controlled by the particular surrounding conditions, but shall always be confined to the limits prescribed by the Engineer. If the excavation becomes a hazard, or if it excessively restricts traffic at any point, the Engineer may require special construction procedures such as limiting the length of the open trench, prohibiting stacking excavated material in the street requiring that the trench shall not remain open overnight.
- B. The Contractor shall take precautions to prevent injury to the public due to open trenches. All trenches, excavated material, equipment, or other obstacles which could be dangerous to the public shall be well lighted at night.

### CONTROL OF WORK 01046-2

## I.7 TEST PITS

- A. Test pits for the purpose of locating underground pipeline or structures in advance of the construction shall be excavated and backfilled by the Contractor at the direction of the Engineer. Test pits shall be backfilled and compacted immediately after their purpose has been satisfied and the surface restored and maintained in a manner satisfactory to the Engineer.

## 1.8 MAINTENANCE OF TRAFFIC

- A. Unless permission to close a street is received in writing from the proper authority, all excavated material shall be placed so that vehicular and pedestrian traffic may be maintained at all times. If the Contractor's operations cause traffic hazards, he/she shall repair the road surface, provide temporary ways, erect wheel guards or fences, or take other measures for safety satisfactory to the Engineer.
- B. Detours around construction will be subject to the approval of the Owner and the Engineer. Where detours are permitted the Contractor shall provide all necessary barricades and signs as required to divert the flow of traffic. While traffic is detoured the Contractor shall expedite construction operations and periods when traffic is being detoured will be strictly controlled by the Owner.
- C. The Contractor shall take precautions to prevent injury to the public due to open trenches. Night watchmen may be required where special hazards exist, or police protection provided for traffic while work is in progress. The Contractor shall be fully responsible for damage or injuries whether or not police protection has been provided.
- D. When, in the opinion of the Police Department, public safety requires the services of police, the Safety Officer may direct the Contractor to provide manpower to direct traffic within the location of work under this Contract.
- E. Under normal circumstances the City of Waltham shall coordinate the scheduling of all police activities, however, when so directed, the Contractor shall make all arrangements in obtaining the manpower and all invoices for policing.
- F. The intent is to insure public safety by police direction of traffic. Police are not to serve as watchmen to protect the Contractor's equipment and materials, or to warn pedestrians of such hazards as open trenches.
- G. Nothing contained herein shall be construed as relieving the Contractor of any of his/her responsibilities for protection of persons and property under the terms of the Contract.
- H. All payments shall be made to police for work under this Contract as described in Section 01024, MEASUREMENT AND PAYMENT, and shall be supported by the proper documentation.
- I. Contractor shall furnish and maintain traffic control signage throughout the project and at all construction areas. Signs shall be standard signs in compliance with Massachusetts

## CONTROL OF WORK 01046-3

Highway standards. In general the following signs and devices shall be placed and maintained at each side of all work areas:

1. Construction Ahead - 1000 feet
2. Construction Ahead - 500 feet
3. Keep Left/Keep Right
4. End Construction
5. Left/Right Lane Closed Ahead
6. Safety Barrels with flashers
7. Detour Ahead
8. Detour (as required)

- J. It is the intent of this contract that traffic be maintained at all times in the areas of construction. The contractor may be required to halt operations and/or transport material to areas beyond immediate work locations in order to allow minimum traffic disruptions. Access to the site by emergency vehicles, school buses and residents shall be maintained at all times.
- K. The contractor shall be responsible for providing property owners with written notification of proposed construction which may require detours or road closures.

#### 1.9 PROTECTION OF CONSTRUCTION AND EQUIPMENT

- A. All newly-constructed work shall be carefully protected from injury in any way. No placing of heavy loads on it shall be allowed, and all portions injured shall be reconstructed by the Contractor at its own expense.
- B. All structures shall be protected in a manner approved by the Engineer. All such damaged portions of the work shall be completely repaired and made good by the Contractor, at his own expense, and to the satisfaction of the Engineer.
- C. If, in the final inspection of the work, any defects, faults, or omissions are found, the Contractor shall cause the same to be repaired or removed and replaced by proper materials and workmanship, without extra compensation for the materials and labor required. Further, the Contractor shall be fully responsible for the satisfactory maintenance and repair of the construction, and other work undertaken herein, for at least the guarantee period described in the Contract Documents.
- D. The Contractor shall take all necessary precautions to prevent damage to any work during and after construction, and until such work is accepted and taken over by the Owner.

#### 1.10 CARE AND PROTECTION OF PROPERTY AND SURVEY MONUMENTS

- A. The Contractor shall be responsible for the preservation of all public and private property, and shall use every precaution necessary to prevent damage thereto. If any direct or indirect damage is done to public or private property, by or on account of any act, omission, neglect, or misconduct in the execution of the work on the part of the Contractor, such property shall be restored by the Contractor, at his expense, to a

### CONTROL OF WORK 01046-4



condition similar or equal to that existing before the damage was done, or he shall make good the damage in another manner acceptable to the Engineer.

- B. Along the location of this work, all fences, walks, bushes, trees, shrubbery, and other physical features shall be protected and restored in a thoroughly workmanlike manner. Fences and other features removed by the Contractor shall be replaced in the location indicated on the Drawings as soon as conditions permit. All grass areas beyond the limits of construction, which have been damaged by the Contractor, shall be graded and seeded.
- C. Trees close to the work shall be boxed or otherwise protected against injury. The Contractor shall trim all branches that are liable to damage because of his operations, but in no case shall any trees be cut or removed without prior notification of the Town or other person in charge. All injuries to bark, trunk, limbs, and roots of trees shall be repaired by dressing, cutting, and painting according to approved methods using only approved tools and materials.
- D. The protection, removal, and replacement of existing physical features along the line of work shall be a part of the work under the Contract, and all costs in connection therewith shall be included in the Bid Proposal. The Contractor is responsible for protecting and, if required, re-setting survey monuments (bounds). If a bound is in the way of required excavation, the Contractor will notify the Engineer/Inspector and/or the City Engineering Division with as much notice as possible prior to performing excavation near the bound.

#### 1.11 REJECTED MATERIALS AND DEFECTIVE WORK

- A. Materials furnished by the Contractor and condemned by the Engineer as unsuitable or not in conformity with the Specifications shall forthwith be removed from the work by the Contractor, and shall not be made use of elsewhere in the work. Any errors, defects, or omissions in the execution of the work or in the materials furnished by the Contractor, even though they may have been passed or overlooked or have appeared after the completion of the work, discovered at time before the final payment is made hereunder, shall be forthwith rectified and made good by and at the expense of the Contractor, and in a manner satisfactory to the Engineer. The Contractor shall reimburse the Owner for any expenses, losses, or damages incurred in consequence of any defect, error, omission, or act of the Contractor or his employees, as determined by the Engineer, occurring previous to the final payment.

#### 1.12 COORDINATION WITH LOCAL AGENCIES

- A. The Contractor shall attend a Pre-Construction Meeting to be held at the Engineering Department approximately two weeks prior to start of work. City departments who will also be invited to this meeting include Police, Fire and Conservation. Electric, gas and phone utility companies will also be invited. The contractor will provide the proposed schedule at that time (see Submittals, Section 01300). Any proposed detours will be reviewed with all parties at the Pre-Construction Meeting. If any additional detours are considered after the Pre-Construction Meeting, the Contractor must first get approval from the Engineer.

### CONTROL OF WORK 01046-5

- B. The Contractor will immediately notify the utility owner of any utility main breaks.
- C. The Contractor will be required to reimburse the Owner for the actual cost of the services of the Department of Public Works Personnel required during other than regular working hours. This includes the cost of the Engineer/ Site Inspectors when inspection is required outside the normal business hours. This cost shall be at the rate of time and one-half of the Inspector's pay rate, to be paid to the City by the Contractor.
- D. The Contractor shall notify the City at least 72 hours prior to the construction of any public improvement so that the City can have an inspector present if work requires inspection. In general, inspection will be required:
  - 1. For Road Construction:
    - a. When the subgrade is established,
    - b. while placing gravel,
    - c. when final grade of base course is established, and
    - d. during paving operations.
  - 2. For Drainage, Water and Sewer Construction:
    - a. While laying pipe, but before backfilling, and
    - b. during backfilling operations. (In the case of water main installations, final pressure test will be monitored by the Engineer after disinfection tests have been successfully completed.)
    - c. during paving operations.
- E. The Engineer will have the authority to reject any work or materials that do not constitute approval by the City and shall not relieve the Contractor of his obligations to perform the work in accordance with the Plans and Specifications.
- F. The Contractor shall maintain pavement as specified in Section 02576 and shall provide the Engineering Department and Department of Public Works with contact information at which he/she can be contacted when he/she is not at the site. Upon notification by the Owner or the Engineer the Contractor shall promptly make repairs to the construction site as may be necessary.
- G. The Contractor shall assume full responsibility for the protection of all buildings, structures, and utilities, public or private, including poles, signs, services to buildings, utilities in the street, gas pipes, water pipes, hydrants, sewers, drains, curbing, electric and telephone cables, whether or not they are shown on the drawings. The Contractor shall carefully support and protect all such structures and utilities from injury of any kind. .Any damage resulting from the Contractor's operations shall be repaired by him/her at his/her expense.
- H. Assistance will be given the Contractor in determining the location of existing services. The Contractor, however, shall bear full responsibility for obtaining all locations of underground structures and utilities (including existing water services, drain lines and sewers). Services to buildings shall be maintained, and all costs or charges resulting from damage thereto shall be paid by the Contractor.

**CONTROL OF WORK**  
01046-6

- I. Protection and temporary removal and replacement of existing utilities and structures as described in this Section shall be a part of the work under the Contract and all costs in connection therewith shall be included in the Total Price Bid in the Bid Form.
- J. The Contractor shall coordinate the removal and replacement of traffic loops and signals, if required for the performance of the work, at no additional cost to the Owner.
- K. If, in the opinion of the Engineer, permanent relocation of a utility owned by the City of Waltham is required, he/she may direct the Contractor, in writing, to perform the work. Work so ordered will be paid for as extra work under Article II of the Supplementary Conditions. If relocation of a privately owned utility is required, the Department of Public Works will notify the Utility to perform the work as expeditiously as possible. The Contractor shall fully cooperate with the Waltham Engineering Department and the Utility and shall have no claim for delay due to such relocation. The Contractor shall notify all utility companies in writing at least 72 hours (excluding Saturdays, Sundays and Legal holidays) before excavating in any public way. Contractor shall also notify Massachusetts Dig Safe, telephone 1-800-322-4844 at least 72 hours prior to start of work. .

The following is a partial list of Owners of Utilities: Water, Storm Drain and Sewer:

**Waltham Engineering Department**

119 School Street  
Waltham, MA 02451  
Telephone: (781) 314-3844

**Electric:**

NStar Electric  
Telephone: (800)592-2000

**Gas:**

National Grid  
Telephone: (800) 233-5325

**DIGSAFE:** (800) 344-7233

1.13 WATER FOR CONSTRUCTION PURPOSES

- A. In locations where water is in sufficient supply, the Contractor may be allowed to use water without charge for jetting backfill and other construction purposes. The express approval of the Owner shall be obtained before water is used. Waste of water by the Contractor shall be sufficient cause for withdrawing the privilege of unrestricted use.
- B. The Contractor shall furnish all water required for and in connection with work to be done under this Contract including but not limited to: water for cleaning and testing all pipelines, manholes and structures: temporary potable water: sanitation and toilet facilities: disinfection: and including water curing, heating, chemical mixing and testing for permanent pipeline liner rehabilitation system.

**CONTROL OF WORK**

01046-7

- C. No separate measurement and payment shall be made for temporary water and all costs shall be incidental to and included with each applicable item..

#### 1.14 MAINTENANCE OF FLOW

- A. The Contractor shall maintain the flow in all watercourses, whether open channels or in pipes, in all sewers and other pipes interfered with in the line of work and convey the flow to a suitable point of discharge so as not to flow upon the work or create a nuisance. In the discharge of water removed from the excavations by pumping or by gravity similar precautions shall be observed.

#### 1.15 COOPERATION WITHIN THIS CONTRACT

- A. All firms or persons authorized to perform any work under this Contract shall cooperate with General Contractor and his/her Subcontractors or trades and shall assist in incorporating the work of other trades where necessary or required.
- B. Cutting and patching, drilling and fitting shall be carried out where required by the trade or subcontractor having jurisdiction, unless otherwise indicated herein or directed by the Engineer.

#### 1.16 CLEANUP AND DISPOSAL OF EXCESS MATERIAL

- A. During the course of the work, the Contractor shall keep the site of his/her operations in as clean and neat a condition as is possible. He/She shall dispose of all residue resulting from the construction work and at the conclusion of the, he/she shall remove and haul away any surplus excavation, broken pavement, lumber, equipment, temporary structures and any other refuse remaining from the construction operations and shall leave the entire site of the work in a neat and orderly condition.
- B. In order to prevent environmental pollution arising from the construction activities related to the performance of this Contract, the Contractor and his/her subcontractors shall comply with all applicable Federal, State and local laws and regulations concerning waste material disposal, as well as the specific requirements stated in this Section and elsewhere in the Specifications.
- C. The Contractor is advised that the disposal of excess excavated material in wetlands, stream corridors and plains is strictly prohibited even if the permission of the property owner is obtained. Any violation of this restriction by the Contractor or any person employed by him, will be brought to the immediate attention of the responsible regulatory agencies, with a request that appropriate action be taken against the offending parties. Therefore, the Contractor will be required to remove the fill at his/her own expense and restore the area impacted.
- D. Outdoor burning of rubbish and waste material on the site will not be permitted.
- E. Disposal of volatile fluid wastes (such as mineral spirits, oil, gasoline, or paint thinner) in storm or sanitary sewer systems or into streams or waterways is not permitted.

#### CONTROL OF WORK 01046-8

- F. The Contractor shall restore or replace, when and as directed, any public or private property damaged by his work, equipment, or employees, to a condition at least equal to that existing immediately prior to the beginning of operations. To this end the Contractor shall do as required all necessary highway or driveway, walk, and landscaping work. Suitable materials, equipment, and methods shall be used for such restoration. The restoration of existing property or structures shall be done as promptly as practicable as work progresses and shall not be left until the end of the contract period.

#### 1.17 INTERRUPTION OF WATER SERVICE

- A. The Contractor shall plan his work and shall follow a procedure so as not to inconvenience the general public.
- B. All affected customers shall be notified with a minimum of 24 hours notice prior to interruption of water service. Residential notification cards shall be obtained from the Waltham Engineering Department. It shall be the Contractor's responsibility to request and obtain the Residential notification cards from the Waltham Engineering Department
- C. A list of all recipients of notices will be provided to the Waltham Engineering Department immediately.
- D. Failure to comply with notification requirements may result in temporary termination of work until such time that notification is issued. Such termination of work will not be reason for extending contract time limits (see Articles 3 & 7 of the Agreement).
- E. The 24 hour notice requirement is for planned interruptions. Unplanned interruptions require immediate notification of the Waltham Engineering Department (781) 314-3844. Unplanned interruptions are those that could not possibly have been foreseen. Interruptions such as failure of an isolation valve to provide a tight seal when there are personnel such as the Engineer or other City staff who could provide information as to the reliability of a valve are considered interruptions that should be planned.

END OF SECTION 01046

#### CONTROL OF WORK 01046-9

SECTION 01080

ABBREVIATIONS AND DEFINITIONS

PART I-GENERAL

1.1 RELATED DOCUMENTS:

- A. Drawings and general provisions of the Contract, including General and Supplementary Conditions and other Division 1 Specification Sections, apply to this section.

1.2 ABBREVIATIONS:

- A. Where any of the following abbreviations are used in the Contract Documents, they shall have the meaning set forth opposite each.

AASHTO	American Association of State Highway and Transportation Officials
ACI	American Concrete Institute
AISC	American Institute of Steel Construction
ANSI	American National Standards Institute
ASCE	American Society of Civil Engineers
ASTM	American Society for Testing and Materials
AWWA	American Water Works Association
Fed. Spec.	Federal Specifications issued by the Federal Supply Service of the General Services Administration, Washington, D. C.
125-lb. ANSI or 250 lb. ANSI	American National Standard Institute for Cast-iron 250-lb. ANS Pipe Flanges and Flanged Fittings, Designation B16.1, for the Appropriate class
AWG	American or Brown and Sharpe Wire Gage
NPT	National Pipe Thread
OSHA	Occupational Safety and Health Act.
OS&Y	Outside screw and yoke
Stl. WG	U. S. Steel Wire, Washburn and Moen, American Steel and Wire or

ABBREVIATIONS AND DEFINITIONS

01080-1

	Roebing Gage
USS Gage	United States Standard Gage
UL	Underwriters' Laboratories

1.3 DEFINITIONS:

- A. Wherever the words defined in this section or pronouns used in their stead occur in the Contract Documents, they shall have the meanings herein given.
- B. General: Basic Contract definitions are included in the Conditions of the Contract
- C. Indicated: The term indicated refers to graphic representations, notes, or schedules on the Drawings, or other Paragraphs or Schedules in the Specifications, and similar requirements in the Contract Documents. Terms such as shown, noted, scheduled, and specified are used to help the reader locate the reference. There is no limitation on location.
- D. Directed: Terms such as directed, requested, authorized, selected, approved, required, and permitted mean directed by the Engineer, requested by the Engineer, and similar phrases.
- E. Approve: The term approved, when used in conjunction, with the Engineer's action on the Contractor's submittals, applications, and requests, is limited to the Engineer's duties and responsibilities as stated in the Conditions of the Contract.
- F. Regulation: The term regulations includes laws, ordinances, statutes, and lawful orders issued by authorities having jurisdiction, as well as rules, conventions, and agreements within the construction industry that control performance of the Work.
- G. Furnish: The term furnish means supply and deliver to the Project site, ready for unloading, unpacking, assembly, installation, and similar operations.
- H. Install: The term install describes operations at the Project site including the actual unloading, unpacking, assembly, erection, placing, anchoring, applying, working to dimension, finishing, curing, protecting, cleaning, and similar operations.
- I. Provide: The term provide means to furnish and install, complete and ready for the intended use.
  - 1. The term experienced, when used with the term Installer means having a minimum of five previous projects similar in size and scope to this project, being familiar with the special requirements indicated, and having complied with requirements of the authority having jurisdiction.
  - 2. Trades: Using terms such as carpentry is not intended to imply that certain

ABBREVIATIONS AND DEFINITIONS

01080-2

construction activities must be performed by accredited or unionized individuals of a corresponding generic name, such as carpenter. It also does not imply that requirements specified apply exclusively to tradespersons of the corresponding generic name.

- J. Project Site is the space available to the Contractor for performing construction activities, either exclusively or in conjunction, with others performing other work as part of the Project. The extent of the Project Site is shown on the Drawings and may or may not be identical with the description of the land on which the Project is to be built.
- K. Testing Agencies: A testing agency is an independent entity engaged to perform specific inspections or tests, either at the Project Site or elsewhere, and to report on and, if required, to interpret results of those inspections or tests.
- L. Elevation: The figures given on the Drawings or in the other Contract Documents after the word "elevation" or abbreviation of it shall mean the distance in feet above the datum adopted by the Engineer.
- M. Rock: The word "rock," wherever used as the name of an excavated material or material to be excavated, shall mean only boulders and pieces of concrete or masonry exceeding 1 cu. yd. in volume, or solid ledge rock which, in the opinion of the Engineer, requires, for its removal, drilling and blasting, wedging, sledging, barring, or breaking up with a power-operated tool. No soft or disintegrated rock which can be removed with a hand pick or power-operated excavator or shovel, no loose, shaken, or previously blasted rock or broken stone in rock fillings or elsewhere, and no rock exterior to the maximum limits of measurement allowed, which may fall into the excavation, will be measured or allowed as "rock."
- N. Earth: The word "earth", wherever used as the name of an excavated material or material to be excavated, shall mean all kinds of material other than rock as above defined.

PART 2 -PRODUCTS (NOT USED)

PART 3 -EXECUTION (NOT USED)

END SECTION 01080

## ABBREVIATIONS AND DEFINITIONS

01080-3

Sump Pump Amnesty Program  
Contract 2- Areas 5B, 5D and 15  
Waltham, Massachusetts



## SECTION 01110

### ENVIRONMENTAL PROTECTION MEASURES

#### PART I-GENERAL

##### 1.1 SCOPE OF WORK

- A. The work covered by this Section consists of furnishing all labor, materials and equipment and performing all work required for the prevention of environmental pollution in conformance with applicable laws and regulations, during and as the result of construction operations under this Contract. For the purpose of this Specification, environmental pollution is defined as the presence of chemical, physical, or biological elements or agents which adversely affect human health or welfare; unfavorably alter ecological balances of importance to human life; affect other species of importance to man; or degrade the utility of the environment for aesthetic and/or recreational purposes.
- B. The control of environmental pollution requires consideration of air, water and land, and involves management of noise and solid waste, as well as other pollutants.
- C. The Contractor shall take sufficient precautions during construction to minimize the run-off of polluting substances such as silt, clay, fuels, oils, bitumens and calcium chloride into the supplies and surface waters of the State.
- D. Schedule and conduct all work in a manner that will minimize the erosion of soils in the area of the work. Provide erosion control measures such as diversion channels, sedimentation or filtration systems, berms, staked straw bales, seeding, mulching or other special surface treatments as are required to prevent silting and muddying of streams, rivers, impoundments, lakes, etc. All erosion control measures shall be in place in an area prior to any construction activity in that area.
- E. These Specifications are intended to ensure that construction is achieved with a minimum of disturbance to the existing ecological balance between a water resource and its surroundings. These are general guidelines. It is the Contractor's responsibility to determine the specific construction techniques to meet these guidelines.
- F. All phases of sedimentation and erosion control shall comply with and be subject to the approval of the City and the Massachusetts Department of Environmental Protection.

##### 1.2 APPLICABLE REGULATIONS

- A. Comply with all applicable Federal, State and local laws, regulations, and orders of conditions concerning environmental pollution control and abatement.

##### 1.3 NOTIFICATIONS

- A. The Engineer will notify the Contractor in writing of any non-compliance with the foregoing provisions or of any environmentally objectionable acts and corrective action

### ENVIRONMENTAL PROTECTION MEASURES

to be taken. State or local agencies responsible for verification of certain aspects of the environmental protection requirements shall notify the Contractor in writing, through the Engineer, of any non-compliance with State or local requirements. The Contractor shall, after receipt of such notice from the Engineer or from the regulatory agency through the Engineer, immediately take corrective action. Such notice, when delivered to the Contractor or his/her authorized representative at the site of the work, shall be deemed sufficient for the purpose. If the Contractor fails or refuses to comply promptly, the Owner may issue an order stopping all or part of the work until satisfactory corrective action has been taken. No part of the time lost due to any such stop orders shall be made the subject of a claim for extension of time or for excess costs or damages by the Contractor unless it is later determined that the Contractor was in compliance.

#### 1.4 IMPLEMENTATION

- A. Prior to commencement of the work, meet with the Engineer to develop mutual understandings relative to compliance with this provision and administration of the environmental pollution control program.
- B. Remove temporary environmental control features, when approved by the Engineer, and incorporate permanent control features into the project at the earliest practicable time.

### PART2-PRODUCTS

#### 2.1 MANUFACTURERS

- A. Provide the following woven geotextile fabric for silt fence:
  - 1. Amoco 2122 as manufactured by Amoco Fabrics and Fibers Co, Atlanta, GA.
  - 2. Mirafi 100X as manufactured by Mirafi, Pendergrass, GA.
  - 3. Geotex 910SC as manufactured by Synthetic Industry, Chattanooga, TN.
  - 4. Or acceptable equivalent product.

#### 2.2 MATERIALS

- A. Straw or other suitable material acceptable to Engineer. Twine for straw bales shall be biodegradable.
- B. Wood stakes shall be 2 in. by 2 in. by 3ft.
- C. Physical Properties of Minimum Average Roll of the woven geotextile fabric for silt fence shall be:

### ENVIRONMENTAL PROTECTION MEASURES

01110-2

	Property	ASTM Test Method	Units	Value
1.	Grab Strength	D4632	lbs. [N]	100 [450](min.)
2.	Permissivity	D4491	sec- 1	0.10 (min.)
3.	Apparent Opening Size	D4751	Sieve#	20-30
4.	Ultraviolet Stability	D4355	%	70 (min.)

## PART 3 -EXECUTION

### 3.1 INSTALLATION

- A. Install silt fence in accordance with manufacturer's printed instructions.
- B. Overlap silt fence 18 inches [45 cm] minimum for unsewn lap joint. Overlap fabric 6 inches [15 cm] at seam for sewn joint.
- C. Install sedimentation barriers in all locations as directed, surrounding base of all deposits of stored excavated material outside of disturbed area, and where directed by the Engineer.
- D. Install sedimentation barriers immediately after site is cleared and before trench excavation. Locate sedimentation barriers, surrounding stored materials, approximately 6 ft. from material.
- E. Hold bales in place with two 2 in. by 2 in. by 3 ft. stakes so that each bale is butted tightly against ad-joining bale thereby precluding short-circuiting of erosion check.
- F. Construct earth berms or diversions to intercept and divert runoff water from critical areas.
- G. Protect catch basins and drainage swales from sedimentation by installing straw bales around the basin or swale or siltation fabric under catch basin grating casting.
- H. Discharge silt-laden water from excavations onto filter fabric mat and/or baled straw or straw sediment traps to ensure that only sediment-free water is returned to watercourses.
- I. Do not place excavated soil material adjacent to water-course in manner that will cause it to wash away by high water or runoff.
- J. Prevent damage to vegetation by excessive watering or silt accumulation in the discharge area.
- K. Do not dump spoiled material into any streams, wetlands, surface waters, or unspecified locations.

## ENVIRONMENTAL PROTECTION MEASURES

01110-3

- L. Prevent indiscriminate, arbitrary, or capricious operation of equipment in streams, wetlands or surface waters.
- M. Do not pump silt-laden water from trenches or excavations into surface waters, streams, wetlands, or natural or man-made channels leading thereto.
- N. Prevent damage to vegetation adjacent to or outside of construction area limits.
- O. Do not dispose of trees, brush, debris, paints, chemicals, asphalt products, concrete curing compounds, fuels, lubricants, insecticides, washwater from concrete trucks or hydroseeders, or any other pollutant in streams, wet-lands, surface waters, or natural or man-made channels leading thereto, or unspecified locations.
- P. Do not alter flow line of any stream unless indicated or specified.
- Q. Clean and dispose of debris from sedimentation barriers on a weekly basis.
- R. Upon completion of work and upon approval of Conservation Commission and Engineer remove and dispose of sedimentation barriers.

### 3.2 PROVISIONS FOR CONTROL OF EROSION

- A. Special precautions shall be taken in the use of construction equipment to prevent operations which promote erosion. Erosion control measures, such as siltation basins, straw check dams, mulching, jute netting and other equivalent techniques shall be used as appropriate. Flow of surface water into excavated areas shall be prevented.
- B. Disposal of drainage shall be in an area approved by the Owner. The Contractor shall prevent flow or seepage of drainage back into the drainage area. Drainage shall not be disposed of until silt and other sedimentary materials have been removed. Particular care shall be taken to prevent the discharge of unsuitable drainage to a water supply or surface water body.
- C. As a minimum, the following shall apply:
  1. In cross country areas brush and stumps shall not be removed until no more than 1 week prior to the start of pipe laying in that area. The existing ground surface shall be disturbed as little as possible until no more than 1 week prior to the start of pipe laying.
  2. Silt fence and straw bales shall be provided at points where drainage from the work site may contain polluting substances. The point of control shall be within the limits of the new construction and shall be contained in such a way as to not allow sediment to pass. Sufficient bales of straw shall be provided such that all flow will filter through the straw. Other methods which reduce the sediment content to an equal or greater degree may be used as approved by the Engineer.

## ENVIRONMENTAL PROTECTION MEASURES

3. Drainage leaving the site shall flow to water courses in such a manner to prevent erosion.
  4. Loam and seeding or mulching of cross country areas shall take place as soon after laying of the pipeline as practicable. This shall be considered part of the pipeline work and full payment for the pipeline work need not be made until it has been completed.
- D. Measures for control of erosion must be adequate to assure that turbidity in the receiving water will not be increased more than 10 standard turbidity units (s.t.u.), or as otherwise required by the State or other controlling body, in waters used for public water supply or fish unless limits have been established for the particular water. In surface water used for other purposes, the turbidity must not exceed 25 s.t.u. unless otherwise permitted.

### 3.3 PROTECTION OF STREAMS

- A. Care shall be taken to prevent, or reduce to a minimum, any damage to any stream from pollution by debris, sediment or other material, or from the manipulation of equipment and/or materials in or near such streams. Water that has been used for washing or processing, or that contains oils or sediments that will reduce the quality of the water in the stream, shall not be directly returned to the stream. Such waters will be diverted through a settling basin or filter before being directed into the streams.
- B. The Contractor shall not discharge water from dewatering operations directly into any live or intermittent stream, channel, wetlands, surface water or any storm sewer. Water from dewatering operations shall be treated by filtration, settling basins) or other approved method to reduce the amount of sediment contained in the water to allowable levels.
- C. All preventative measures shall be taken to avoid spillage of petroleum products and other pollutants. In the event of any spillage, prompt remedial action shall be taken in accordance with a contingency action plan approved by the Massachusetts Department of Environmental Protection.
- D. Water being flushed from structures or pipelines after disinfection, with a Cl<sub>2</sub> residue of 2 mg/l or greater, shall be treated with a de-chlorination solution, in a method approved by the Engineer, prior to discharge.

### 3.4 PROTECTION OF LAND RESOURCES

- A. Land resources within the project boundaries and outside the limits of permanent work shall be restored to a condition, after completion of construction, that will appear to be natural and not detract from the appearance of the project. Confine all construction activities to areas shown on the Drawings.
- B. Outside of areas requiring earthwork for the construction of the new facilities, the Contractor shall not deface, injure, or destroy trees or shrubs, nor remove or cut them without prior approval. No ropes, cables, or guys shall be fastened to or attached to any

#### ENVIRONMENTAL PROTECTION MEASURES

01110-5

existing nearby trees for anchorage unless specifically authorized by the Engineer. Where such special emergency use is permitted, first wrap the trunk with a sufficient thickness of burlap or rags over which softwood cleats shall be tied before any rope, cable, or wire is placed. The Contractor shall in any event be responsible for any damage resulting from such use.

- C. Where trees may possibly be defaced, bruised, injured, or otherwise damaged by the Contractor's equipment, dumping or other operations, protect such trees by placing boards, planks, or poles around them. Monuments and markers shall be protected similarly before beginning operations near them.
- D. Any trees or other landscape feature scarred or damaged by the Contractor's equipment or operations shall be restored as nearly as possible to its original condition. The Engineer will decide what method of restoration shall be used and whether damaged trees shall be treated and healed or removed and disposed of.
- E. All scars made on trees by equipment, construction operations, or by the removal of limbs larger than 1-in in diameter shall be coated as soon as possible with an approved tree wound dressing. All trimming or pruning shall be performed in an approved manner by experienced workmen with saws or pruning shears. Tree trimming with axes will not be permitted.
- F. Climbing ropes shall be used where necessary for safety. Trees that are to remain, either within or outside established clearing limits, that are subsequently damaged by the Contractor and are beyond saving in the opinion of the Engineer, shall be immediately removed and replaced.
- G. The locations of the Contractor's storage, and other construction buildings, required temporarily in the performance of the work, shall be cleared portions of the job site or areas to be cleared as shown on the Drawings and shall require written approval of the Engineer and shall not be within wetlands or floodplains. The preservation of the landscape shall be an imperative consideration in the selection of all sites and in the construction of buildings. Drawings showing storage facilities shall be submitted for approval of the Engineer.
- H. If the Contractor proposes to construct temporary roads or embankments and excavations for plant and/or work areas, he/she shall submit the following for approval at least ten days prior to scheduled start of such temporary work.
  - 1. A layout of all temporary roads, excavations and embankments to be constructed within the work area.
  - 2. Details of temporary road construction.
  - 3. Drawings and cross sections of proposed embankments and their foundations, including a description of proposed materials.
  - 4. A landscaping drawing showing the proposed restoration of the area.

#### ENVIRONMENTAL PROTECTION MEASURES

01110-6

Removal of any trees and shrubs outside the limits of existing clearing area shall be indicated. The drawing shall also indicate location of required guard posts or barriers required to control vehicular traffic passing close to trees and shrubs to be maintained undamaged. The drawing shall provide for the obliteration of construction scars as such and shall provide for a natural appearing final condition of the area. Modification of the Contractor's approved drawings shall be made only with the written approval of the Engineer. No unauthorized road construction, excavation or embankment construction including disposal areas will be permitted.

- I. Remove all signs of temporary construction facilities such as haul roads, work areas, structures, foundations of temporary structures, stockpiles of excess of waste materials, or any other vestiges of construction as directed by the Engineer. It is anticipated that excavation, filling and plowing of roadways will be required to restore the area to near natural conditions which will permit the growth of vegetation thereon. The disturbed areas shall be prepared and seeded as approved by the Engineer.
- J. All debris and excess material will be disposed of outside wetland or floodplain areas in an environmentally sound manner.

### 3.5 PROTECTION OF AIR QUALITY

- A. Burning. The use of burning at the project site for the disposal of refuse and debris will not be permitted.
- B. Dust Control. The Contractor will be required to maintain all excavations, embankment, stockpiles, access roads, plant sites, waste areas, borrow areas, and all other work areas within or without the project boundaries free from dust which could cause the standards for air pollution to be exceeded, and which would cause a hazard or nuisance to others.
- C. An approved method of stabilization consisting of sprinkling or other similar methods will be permitted to control dust. The use of petroleum products is prohibited. The use of chlorides may be permitted with approval from the Engineer.
- D. Sprinkling, to be approved, must be repeated at such intervals as to keep all parts of the disturbed area at least damp at all times, and the Contractor must have sufficient competent equipment on the job to accomplish this if sprinkling is used. Dust control shall be performed as the work proceeds and whenever a dust nuisance or hazard occurs, as determined by the Engineer.

### 3.6 MAINTENANCE OF POLLUTION CONTROL FACILITIES DURING CONSTRUCTION

- A. During the life of this Contract, maintain all facilities constructed for pollution control as long as the operations creating the particular pollutant are being carried out or until the material concerned has become stabilized to the extent that pollution is no longer being created.

## ENVIRONMENTAL PROTECTION MEASURES

01110-7

3.7 NOISE CONTROL

- A. The Contractor shall make every effort to minimize noises caused by his/her operations. Equipment shall be equipped with silencers or mufflers designed to operate with the least possible noise in compliance with State and Federal regulations.

END OF SECTION 01110

ENVIRONMENTAL PROTECTION MEASURES

01110-8

Sump Pump Amnesty Program  
Contract 2- Areas 5B, 5D and 15  
Waltham, Massachusetts



## SECTION 01170

### SPECIAL PROVISIONS

#### PART 1-GENERAL

##### 1.1 GENERAL OBLIGATIONS OF THE CONTRACTOR

- A. General obligations of the Contractor shall be as set forth in the Contract Documents. Unless special payment is specifically provided in the payment paragraphs of the specifications, all incidental work and expense in connection with the completion of work under the Contract will be considered a subsidiary obligation of the Contractor and all such costs shall be included in the appropriate items in the Bid Form in connection with which the costs are incurred.

##### 1.2 SITE INVESTIGATION

- A. The Contractor shall satisfy himself/herself as to the conditions existing within the project area, the type of equipment required to perform the work, the character, quality and quantity of the subsurface materials to be encountered insofar as this information is reasonably ascertainable from an inspection of the site, as well as from information presented by the Drawings and Specifications. Any failure of the Contractor to acquaint himself/herself with the available information will not relieve him/her from the responsibility for estimating properly the difficulty or cost of successfully performing the work. The Owner assumes no responsibility for any conclusions or interpretation made by the Contractor on the basis of the information made available by the Owner.

##### 1.3 CONTRACTOR'S EMERGENCY CONTACT AND RESPONSE REQUIREMENT

- A. The Contractor will be required to designate a contact person as well as an emergency response crew who can be notified by the City of Waltham and the Engineer during Contract related emergencies, 7 days a week, 24 hours a day throughout the length of this Contract.
- B. The name of the designated person, a daytime contact telephone number, an evening contact telephone number, and a portable cellular telephone number must be furnished to the City of Waltham at the pre-construction meeting. In addition, the contact person will be required to carry a City of Waltham approved paging device (beeper) at all times during the Contract. The beeper number shall also be supplied at the pre construction meeting. The Contractor must also provide a mobile cellular telephone that will remain at the construction site during the hours of construction. The phone will be in a location that will allow the Contractor to respond to calls as well as the Owner or Engineer.
- C. The contact person shall be required to respond to any City of Waltham notification in this regard within one hour of such notice by calling (781) 314-3844 upon being

advised by the City of Waltham of the location and nature of the emergency, the Contractor will be required to provide an emergency coordinator or contact at the site within one hour of the initial notification and to mobilize the necessary response crew(s) and have them at the site of the emergency within two hours of the initial notification.

- D. The Contractor's failure to comply with the above notification and response requirements shall result in a five-hundred dollar (\$500.00) fine for each failure to respond as indicted in 1.3.C. In addition the Contractor shall be liable for any and all damages, liabilities and costs which result from his/her failure to respond to any emergency within the designated time periods. The City of Waltham assumes no responsibility or costs for the Contractor's negligence in complying with these requirements. If the subject fine or other liabilities are not paid by the Contractor upon request, it shall be deducted from any payment(s) which may be due the Contractor by the City of Waltham, solely at the discretion of the City of Waltham.
- E. The Contractor shall not use any City of Waltham personnel to fulfill these requirements.
- F. This requirement shall be considered an incidental part of the Contract, no matter how many times the Contractor is alerted during this Contract, and no payment will be made for any costs incurred or associated with the emergency contact and response requirements.

#### 1.4 PUBLIC UTILITIES

- A. The Contractor shall comply with the requirements of the Commonwealth of Massachusetts Statute - Chapter 82, Section 40, for excavations in public and private property. Compliance shall include the following:
  - 1. The Contractor shall notify public utility companies in writing at least 72 hours (excluding Saturdays, Sundays and legal holidays) but not more than 30 days before excavating in areas where underground utility plant (pipes, cables, manholes, etc) exist.
  - 2. The Contractor shall be responsible for providing the Utility Companies with a schedule of his/her activities in areas where the utilities exist.
  - 3. The Contractor shall immediately notify utility companies of any damage to their utilities resulting from construction operations.
  - 4. The express approval of the Owner shall be obtained before public water is used. Hydrants shall only be operated under the supervision of the Owner's personnel. The water is to be metered. A meter must be attained by the Water Division. The Contractor will be responsible for all associated fees and charges for water use.
- B. The Contractor shall notify DIGSAFE at 1-800-322-4844 at least 72 hours before digging, trenching, blasting, demolishing, boring, backfilling, grading, landscaping or other earth moving operations in any public ways, rights of way and easements.

## 1.5 PERMITS

- A. The Contractor shall be required to obtain all necessary permits for proper execution of certain phases of the project. The Contractor shall fill out all forms and furnish all drawings required to obtain the permits. A copy of the approved permit shall be submitted to the Engineer. All fees associated with these permits shall be paid by the Contractor as part of the project. Work shall not commence on any phase of the work requiring a permit until the permit is obtained.
- B. The Contractor shall obtain the required street opening permit from the Department of Public Works for excavations within the street or sidewalk area.
- C. The City received a negative determination of applicability (RDA) from the City of Waltham Conservation Commission for the following eight (8) properties with conditions: 43 Chesterbrook Road, 598 Lexington Street, 53 Lakeview Terrace, 59 Lakeview Terrace, 60 Lakeview Terrace, 69 Lakeview Terrace, 75 Lakeview Terrace and 26 Shore Road. A copy of the determination and conditions is included in Appendix G: City of Waltham Conservation Commission Requirements. The Contractor shall complete work at these properties and comply with the conditions: 1. Restore properties in buffer zone to condition that they were prior to work. 2. Reasonable precautions to prevent erosion. 3. Use straw wattles. 4. No use of phosphorus.

## 1.6 TRAFFIC AT STREET INTERSECTIONS

- A. The Contractor shall minimize interferences with the normal flow of traffic. The Contractor shall take all actions ordered by the Engineer to minimize the disruption of normal traffic flow.

## 1.7 STREET OPENING RESTRICTIONS

- A. The Contractor is made aware that all work within the streets including paving must cease by November 15 for the winter snow plowing. The Contractor shall schedule his work in accordance with this requirement.

## 1.8 Coordination with Property Owners

- A. The Contractor is made aware that coordination with the private property owners for entry and schedule for completing the work inside and outside of the private properties will be critical to timely completion of the work. The City will notify the property owners of the proposed work and overall schedule; however, the Contractor must coordinate with the Engineer to schedule work at each property. The Contractor must anticipate costs associated with coordination with the property owners and include them in each bid item. There will be no additional payment to the Contractor for any delays with scheduling the work with the property owners beyond his bid price.
- B. The City will notify each property owner of the proposed piping layout inside and outside of the building. The proposed piping layout has been developed based on field inspections and discussions with the property owners when feasible. The Contractor shall review and get

approval of the Engineer and the property owner of any variances from the proposed piping layout due to conditions discovered at the sites. The Contractor shall anticipate variance in piping layout and include the costs in his bid item price. The Contractor shall minimize installation of piping within existing paved driveways and surfaces to the maximum extent possible when proposing variant piping layout than that shown on the drawings.

1.8 Infiltration Systems

- A. The Contractor shall install a standard 6-foot diameter concrete infiltration basin where called for on the Contract Drawings; however; this may not be feasible at all locations due to high groundwater elevations. The Contractor may submit equivalent pre-engineered shallow infiltration systems to the Engineer for approval. The submission will include the volume of storage calculations that is equivalent to that of a standard 6-foot diameter concrete infiltration basin. There will be no additional compensation to the Contractor for using an alternate infiltration system.

PART 2 -PRODUCTS (NOT USED)

PART 3- EXECUTION (NOT USED)

END OF SECTION 01170

## SECTION 01200

### PROJECT MEETINGS

#### PART 1-GENERAL

##### 1.1 RELATED DOCUMENTS

- A. Drawings and general provisions of the Contract, including General and Supplementary Conditions and other Division 1 Specification Sections, apply to this section.

##### 1.2 COORDINATION WITH THE CITY

- A. As part of this Contract, the Contractor shall coordinate his activities with the City. In addition, the Contractor will give the City significant notice on any work that may be required to meet the contract schedule.

##### 1.3 PRECONSTRUCTION CONFERENCE

- A. A pre-construction conference will be held between the Contractor, the Engineer, the Owner, and applicable agency representatives to review the Contractor's proposed methods of complying with the requirements of the Contract Documents.
- B. Contractor will be notified of the time, date and place where the pre-construction conference will be held.

##### 1.4 PROGRESS MEETINGS WITH ENGINEER

- A. In addition to other regular project meetings for other purposes (as indicated elsewhere in the Contract Documents), hold general progress meetings twice each month with times coordinated with preparation of payment requests. Meeting dates shall be established by the Engineer. Require every entity then involved in the planning, coordination or performance of work to be properly represented at each meeting. Include (when applicable) consultants, separate contractors (if any), principal subcontractors, suppliers/manufacturers/fabricators, governing authorities, insurers, special supervisory personnel and others with an interest or expertise in the progress of the work. Review each entity's present and future needs including interface requirements, time, sequence, deliveries, access, site utilization, temporary facilities and services, hours of work, hazards and risks, housekeeping, submittals, change orders, and documentation of information for payment requests. Discuss whether each element of current work is ahead of schedule. Determine how behind-time work will be expedited, and secure commitments from the entities involved in doing so. Discuss whether schedule revisions are required to ensure that current and subsequent work will be completed within the Contract Time. Review everything of significance which could affect the progress of the work.

### PROJECT MEETINGS

01200-1

- B. Within seven days after each progress meeting date, the Engineer will forward copies of the minutes-of-the-meeting, to the Contractor.
- C. Immediately following each progress meeting where revisions to the Progress Schedule/Critical Path Schedule have been made or recognized (regardless of whether agreed to by each entity represented), revise the Schedule. Reissue revised Schedule within 10 days after meeting. At intervals matching the preparation of payment requests, revise and reissue the Schedule to show actual progress of the work in relation to the latest revision of the Schedule.

PART 2- PRODUCTS (NOT USED)

PART 3- EXECUTION (NOT USED)

END OF SECTION 01200

PROJECT MEETINGS  
01200-2

Sump Pump Amnesty Program  
Contract 2- Areas 5B, 5D and 15  
Waltham, Massachusetts

## SECTION 01300

### SUBMITTALS

#### PART 1- GENERAL

##### 1.1 DESCRIPTION OF REQUIREMENTS

- A. This Section specifies the general methods and requirements of submissions applicable to the following work-related submittals: Shop Drawings, Product Data, Samples, Construction Photographs, and Construction Schedules. Additional general submission requirements are contained in Paragraphs 6.24 and 6.25 of the General Conditions. Detailed submittal requirements will be specified in the technical specifications sections.
- B. All submittals shall be clearly identified by reference to Specification Section, Paragraph, Drawing No. or Detail as applicable. Submittals shall be clear and legible and of sufficient size for sufficient presentation of data.

##### 1.2 SHOP DRAWINGS PRODUCT DATA, SAMPLES

###### A. Shop Drawings

- 1. Shop drawings, as defined in the General Conditions, and as specified in individual work Sections include, but are not necessarily limited to, custom-prepared data such as fabrication and erection/installation (working) scheduled information, setting diagrams, actual shopwork manufacturing instructions, custom templates, special. wiring diagrams, coordination drawings, individual system or equipment inspection and test reports including performance curves and certifications, as applicable to the Work.
- 2. All shop drawings submitted by subcontractors for approval shall be sent directly to the Contractor for checking. The Contractor shall be responsible for their submission at the proper time so as to prevent delays in delivery of materials.
- 3. The Contractor shall check all subcontractor's shop drawings regarding measurements, size of members, materials, and details to satisfy himself that they conform to the intent of the Drawings and Specifications. Shop drawings found to be inaccurate or otherwise in error shall be returned to the subcontractors for correction before submission thereof.
- 4. All details on shop drawings submitted for approval shall show clearly the relation of the various parts to the main members and lines of the structure, and where correct fabrication of the work depends upon field measurements, such measurements shall be made and noted on the drawings before being submitted for approval.

### SUBMITTALS

01300-1

5. Submittals for equipment specified under Division 2 shall include a listing of all installations where identical or similar equipment has been installed and been in operation for a period of at least one year.

B. Product Data

1. Product data as specified in individual Sections, include, but are not necessarily limited to, standard prepared data for manufactured products (sometimes referred to as catalog data), such as the manufacturer's product specification and installation instructions, availability of colors and patterns, manufacturer's printed statements of compliance's and applicability, roughing in diagrams and templates, catalog cuts, product photographs, standard wiring diagrams, printed performance curves and operational-range diagrams, production or quality control inspection and test reports and certifications, mill reports, product operating and maintenance instructions and recommended spare-parts listing and printed product warranties, as applicable to the Work.

C. Samples

1. Samples specified in individual Sections, include, but are not necessarily limited to, physical examples of the work such as sections of manufactured or fabricated work, small cuts or containers of materials, complete units of repetitively-used products, color/texture/pattern swatches and range sets, specimens for coordination of visual effect, graphic symbols and units of work to be used by the Engineer or Owner for independent inspection and testing, as applicable to the Work.

### 1.3 CONTRACTOR'S RESPONSIBILITIES

- A. The Contractor shall review shop drawings, product data and samples, including those by subcontractors, prior to submission to determine and verify the following:
  1. Field measurements
  2. Field construction criteria
  3. Catalog numbers and similar data
  4. Conformance with the Specifications
- B. Each shop drawing, sample and product data submitted by the Contractor shall have affixed to it the following Certification Statement including the Contractor's Company name and signed by the Contractor: "Certification Statement: by this

submittal, I hereby represent that I have determined and verified all field measurements, field construction criteria, materials, dimensions, catalog numbers and similar data and I have checked and coordinated each item with other applicable approved shop drawings

### SUBMITTALS 01300-2



and all Contract requirements." Shop drawings and product data sheets 11-in x 17-in and smaller shall be bound together in an orderly fashion and bear the above Certification Statement on the cover sheet. The cover sheet shall fully describe the packaged data and include a listing of all items within the package. Provide to the Resident Project Representative a copy of each submittal transmittal sheet for shop drawings, product data and samples at the time of submittal of said drawings, product data and samples to the Engineer.

- C. The review and approval of shop drawings, samples or product data by the Engineer shall not relieve the Contractor from his/her responsibility with regard to the fulfillment of the terms of the Contract. All risks of error and omission are assumed by the Contractor and the Engineer will have no responsibility therefor.
- D. No portion of the work requiring a shop drawing, sample, or product data shall be started nor shall any materials be fabricated or installed prior to the approval or qualified approval of such item. Fabrication performed, materials purchased or on- site construction accomplished which does not conform to approved shop drawings and data shall be at the Contractor's risk. The Owner will not be liable for any expense or delay due to corrections or remedies required to accomplish conformity.
- E. Project work, materials, fabrication, and installation shall conform with approved shop drawings, applicable samples, and product data.

#### 1.4 SUBMISSION REQUIREMENTS

- A. Make submittals promptly in accordance with approved schedule, and in such sequence as to cause no delay in the Work or in the work of any other contractor.
- B. Each submittal, appropriately coded, will be returned within 30 working days following receipt of submittal by the Engineer.
- C. Number of submittals required:
  - 1. Shop Drawings as defined in Paragraph 1.2 A: Six copies.
  - 2. Product Data as defined in Paragraph 1.2 B: Three copies.
  - 3. Samples: Submit the number stated in the respective Specification Sections.
- D. Submittals shall contain:
  - 1. The date of submission and the dates of any previous submissions.
  - 2. The Project title and number.
  - 3. Contractor identification.
  - 4. The names of:

#### SUBMITTALS 01300-3

- a. Contractor
  - b. Supplier
  - c. Manufacturer
5. Identification of the product, with the specification section number, page and paragraph(s).
  6. Field dimensions, clearly identified as such.
  7. Relation to adjacent or critical features of the Work or materials.
  8. Applicable standards, such as ASTM or Federal Specification numbers.
  9. Identification of deviations from Contract Documents.
  10. Identification of revisions on resubmittals.
  11. An 8-in x 3-in blank space for Contractor and Engineer stamps.

1.5 REVIEW OF SHOP DRAWINGS, PRODUCT DATA, WORKING DRAWINGS AND SAMPLES

- A. The review of shop drawings, data, and samples will be for general conformance with the design concept and Contract Documents. They shall not be construed:
  1. as permitting any departure from the Contract requirements;
  2. as relieving the Contractor of responsibility for any errors, including details, dimensions, and materials;
  3. as approving departures from details furnished by the Engineer, except as otherwise provided herein.
- B. The Contractor remains responsible for details and accuracy, for coordinating the work with all other associated work and trades, for selecting fabrication processes, for techniques of assembly, and for performing work in a safe manner.
- C. If the shop drawings, data or samples as submitted describe variations and show a departure from the Contract requirements which Engineer finds to be in the interest of the Owner and to be so minor as not to involve a change in Contract Price or time for performance, the Engineer may return the reviewed drawings without noting an exception.
- D. Submittals will be returned to the Contractor under one of the following codes.

SUBMITTALS  
01300-4

- Code 1 - "NO EXCEPTION TAKEN" is assigned when there are no notations or comments on the submittal. When returned under this code the Contractor may release the equipment and/or material for manufacture.
- Code 2 - "MAKE CORRECTIONS AS NOTED". This code is assigned when a confirmation of the notations and comments IS NOT required by the Contractor. The Contractor may release the equipment or material for manufacture; however, all notations and comments must be incorporated into the final product.
- Code 3 - "SUBMIT SPECIFIED ITEM". This combination of codes is assigned when a confirmation of the notations and comments IS required by the Contractor. This confirmation shall specifically address each omission and nonconforming item that was noted. Confirmation is to be received by the Engineer within 10 calendar days of the date of the Engineer's transmittal requiring the confirmation.
- Code 4 - "REVISE AND RESUBMIT". This combination of codes is assigned when notations and comments are extensive enough to require a resubmittal of the package. This resubmittal is to address all comments, omissions and nonconforming items that were noted. Resubmittal is to be received by the Engineer within 10 calendar days of the date of the Engineer's transmittal requiring the resubmittal.
- Code 5 - "REJECTED" is assigned when the submittal does not meet the intent of the Contract Documents. The Contractor must resubmit the entire package revised to bring the submittal into conformance. It may be necessary to resubmit using a different manufacturer/vendor to meet the Contract Documents.
- E. Resubmittals will be handled in the same manner as first submittals. On resubmittals the Contractor shall direct specific attention, in writing on the letter of transmittal and on resubmitted shop drawings by use of revision triangles or other similar methods, to revisions other than the corrections requested by the Engineer, on previous submissions. Any such revisions which are not clearly identified shall be made at the risk of the Contractor. The Contractor shall make corrections to any work done because of this type revision that is not in accordance to the Contract Documents as may be required by the Engineer.
- F. Partial submittals may not be reviewed. The Engineer will be the only judge as to the completeness of a submittal. Submittals not complete will be returned to the Contractor, and will be considered "Rejected" until resubmitted. The Engineer may at his/her option provide a list or mark the submittal directing the Contractor to the areas that are incomplete.
- G. If the Contractor considers any correction indicated on the shop drawings to constitute a change to the Contract Documents, the Contractor shall give written notice thereof to the Engineer at least seven working days prior to release for manufacture.

## SUBMITTALS 01300-5

- H. When the shop drawings have been completed to the satisfaction of the Engineer, the Contractor shall carry out the construction in accordance therewith and shall make no further changes therein except upon written instructions from the Engineer.

## 1.6 DISTRIBUTION

- A. Distribute reproductions of approved shop drawings and copies of approved product data and samples, where required, to the job site file and elsewhere as directed by the Engineer. Number of copies shall be as directed by the Engineer but shall not exceed 6.

## 1.7 CONSTRUCTION PHOTOGRAPHS

- A. Where directed by the Engineer, the Contractor shall have an average of 20 color photographs per month made of the work during its progress and 20 color photographs of the completed facilities. The photographs shall be of such views and taken at such times as the Engineer directs. Photographs shall be taken at each property.
- B. All photographic work shall be done by a qualified, established commercial photographer acceptable to the Engineer. Three prints of each photograph shall be furnished promptly to the Engineer, and each print shall have a glossy finish and be mounted in plastic sleeving on a substantial backing. The overall dimensions of each mounted print shall be 8 x 10-in with 1-1/4-in flexible binding margin on the long top side to permit storage in standard 3-ring binders.
- C. The film negatives shall be retained in the files of the photographer until the completion of the project and shall then be turned over to the Owner.
- D. Each photograph shall have attached to the backing a paper label, approximately 2-1/4-in wide by 1-3/4-in high containing thereon in neat lettering;
  - 1. Contractor's name
  - 2. Short Description of View
  - 3. Photo No. and
  - 4. Photographer's Firm Name

## 1.8 SCHEDULES

- A. Provide all schedules required by Articles 2.6, 2.9, 14.1, and elsewhere in the General Conditions.
- B. The Contractor shall submit a progress schedule before starting any work, in accordance with Article 2.6 of the General Conditions. The Contractor shall review the progress schedule with the Engineer periodically. Such review shall be made on a monthly basis or

## SUBMITTALS 01300-6

more frequently as required by the Engineer. The progress schedule shall be updated as required by the Engineer.

1.9 "OR EQUAL"

- A. Should the Contractor seek approval of a product other than the brand or brands named in these specifications, it shall furnish written evidence that such product conforms in all respects to the specified requirements, and that it has been used successfully elsewhere under similar conditions. Where the specified requirements involve conformance to recognized codes or standards the Contractor shall furnish evidence of such conformance in the form of test or inspection reports, prepared by a recognized agency, and bearing an authorized signature.
- B. Manufacturers' standard data and catalog cut sheets will not be considered sufficient in themselves, and the Engineer will not be responsible for seeking further data from the manufacturer, or for otherwise researching the product. Failure to provide complete data will be cause for rejection of the product.
- C. The Contractor shall be responsible for all additional costs including license fees, foundation, piping and electrical work necessary to accommodate the proposed "or equal" equipment. Items which result in a cost reduction shall be presented and a change order reflecting 65% of the cost savings will be prepared and the contract price modified.

1.10 PROFESSIONAL ENGINEER (P.E.) CERTIFICATION FORM

- A. If specifically required in other Sections of these Specifications, the Contractor shall submit a P.E. Certification for each item required, in the form attached to this Section, completely filled in and stamped.

1.11 GENERAL PROCEDURES FOR SUBMITTALS

- A. Coordination of Submittal Times: Prepare and transmit each submittal sufficiently in advance of performing the related work or other applicable activities, or within the time specified in the individual work sections, of the Specifications, so that the installation will not be delayed by processing times including disapproval and resubmittal (if required), coordination with other submittals, testing, purchasing, fabrication, delivery and similar sequenced activities. No extension of time will be authorized because of the Contractor's failure to transmit submittals sufficiently in advance of the Work.

PART 2- PRODUCTS (NOT USED)

PART 3- EXECUTION (NOT USED)

END OF SECTION 01300

SUBMITTALS  
01300-7

## SECTION 01400

### QUALITY ASSURANCE

#### PART 1 - GENERAL

##### 1.1 RELATED DOCUMENTS

- A. Drawings and general provisions of the Contract, including General and Supplementary Conditions and Division 1 Specification Sections, apply to this section.

##### 1.2 SUMMARY

- A. This section covers Quality Assurance and Control requirements for this contract.
- B. The Contractor is responsible for controlling the quality of work, including work of its subcontractors, (filed sub-bidders) and suppliers and for assuring the quality specified in the Technical Specifications is achieved.
- C. Refer to the Article 6 - Contractor's Responsibilities, paragraphs 6.01 6.02, 6.03, of the GENERAL CONDITIONS.

##### 1.3 TESTING LABORATORY SERVICES

- A. All tests which require the services of a laboratory to determine compliance with the Contract Documents, shall be performed by an independent commercial testing laboratory acceptable to the Engineer. The laboratory must be certified by the Commonwealth of Massachusetts for the parameters tested and required under the project. The laboratory shall be staffed with experienced technicians, properly equipped, and fully qualified to perform the tests in accordance with the specified standards.
- B. Preliminary Testing Services: Unless otherwise specified, the Contractor shall be responsible for all testing laboratory services in connection with concrete materials and mix designs, the design of asphalt mixtures, gradation tests for structural and embankment fills, backfill materials, and all other tests and engineering data required for the Engineer's review of materials and equipment proposed to be used in the Work. The Contractor shall obtain the Engineer's acceptance of the testing laboratory before having services performed, and shall pay all costs for services.
- C. Quality Control Testing Services: Perform all quality control tests in the field or in the laboratory on concrete, asphalt mixtures, moisture density (Proctor) gradation tests on structural and embankment fills, and backfill materials, in-place field density tests on structural and embankment fills, and other materials and equipment, during and after their incorporation in the Work. Field sampling and testing shall be performed in the general manner indicated in the specifications, with minimum interference with construction operations. The Engineer shall determine the exact time and location of field sampling and testing, and may require such additional sampling and

### QUALITY ASSURANCE

01400-1

testing as necessary to determine that materials and equipment conform with data previously furnished by Contractor and with the Contract Documents.

- D. Arrangements for delivery of samples and test specimens to the testing laboratory will be made by the Contractor. The laboratory tests shall be performed within a reasonable time consistent with the specified standards. Furnish a written report of each test to the Engineer.
- E. Contractor shall furnish all sample materials and cooperate in the sampling and field testing activities, interrupting the Work when necessary. When sampling or testing activities are performed in the field, the Contractor shall furnish personnel and facilities to assist in the activities.
- F. The Contractor shall not retain any testing laboratory against which the Owner or the Engineer have reasonable objection, and if at any time during the construction process the services become unacceptable to the Owner, or the Engineer, either the Owner or the Engineer may direct in writing that such services be terminated. The request must be supported with evidence of improper testing or unreasonable delay. If the Engineer determines that sufficient cause exists, the Contractor shall terminate the services and engage a different testing laboratory.
- G. Transmittal of Test Reports: Written reports of testing and engineering data furnished by the Contractor for the Engineer's review of materials and equipment proposed to be used in the Work shall be submitted as specified for Shop Drawings.
- H. The testing laboratory shall furnish four copies of a written report of each test performed by laboratory personnel in the field or laboratory to the Contractor. Distribution shall be two copies of each test report to the Engineer's Representative, one copy to the Owner, and one copy for the Contractor within three days after each test is completed.

#### 1.4 QUALITY ASSURANCE

- A. Codes and Standards: Refer to Article 3 .. Contract Documents, Intent, Amending, Reuse, paragraph 3.3 of the General Conditions.

Copies of applicable referenced standards are not included in the Contract Documents. Where copies of standards needed by the Contractor for Superintendence and quality control of the work, the Contractor shall obtain a copy or copies directly from the publication source and maintain at the jobsite, available to the Contractor's personnel, subcontractors, and Engineer.

- B. Quality of Materials: Unless otherwise specified, all materials and equipment furnished for permanent installation in the Work shall conform to applicable standards and specifications and shall be new, unused, and free from defects and imperfections, when installed or otherwise incorporated in the Work. Material and equipment shall not be used by the Contractor for any purpose other than that intended or specified unless such use is authorized by the Engineer.

#### QUALITY ASSURANCE

01400-2

- C. Where so specified, products or workmanship shall also conform to the additional performance requirements included within the Contract Documents to establish a higher or more stringent standard or quality than that required by the referenced standard.

#### 1.5 OFFSITE INSPECTION

- A. When the specifications require inspection of materials or equipment during the production, manufacturing, or fabricating process, or before shipment, such services shall be performed by an independent testing laboratory, or inspection organization acceptable to Engineer in conjunction with or by the Engineer.
- B. The Contractor shall give appropriate written notice to the Engineer not less than 30 days before offsite inspection services are required, and shall provide for the producer, manufacturer, or fabricator to furnish safe access and proper facilities and to cooperate with inspecting personnel in the performance of their duties.
- C. The inspection organization shall submit a written report to the Contractor who shall provide copies to the Engineer.

#### 1.6 MATERIALS AND EQUIPMENT

- A. The Contractor shall maintain control over procurement sources to ensure that materials and equipment conform to specified requirements in the Contract Documents.
- B. The Contractor shall comply with manufacturer's printed instructions regarding all facets of materials and/or equipment movement, storage, installation, testing, startup, and operation. Should circumstances occur where the contract documents are more stringent than the manufacturer's printed instructions, the Contractor shall comply with the specifications. In cases where the manufacturer's printed instructions are more stringent than the contract documents, the Contractor shall advise the Engineer of the disparity and conform to the manufacturer's printed instructions. In either case, the Contractor is to apply the more stringent specification or recommendation, unless approved otherwise by the Engineer.

#### 1.7 SHOP AND FIELD TESTING

- A. The Contractor is also responsible for providing the shop and field testing specified in the technical specifications sections.
- B. The Contractor and its Subcontractor shall perform inspections, tests, and other services as required by the Contract Documents.
- C. Contractor shall provide twenty one days notice to the Engineer so that the Engineer may witness Contractor and for Subcontractors off site and on site tests. The Engineer's witnessing of tests does not relieve the Contractor and/or Subcontractors of their obligation to comply with the requirements of the Contract Documents.

### QUALITY ASSURANCE

01400-3



## 1.8 MANUFACTURER'S FIELD SERVICES

- A. When specified in the technical specifications sections, the Contractor shall arrange for and provide technical representation from manufacturers of respective equipment, items or components. The manufacturer's representative shall be a factory trained service engineer/technician with the type and length of experience specified in the technical specifications.
- B. **Services Furnished Under This Contract:** An experienced, competent, and authorized factory trained service engineer/technician representative of the manufacturer of each item of equipment for which field services are indicated in the specifications shall visit the site of the Work and inspect, operate, test, check, adjust if necessary, and approve the equipment installation. In each case, the manufacturer's service representative shall be present when the equipment is placed in operation. The manufacturer's service representative shall revisit the jobsite as often as necessary until all problems are corrected and the equipment installation and operation are satisfactory to the Engineer.

## 1.9 CERTIFICATION FORMS AND CERTIFICATES

- A. The Contractor shall be responsible for submitting the certification forms and certificates in conformance with the requirements specified in Section 01300 - Submittals.

## PART 2 -PRODUCTS (NOT USED)

## PART 3- EXECUTION

### 3.1 QUALITY CONTROL

- A. Quality control is the responsibility of the Contractor, and the Contractor shall maintain control over construction and installation processes to assure compliance with specified requirements.
- B. Certifications for personnel) procedures, and equipment associated with special processes (e.g., welding, cable splicing, instrument calibration, surveying) shall be maintained in the Contractor's field office, available for inspection by the Engineer. Copies will made available to the Engineer upon request.
- C. Means and methods of construction and installation processes are the responsibility of the Contractor, and at no time is it the intent of the Engineer or Owner to supersede or void that responsibility.

END OF SECTION 01400

## QUALITY ASSURANCE

01400-4

SECTION 01576

POLICING

PART 1- GENERAL

1.1 SUMMARY

- A. This project will require the services of police detailing. The Contractor will make all the arrangements with the Police Department to schedule such detailing during all construction hours. An allowance has been built into the pricing sheet for the Police detailing.
- B. The Contractor will provide separate and detailed copies of the Police Service Payments to the City on a weekly basis.
- C. The intent is to insure public safety by police direction of traffic. Police are not to serve as watchmen to protect the Contractor's equipment and materials, or to warn pedestrians of such hazards as open trenches.
- D. Nothing contained herein shall be construed as relieving the Contractor of any of his responsibilities for protection of persons and property under the terms of the Contract.

END OF SECTION 01576

POLICING  
01576-1

## SECTION 01601

### CONTROL OF MATERIALS

#### PART 1 - GENERAL

##### 1.1 RELATED DOCUMENTS

- A. Drawings and general provisions of the Contract, including General and Supplementary Conditions and the following other Division 1 Specification Sections:

Section 01024 Measurement and Payment  
Section 01046 Control of Work  
Section 01300 Submittals  
Section 01400 Quality Assurance

##### 1.2 SUMMMARY

- A. This section specifies the general requirements for the delivery, handling, storage and protection for all items required in the construction of the work. Specific requirements, if any, are specified with the related item.

##### 1.3 APPROVAL OF MATERIALS

- A. Unless otherwise specified, only new materials and equipment shall be incorporated in the work. All materials and equipment furnished by the Contractor shall be subject to the inspection and approval of the Engineer. No material shall be delivered to the work without prior approval of the Engineer.
- B. As specified in Section 01300, the Contractor shall submit to the Engineer, data relating to materials and equipment he proposes to furnish for the work. Such data shall be in sufficient detail to enable the Engineer to identify the particular product and to form an opinion as to its conformity to the specifications.
- C. Facilities and labor for handling and inspection of all materials and equipment shall be furnished by the Contractor. If the Engineer requires, either prior to beginning or during the progress of the work, the Contractor shall submit additional samples or materials for such special tests as may be necessary to demonstrate that they conform to the specifications. Such samples shall be furnished, stored, packed, and shipped as directed at the Contractor's expense. Except as otherwise noted, the Owner will make arrangements for and pay for the tests.
- D. Any delay of approval resulting from the Contractor's failure to submit samples or data promptly shall not be used at basis of a claim against the Owner or the Engineer.

### CONTROL OF MATERIALS

01601-1

- E. In order to demonstrate the proficiency of workmen or to facilitate the choice among several textures, types, finishes, and surfaces, the Contractor shall provide such samples of workmanship or finish as may be required.
- F. The materials and equipment used on the work shall correspond to the approved samples or other data.

#### 1.4 TRANSPORTATION AND DELIVERY

- A. Transport and handle items in accordance with manufacturer's printed instructions.
- B. Schedule delivery to reduce long term on-site storage prior to installation and/or operation. Under no circumstances shall equipment be delivered to the site more than one month prior to installation without written authorization from the Engineer.
- C. Coordinate delivery with installation to ensure minimum holding time for items that are hazardous, flammable, easily damaged or sensitive to deterioration.
- D. Deliver products to the site in manufacturer's original sealed containers or other packing systems, complete with instructions for handling, storing, unpacking, protecting and installing.
- E. All items delivered to the site shall be unloaded and placed in a manner which will not hamper the Contractor's normal construction operation or those of subcontractors and other contractors and will not interfere with the flow of necessary traffic.
- F. Provide equipment and personnel to unload all items delivered to the site.
- G. Promptly inspect shipment to assure that products comply with requirements, quantities are correct, and items are undamaged. For items furnished by others (i.e. Owner, other Contractors), perform inspection in the presence of the Engineer. Notify Engineer verbally, and in writing, of any problems.

#### 1.5 HANDLING, STORAGE, AND PROTECTION OF MATERIALS

- A. All materials and equipment to be incorporated in the work shall be handled and stored by the manufacturer, fabricator, supplier and Contractor before, during and after shipment in a manner to prevent warping, twisting, bending, breaking, chipping, rusting and any injury, theft or damage of any kind whatsoever to the material or equipment.
- B. All pipe and other materials delivered to the job shall be unloaded and placed in a manner which will not hamper the normal operation of existing facilities or interfere with the flow of necessary traffic.
- C. Only the materials and equipment required for the days operations will be allowed to stand within the limits of the rights-of-ways. All else shall be removed and stored by

### CONTROL OF MATERIALS

01601-2

the Contractor at a private off-site location to be acquired by the Contractor) or an agreed upon staging area arranged and approved by the Owner.

- D. Store and protect products in accordance with the manufacturer's printed instructions, with seals and labels intact and legible. Storage instruction shall be studied by the Contractor and reviewed with the Engineer by him. Instructions shall be carefully followed and a written record of this kept by the Contractor. Arrange storage to permit access for inspection.
- E. Store loose granular materials on solid flat surface in a well-drained area. Prevent mixing with foreign matter. Provide environmental protection measures as specified in Section 01110.
- F. Cement and lime shall be stored under a roof and off the ground and shall be kept completely dry at all times. All structural, miscellaneous and reinforcing steel shall be stored off the ground or otherwise to prevent accumulation of dirt or grease, and in a position to prevent accumulations of standing water and to minimize rusting. Beams shall be stored with the webs vertical. Precast concrete shall be handled and stored in a manner to prevent accumulations of dirt, standing water, staining, chipping or cracking. Brick, block and similar masonry products shall be handled and stored in manner to reduce breakage, cracking and spalling to a minimum.
- G. All mechanical and electrical equipment and instruments subject to corrosive damage by the atmosphere (even though covered by canvas) shall be stored in a weathertight building to prevent injury. The building may be a temporary structure on the site or elsewhere, but it must be satisfactory to the Engineer. Building shall be provided with ventilation to prevent condensation. Maintain temperature and humidity within range required by manufacturer.
- H. All equipment shall be stored fully lubricated with oil, grease and other lubricants unless otherwise instructed by the manufacturer.
- I. Moving parts shall be rotated a minimum of once weekly to insure proper lubrication and to avoid metal-to-metal. Upon installation of the equipment, the Contractor shall start the equipment, at least half load, once weekly for an adequate period of time to ensure that the equipment does not deteriorate from lack of use.
- J. Lubricants shall be changed upon completion of installation and as frequently as required thereafter during the period between installation and acceptance. New lubricants shall be put into the equipment at time of acceptance.
- K. Prior to acceptance of the equipment, the Contractor shall have the manufacturer inspect the equipment and certify that its condition has not been detrimentally affected by the long storage period. Such certifications by the manufacturer shall be deemed to mean that the equipment is judged by the manufacturer to be in a condition equal to that of equipment that has been shipped, installed, tested and accepted in a minimum time period. As such, the manufacturer will guaranty the .

## CONTROL OF MATERIALS

01601-3

equipment equally in both instances. If such a certification is not given, the equipment shall be judged to be defective. It shall be removed and replaced at the Contractor's expense.

- L. All materials which, in the opinion of the Engineer, have become so damaged as to be unfit for the use intended or specified shall be promptly removed from the site of the work and the Contractor shall receive no compensation for the damaged material or its removal

PART 2- PRODUCTS (NOT USED)

PART 3 EXECUTION (NOT USED)

END OF SECTION 01601

CONTROL OF MATERIALS  
01601-4

Sump Pump Amnesty Program  
Contract 2- Areas 5B, 5D and 15  
Waltham, Massachusetts

## SECTION 01700

### WORK ON PRIVATE PROPERTY AND SITE ACCESS

#### PART 1-GENERAL

##### 1.1 SUMMARY

- A. The Contractor shall perform all required construction work on private property. The Contractor shall take special care to preserve and restore private property to its original condition or better after work is completed.
- B. The Contractor shall coordinate site access to private property with the City of Waltham Engineering Department.

##### 1.2 EXTERIOR WORK ON PRIVATE PROPERTY

- A. The Contractor shall take all precautions necessary to minimize disturbance to retaining walls (stone, concrete block or other), shrubs, trees, mailboxes, lamp posts, etc. and all other features of the property. No cutting of trees or removal of shrubs will be allowed on private property unless directed otherwise by the Owner. The Contractor will be responsible for restoration of the property to a condition at least equal to that existing prior to construction.
- B. The Contractor shall minimize damage to existing landscape and yard features by properly handling and removing these items. Existing landscaping and other yard features shall be reinstalled whenever possible. Any damaged items or items deteriorated or for other reasons are unable to be reinstalled shall be replaced with items equal to or better than existing. All items to be replaced and/or reinstalled shall be approved by the Owner.
- C. If trees or shrubs which are not to be removed are damaged during construction to such degree as to affect their growth or diminish their beauty or usefulness, they shall be replaced at the Contractor's expense by items of kind and quality at least equal to that existing at the start of the work.
- D. Fences, walks, stone walls and other private property which might be damaged by the Contractor's operations shall be removed, and replaced at the Contractor's expense to a condition at least equal to that existing at the start of the work.
- E. Grass areas damaged by the Contractor's operations shall be loamed and hydroseeded as specified under applicable provisions of Section 02930 and shall be restored to a condition at least equal to or better than that existing prior to construction.
- F. All paved areas shall be repaired as specified in Section 02576 and all concrete sidewalk, walkway, driveway apron and driveway areas shall be repaired as specified in section 02515.

### WORK ON PRIVATE PROPERTY AND SITE ACCESS

01700-1

### 1.3 INTERIOR WORK ON PRIVATE PROPERTY

- A. The Contractor shall take all precautions to minimize disturbance to walls, floors, piping, hangers, columns, girders, personal belongings, etc. and other features existing inside existing basements and structures where the work will be performed. No private property shall be demolished or destroyed. The Contractor shall be responsible for restoration of property to a condition at least equal to that existing prior to construction.
- B. The Contractor shall minimize damage to existing basement features during execution of the work. Personal belongings in the way of the area of work shall be carefully moved aside to complete the work. If the Contractor is not comfortable moving personal belongings in the way of the Work, he shall coordinate with the Waltham Engineering Department to have the items moved by the property owner. Any damaged items shall be replaced with an item equal to or better than existing. All items replaced shall meet the approval of the Owner.
- C. Any walls damaged (scuffed, chipped, etc.) as a result of the Contractor's operations shall be repaired prior to completion of work.
- D. The Contractor shall protect existing private property and belongings along all paths of entrance and egress during the progress of work. Work areas and walkways used to enter and exit the building shall be cleaned and returned to the condition existing prior to construction.

### 1.4 SITE ACCESS

- A. Access to the site shall be coordinated by the Waltham Engineering Department (WED). The WED will obtain permission to access property through a separate agreement between the WED and the property owner. The WED will schedule an appointment with the property owner to execute the work. The Contractor shall not access private property until authorized by the WED.
- B. Upon completion of the construction, all traces of access shall be removed and all yard features and landscaping which existed prior to the start of the work shall be replaced or restored to their original condition.

### 1.5 RESTORING PRIVATE PROPERTY AND RIGHTS-OF-WAY

- A. The Contractor shall be responsible for all damage to private property due to his operations. He shall protect from injury, all walls, fences, cultivated shrubbery and vegetables, fruit trees, pavement, underground facilities, such as water pipe, or other utilities which may be encountered along the pipe route. If removal and replacement are required, it shall be done in a workmanlike manner so that replacement is equivalent to that which existed prior to construction.
- B. Existing trees, shrubs, plants and bushes shall be fully protected as specified. The work shall also include removing and replacing trees, shrubs and bushes as required.

#### WORK ON PRIVATE PROPERTY AND SITE ACCESS



It shall include the careful excavation of the root ball which shall be wrapped with burlap while out of the ground. The Contractor shall replant them after backfilling the trench, stake them in an upright position, and shall periodically water replanted trees, bushes and shrubs. The Contractor shall be fully responsible for ensuring that any and all trees, bushes and shrubs removed and replanted "take" and return to a viable state. Any replanted item that fails to "take" or that is so damaged as to be unsuitable for replanting shall be replaced by the Contractor, at no additional cost to the Owner, with a tree, bush, or shrub equal to the one removed. New or replacement trees, bushes or shrubs shall be installed in accordance with Section 02950.

- C. The Owner will inspect all work for provisional acceptance upon written request of the Contractor as specified in Section 02950.
- D. All plants shall be guaranteed by the Contractor as specified in Section 02950.
- E. The Contractor shall be responsible for all damage to private property and belongings inside existing basements and structures. The Contractor shall repair or replace damaged items to pre-construction conditions. The Contractor shall clean all areas where work took place or used to conduct work and leave areas in the condition existing prior to construction.

END OF SECTION 01700

WORK ON PRIVATE PROPERTY AND SITE ACCES

01700-3

Sump Pump Amnesty Program  
Contract 2- Areas 5B, 5D and 15  
Waltham, Massachusetts

## SECTION 01710

### CONTRACT CLOSEOUT

#### PART 1 GENERAL

##### 1.1 RELATED DOCUMENTS

- A. Drawings and general provisions of Contract, including General and Supplementary Conditions and other Division 1 Specification Sections, apply to this Section.

##### 1.2 SUMMARY

- A. This Section specifies administrative and procedural requirements for contract closeout, including, but not limited to:
  - 1. Inspection procedures.
  - 2. Project record document submittal.
  - 3. Final cleaning.
- B. Closeout requirements for specific construction activities are included in the appropriate Sections in Division 2.

##### 1.3 SUBSTANTIAL COMPLETION

- A. Preliminary Procedures: Before the Contractor requests inspection for Certification of Substantial Completion of the project, the Contractor shall complete the following items. Exceptions to the listed items will be noted in the request.
- B. In the Application for Payment that coincides with, or first follows, the date Substantial Completion is claimed, show 100 percent completion for the portion of the work claimed as substantially complete. Include supporting documents for completion, as indicated in these Contract Documents, and a statement showing an accounting of changes to the Contract Sum.
  - 1. If 100 percent completion cannot be shown, include a list of incomplete items, the value of incomplete construction, and reasons the work is not complete.
  - 2. Advise the Engineer and Owner of pending insurance change over requirements if applicable.
  - 3. Submit specific Warranties, Workmanship Bonds, Maintenance Agreements, Final Certifications, As-Built Plans, and similar documents.
- C. Complete final cleanup requirements.

### CONTRACT CLOSEOUT

01710-1

- D. Inspection Procedures: On receipt of a request for inspection, the Engineer will either proceed with inspection or advise the Contractor of unfulfilled requirements. The Engineer will prepare the Certificate of Substantial Completion following inspection, or advise the Contractor of construction that must be completed or corrected before the certificate will be issued.
1. The Engineer will repeat inspection when requested and assure that the work has been substantially completed.
  2. Results of the completed inspection will form the basis of requirements for final acceptance.

#### 1.4 FINAL ACCEPTANCE

- A. Preliminary Procedures: Before requesting final inspection for Certification of Final Acceptance and Final Payment, complete the following. List exceptions in the request.
1. Submit the Final Payment Request with releases and supporting documentation not previously submitted and accepted.
  2. Include Certificates of Insurance for Products and Completed Operations, where required.
  3. Submit an updated final statement, accounting for final additional changes to the contract sum, if any.
  4. Submit a certified copy of the Engineer's final inspection list of items to be completed or corrected, stating that each item has been completed or otherwise resolved for acceptance, and the list has been endorsed and dated by the Engineer. This will include acceptance by the Engineer of any seeded areas.
- B. Submit Consent of Surety to Final Payment.
1. Submit a final liquidated damages settlement statement, if applicable.
  2. Submit evidence of final, continuing insurance for one year's coverage complying with insurance requirements.
- C. Re-inspection Procedure: The Engineer will re-inspect the work upon receipt of notice that the Work, including inspection list items from earlier inspections, has been completed, except items whose completion has delayed because of circumstances acceptable to the Engineer.
1. Upon completion of re-inspection, the Engineer will prepare a Certificate of Final Acceptance, or advise the Contractor of work that is incomplete, or of obligations that have not been fulfilled, but are required for Final Acceptance.

### CONTRACT CLOSEOUT 01710-2

2. If necessary, re-inspection will be repeated.

## 1.5 RECORD DOCUMENT SUBMITTALS

- A. Record Drawings: Submit As-Built Drawings of the piping, storm drainage structures and all appurtenances. Drawings will be submitted to the Engineer at the completion of the job as specified in Section 01300. Drawings shall be neat, accurate and thorough and submitted in hard copy format (8 1/2 x 11 sheets) and electronically as AutoCAD files.

## PART 2- PRODUCTS (NOT USED)

## PART 3 -EXECUTION

### 3.1 FINALCLEANING

- A. During its progress, the work and the adjacent areas affected thereby shall be cleaned up and all rubbish, surplus materials, and unneeded construction equipment shall be removed and all damage repaired so that the public and property owners will be inconvenienced as little as possible.
- B. Where material or debris has washed or flowed into or been placed in existing watercourses, ditches, gutters, drains, pipes structures, work done under this contract, or elsewhere during the course of the Contractor's operations, such material or debris shall be entirely removed and satisfactorily disposed of during the progress of the work, and the ditches, channels, drains, pipes, structures, and work, etc., shall, upon completion of the work, be left in a clean and neat condition.
- C. On or before the completion of the work, the Contractor shall, unless otherwise especially directed or permitted in writing, tear down and remove all temporary buildings and structures built by him; shall remove all temporary works, tools, and machinery or other construction equipment furnished by him; shall remove, acceptably disinfect, and cover all organic matter and material containing organic matter in, under, and around privies, houses, and other buildings used by him; shall remove all rubbish from any grounds which he has occupied; and shall leave the roads and all parts of the premises and adjacent property affected by his operations in a neat and satisfactory condition.
- D. Removal of Protection: Remove temporary protection and facilities installed for protection of the work during construction.
- E. Compliance: Comply with regulations of authorities having jurisdiction and safety standards for cleaning. Do not burn waste materials. Do not bury debris or excess materials on the Town's property. Do not discharge volatile, harmful, or dangerous materials into drainage systems. Remove waste materials from the site and dispose of in a lawful manner.
- F. The Contractor shall restore or replace, when and as directed, any public or private property damaged by his work, equipment, or employees, to a condition at least equal to that existing immediately prior to the beginning of operations. To this end the Contractor shall do as required all necessary highway or driveway, walk, and landscaping work.

## CONTRACT CLOSEOUT

01710-3

Suitable materials, equipment, and methods shall be used for such restoration. The restoration of existing property or structures shall be done as promptly as practicable as work progresses and shall not be left until the end of the contract period.

END OF SECTION 01710

CONTRACT CLOSEOUT  
01710-4

Sump Pump Amnesty Program  
Contract 2- Areas 5B, 5D and 15  
Waltham, Massachusetts

## **Division 2 – Site Work**

SECTION 02020

EROSION AND SEDIMENT CONTROL

PART 1 GENERAL

1.1 SUMMARY

- A. This Section specifies equipment and materials for an erosion and sediment control program installation during the construction phase of the project. The erosion and sediment control provisions detailed on the Drawings and specified herein are the minimum requirements for an erosion control program. The Contractor shall provide additional erosion and sediment control materials and methods as required to affect the erosion and siltation control principles specified herein.

1.2 RELATED SECTIONS

- A. Examine Contract Documents and Drawing Details for requirements that affect work of this Section. Other Specification Sections that directly relate to work of this Section include, but are not limited to:
  - 1. Section 01110 Environmental Protection Procedures

1.3 SUBMITTALS

- A. Proposed methods, materials to be employed, and schedule for effecting erosion and siltation control and preventing erosion damage shall be submitted for approval. Submittals shall include:
  - 1. List of proposed materials including manufacturer's product data.
  - 2. Erosion Controls shall be installed prior to construction. Schedule of erosion control program indicating specific dates from implementing programs in each major area of work, including Erosion Control installation and truck wheel wash station installation.

B. Samples

The following samples shall be submitted:

<u>Sample</u>	<u>Size</u>
Filter Fabric (Woven and Non-Woven)	12 X 12 in.

1.4 REFERENCES

- A. The publications listed below form a part of this specification to the extent referenced. The publications are referred to in the text by basic designation only.

EROSION AND SEDIMENT CONTROL

02020-1

1. Massachusetts Department of Public Works, and The Commonwealth of Massachusetts Department of Public Works; Construction Standards.
2. Massachusetts Department of Environmental Protection.

## 1.5 EROSION CONTROL PRINCIPLES

### A. Erosion Control Principles

The following erosion control principles shall apply to the land grading and construction phases:

1. Stripping of vegetation, grading, or other soil disturbance shall be done in a manner which will minimize soil erosion.
2. Whenever feasible, natural vegetation shall be retained and protected.
3. Extent of area which is exposed and free of vegetation and duration of its exposure shall be kept within practical limits.
4. Temporary seeding, mulching, or other suitable stabilization measures shall be used to protect exposed critical areas during prolonged construction or other land disturbance. Prolonged exposure of unstabilized soil shall not exceed 60 days.
5. Drainage provisions shall accommodate increased runoff resulting from modifications of soil and surface conditions during and after development or disturbance. Such provisions shall be in addition to existing requirements.
6. Sediment shall be retained on-site.
7. Erosion control devices and truck wheel wash station shall be installed prior to start of clearing and grubbing operations and excavation work.

### B. Erosion Protection

Cut and fill slopes and stockpiled materials shall be protected to prevent erosion. Slopes shall be protected with permanent erosion protection when erosion exposure period is expected to be greater than or equal to two months, and temporary erosion protection when erosion exposure is expected to be less than two months.

1. Permanent erosion protection shall be accomplished by seeding with grass and covering with an erosion protection material, as appropriate for prevailing conditions.
2. Temporary erosion protection shall be accomplished by covering with an erosion protection materials, as appropriate for prevailing conditions.

## EROSION AND SEDIMENT CONTROL 02020-2



3. Except where specified slope is indicated on Drawings, fill slopes shall be limited to a grade of 4:1 (horizontal: vertical) cut slopes shall be limited to a grade of 4:1.

## PART 2 -PRODUCTS

### 2.1 STRAW BALES

- A. Straw bales for construction of erosion control devices shall be new, firm, bound salt marsh straw bound with biodegradable twine.

### 2.2 TEMPORARY SEED COVER

- A. If required, seed mixture for temporary cover by hydroseeding application shall conform to the following:

<u>Quantity per 1000 sq. ft. Coverage</u>	<u>Material</u>
27-1/2 lb.	Wood Fiber Mulch
4lb.	Seed
1/2 lb.	Annual Ryegrass
22lb.	10-6-4 Fertilizer
69 gal	Water

- B. Hydroseeding Equipment

Hydroseeding equipment may be either portable or truck mounted, with dual agitation, a minimum working volume of 1000 gallons and a minimum spray range of 80 ft.

1. Hydroseeding equipment must be capable of uniformly applying the slurry mix including wood fiber mulch if required, at the specified rate, and at the required locations.
2. Hydromulching equipment, either trailer or truck mounted, must be capable of uniformly applying straw or straw mulch at a minimum mulching rate of 8 tons per hour, at a distance of not less than 80 ft.

### 2.3 FILTER BASKETS

- A. Filter baskets shall be Metal-Era Inlet Baskets, manufactured by Metal-Era Inc., Wukesha, WI 53186, approved equal. Baskets shall be installed at all newly installed and existing catch basins and remain in place until vegetation on the site is stabilized. Filter basket shall include a nonwoven geotextile filter fabric material with a minimum Grab strength of 45 lb., Mullen Burst Strength of 60 psi minimum, a minimum permeability of 120 gpm/sq. ft., and an opening no greater than No. 20 U.S. Standard Sieve.

## EROSION AND SEDIMENT CONTROL 02020-3

## PART 3 EXECUTION

### 3.1 HYDROSEEDING

- A. If required for long-term disturbance greater than 60 days, seed for temporary cover shall be spread by the hydroseeding method, utilizing power equipment commonly used for that purpose. Seed, fertilizer, mulch and water shall be mixed and applied to achieve application quantities specified. Material shall be applied in 2 equal applications, with the equipment during the second pass moving perpendicular to direction employed during the first pass. Hydroseeding shall not be done when it is raining or snowing, or when wind velocity exceeds 5 mph.
- B. If the results of hydroseeding application are unsatisfactory, the mixture and/or application rate and methods shall be modified to achieve the required results.
- C. After the grass has appeared, all areas and parts of areas which fail to show a uniform stand of grass, for any reason whatsoever, shall be reseeded and such areas and parts of areas seeded repeatedly until all areas are covered with a satisfactory growth of grass.

### 3.2 FILTER BASKETS

- A. Filter baskets shall be installed at all newly installed and existing catch basins. Filter baskets shall be installed in accordance with manufacturer's recommendations. Maintain filter baskets as required and as follows. Baskets shall be inspected within 24 hours after each rainfall or daily during extended periods of precipitation. Repairs shall be made immediately, as necessary, to prevent particles from reaching the drainage system. Sediment deposits shall be removed after each storm event, or more often if the fabric becomes clogged. Clean clogged fabric and repair or replace damaged filter fabric as necessary.

### 3.3 MAINTENANCE AND REMOVAL OF EROSION CONTROL DEVICES

- A. Wetland area, water courses, and drainage swales adjacent to construction activities shall be monitored continuously for evidence of silt intrusion and other adverse environmental impacts, which shall be corrected immediately upon discovery.
- B. Culverts and drainage ditches shall be kept clean and clear of obstructions during construction period.
- C. Erosion Control Devices
  - 1. Sediment behind the erosion control device shall be checked twice each month and after heavy rain. Silt shall be removed if greater than 6 in. deep.
  - 2. Condition of erosion control device shall be checked twice each month or more frequently as required. Damaged and/or deteriorated items shall be replaced. Erosion control devices shall be maintained in place and in effective condition.

## EROSION AND SEDIMENT CONTROL 02020-4

3. Straw bales shall be inspected frequently and maintained or replaced as required to maintain both their effectiveness and essentially their original condition. Underside of bales shall be kept in close contact with the earth below at all times, as required to prevent water from washing beneath bales.
4. Sediment deposits shall be properly disposed of, in a location and manner which will not cause sediment nuisance elsewhere.

D. Removal of Erosion Control Devices

1. Erosion control devices shall be maintained until all disturbed earth has been paved or vegetated, at which time they shall be removed. After removal, areas disturbed by these devices shall be regraded and seeded.
2. Erosion protection material shall be kept securely anchored until acceptance of the entire Project.

END OF SECTION 02020

EROSION AND SEDIMENT CONTROL  
02020-5

SECTION 02100  
SITE PREPARATION

PART I- GENERAL

1.1 RELATED DOCUMENTS

- A. Drawings and general provisions of the Contract, including General and Supplementary Conditions and Division 1 Specification Sections, apply to this section.

1.2 SUMMARY

- A. This section includes the following:
  - 1. Provide labor, material, tools and equipment to prepare site as indicated and specified.
- B. Related sections include the following:
  - 1. Section 02200: Earthwork

PART 2- PRODUCTS

2.1 WOOD CHIPS

- A. Chip from cleared wood.
- B. Provide additional wood chips as directed by Engineer.
- C. Do not permit use of elm wood and elm bark as wood chips.

PART 3- EXECUTION

3.1 EXISTING TREES AND VEGETATION

- A. Avoid cutting or injuring trees and vegetation outside easement line and Outside areas to be cleared as indicated, without Engineer's permission Protect existing trees from damage.
- B. Accept responsibility for damages outside these lines.

SITE PREPARATION  
02100-1

- C. Remove trees within permanent and temporary easement as designated by Engineer.

### 3.2 EXISTING STRUCTURES AND PROPERTY

- A. Remove existing signs, posts, catchbasin frames and grates, manhole frames and covers, and granite curbing within construction path unless directed otherwise.
- B. Store at a site designated by Owner, items in reusable condition as determined by Engineer.
- C. For work in loamed areas, strip loam to one side to avoid mixing with excavation materials. Do not take loam from site.

### 3.3 CLEARING

- A. Cut or remove trees, brush, and other vegetable matter such as snags, bark and refuse, from areas to be cleared. Clear ground to width of permanent easement unless otherwise directed.
- B. Cut trees, stumps, and stubs to be cleared, except where clearing done by machinery, as close to ground surface as practicable, but no more than 6 in. above ground surface for small trees and 12 in. for larger trees.
- C. Bury elm bark, at least 1 ft. deep, or burn in incinerators off site with anti- pollution controls and fire prevention controls, to prevent spread of Dutch Elm disease as required by applicable laws.

### 3.4 CLEARING IN WOODED AREAS

- A. Chip and stockpile wood cleared at location directed by Owner. Do NOT PERMIT use of elm wood and elm bark as wood chips.
- B. Chip and spread wood cleared at locations and cover as indicated. Do NOT PERMIT use of elm wood and elm bark as wood chips.
- C. Supply and spread wood chips.

### 3.5 GRUBBING, STRIPPING, DISPOSAL

- A. Remove stumps and roots larger than 3 in. in diameter to a depth of 12 in., and roots larger than 1/2 in. in diameter to a depth of 6 in. Measure depths to cut from existing ground surface or proposed finished grade, whichever is lower.

## SITE PREPARATION 02100-2

- B. Strip stumps, roots, foreign matter, topsoil, loam and unsuitable earth from ground surface. Utilize topsoil and loam insofar as possible for finished surfacing. Do not take loam from site.
- C. Promptly dispose off site material from clearing and grubbing not reused or stockpiled. In doing so, observe all applicable laws, ordinances, rules and regulations. Do not consider work completed until final cleaning, unless otherwise directed.

3.6 CONTRACT CLOSEOUT

- A. Provide in accordance with Section 01710.

END OF SECTION 02100

SITE PREPARATION  
02100-3

SECTION 02101

SITE INVESTIGATION

PART 1 GENERAL

1.1 SITE CONDITIONS

- A. The Contractor acknowledges that he has satisfied himself as to the nature and location of the work, the general and local conditions, particularly those bearing upon transportation, disposal, handling, and storage of materials, availability of labor, water, electric power, roads and uncertainties of weather, groundwater table or similar physical conditions at the site, the conformation of subsurface materials to be encountered, the character of equipment and facilities needed prior to and during the prosecution of the work and all other matters which can in any way affect the work or the cost thereof under this Contract. Any failure by the Contractor to acquaint himself with all available information concerning these conditions will not relieve him from responsibility for estimating properly the difficulty or cost of successfully performing the work.

1.2 SUBSURFACE DATA

- A. The Contractor acknowledges that he assumes all risk contingent upon the nature of the subsurface conditions, to be actually encountered by him in performing the work covered by the Contract, even though such actual conditions may result in the Contractor performing more or less work than he originally anticipated.

PART 2 PRODUCTS (NOT USED)

PART 3- EXECUTION (NOT USED)

END OF SECTION 02101

SITE INVESTIGATION  
02101-1

## SECTION 02140

### DEWATERING AND DRAINAGE

#### PART I-GENERAL

##### 1.1 SCOPE OF WORK

- A. Furnish, install, operate, monitor, maintain, and remove temporary dewatering and drainage systems as necessary to lower and maintain groundwater levels below subgrades of excavations and prevent surface water runoff from entering or accumulating in excavations, to permit construction in the dry.
- B. Collect and properly dispose of all discharge water from dewatering and drainage systems in accordance with local requirements and permits.
- C. Repair any damage caused by dewatering and drainage system operations.
- D. Remove temporary dewatering and drainage systems when no longer needed, and restore all disturbed areas.

##### 1.2 RELATEDWORK

- A. Trenching, backfilling, and compacting included in Section 02221. B. Environmental Protection Measures is included in Section 01110.

##### 1.3 SUBMITTALS

- A. Submit the proposed temporary dewatering and drainage system designs. Contractor shall remain responsible for adequacy and safety of construction means, methods, and techniques.

##### 1.4 DEFINITIONS

- A. Where the phrase "in-the-dry" is used in these specifications, it shall be defined as soil conditions that are no more than two percentage points above the optimum moisture content for that soil.

##### 1.5 QUALITY ASSURANCE

- A. Provide in accordance with Section 01400 and as specified.
- B. Employ the services of a dewatering specialist or firm having the following qualifications:

### DEWATERING AND DRAINAGE

02140-1



1. Have completed at least five (5) successful dewatering projects of equal size and complexity and with equal systems within the last five (5) years.
  2. Retain the services of a Registered Professional Engineer (in the state where the project is located) having a minimum of five (5) years experience in the design of well points, deep wells, recharge systems, or equal systems.
  3. Retain the services of a field representative having a minimum of 5 years experience in installation of well points, deep wells, recharge systems, or equal systems.
- B. If subgrade soils are disturbed or become unstable due to dewatering operation or an inadequate dewatering system, notify the Engineer, stabilize the subgrade, and modify system to perform as specified at no additional cost to the Owner.
- C. Notify the Engineer immediately if any settlement or movement is detected on structures. If the settlement or movement is deemed by the Engineer to be related to the dewatering, take actions to protect the adjacent structures and submit a modified dewatering plan to the Engineer within 24 hours. Implement the modified plan and repair any damage incurred to the adjacent structures at no additional cost to the Owner.
- D. If oil and/or other hazardous materials are encountered after dewatering begins, immediately notify the Engineer.

## PART 2- PRODUCTS

### 2.1 MATERIALS

- A. Piping, pumping equipment and all other materials required to dewater excavations shall be suitable for the intended purpose. Standby pumping units shall be maintained at the site to be used in case of failure of the normal pumping units. Do not excavate until the dewatering system is operational
- B. Provide and store auxiliary dewatering equipment, consisting of pumps and hoses on the site in the event of breakdown, a minimum of one (1) working auxiliary pump is required, and an additional one (1) pump for every five (5) used.
- C. Provide and maintain erosion/sedimentation control devices as indicated or specified and in accordance with the dewatering plan.
- D. Provide temporary pipes, hoses, flumes, or channels for the transport of discharge water to the discharge location.
- E. Provide cement grout having a water cement ratio of 1 to 1 by volume.

## DEWATERING AND DRAINAGE

02140-2

## PART 3- EXECUTION

### 3.1 GENERAL

- A. Surface water and groundwater shall be controlled such that excavation to final grade is made in-the-dry, the bearing soils are maintained undisturbed, and softening or instability of, or disturbance to, the subgrade due to the presence or seepage of water does not occur.
- B. All work shall be protected from flotation.
- C. The impact of anticipated subsurface soil/water conditions shall be factored into the selection of methods of excavation and proposed dewatering and drainage systems. Where groundwater levels are above the proposed bottoms of excavations, it is expected that some type of pumped dewatering system will be required for predrainage of the soils prior to excavation to final grade and for maintaining the lowered groundwater level until construction has been completed to such an extent that the foundation, structure, pipe, conduit, or fill will not be floated or otherwise damaged. It is further expected that the type of system, spacing of dewatering units, and other details of the work will vary depending on soil/water conditions at a particular location.

### 3.2 SURFACE WATER CONTROL

- A. Surface water control measures shall be constructed to prevent flow of surface waters into excavations. Such measures may include dikes, ditches, and sumps.

### 3.3 EXCAVATION DEWATERING

- A. Provide and maintain adequate equipment and facilities to remove promptly and dispose of properly all water entering excavations. Excavations shall be kept in-the-dry, so as to maintain an undisturbed subgrade condition throughout construction below grade, including backfill and fill placement.
- B. Water entering excavations from precipitation or surface runoff shall be collected in shallow ditches around the perimeter of the excavation; drained to sump, and pumped from the excavation to maintain in-the-dry conditions.
- C. Pipe and conduit shall not be laid in water or allowed to be submerged prior to backfilling. Pipe and conduit which becomes submerged shall be removed and excavation dewatered and restored to proper conditions prior to reinstalling the pipe and conduit.
- D. Excavations for foundations and structures shall be maintained in-the-dry for a minimum of four days after concrete placement. In no event shall water be allowed to enter an excavation and rise to cause unbalanced pressure on foundations structures until the concrete or mortar has set at least 24 hours.

## DEWATERING AND DRAINAGE

02140-3

- E. Dewatering and drainage operations shall at all times be conducted in such a manner as to preserve the natural undisturbed bearing capacity of the subgrade at the bottom of the excavation. If the subgrade becomes disturbed for any reason, the unsuitable subgrade material shall be removed and replaced with concrete, compacted granular fill, or other approved material to restore the bearing capacity of the subgrade to its natural undisturbed condition.
- F. Dewatering and drainage operations shall be conducted in a manner which does not cause loss of ground or disturbance to the pipe bedding or soil which supports overlying or adjacent structures.

### 3.4 DISPOSAL OF DRAINAGE

- A. All water discharged from temporary dewatering and drainage systems shall be disposed of in accordance with approved sedimentation and control plans and methods. Existing or new sanitary sewer systems or private on-site septic systems shall not be used to dispose of drainage.

END OF SECTION 02140

## DEWATERING AND DRAINAGE 02140-4

## SECTION 02200

### EARTHWORK

#### PART 1- GENERAL

##### 1.1 SUMMARY

- A. This Section includes excavations of normal depth in earth for trenches and structures; backfilling such excavations to the extent required; filling; rough grading;; constructing embankments; miscellaneous earth excavation; the removal, hauling and stockpiling of suitable excavated material for subsequent re-use in the work; all rehandling, hauling and placing of stockpiled materials for use in refilling, filling, backfilling, grading and such other operations; the removal and satisfactory disposal off site of unsuitable material; and appurtenant work, complete, in accordance with the Drawings and Specifications, and as directed.

##### RELATED SECTIONS

- A. Drawings and general provisions of the Contract including General and Supplemental Conditions and Division 1 Specification Sections, apply to this section and:
  - 1. Section 02020 Erosion and Sediment Control
  - 2. Section 02273 Geotextile Fabrics
  - 3. Section 02920 Topsoil

##### 1.3 SUBMITTALS

- A. General: Submit the following in accordance with Conditions of Contract and Division 1 Specification Sections.
- B. Backfill Materials Source Verification: Submit 50 pound sample for each proposed source of backfill materials. Submit a grain size analysis and curve performed in accordance with ASTM D422 for each proposed source of backfill for review by the Engineer. The grain size analysis shall indicate that the backfill material conforms to the specified gradation requirements. Material obtained from the cuts on the site can be used for backfill provided that it meets the spec for Common Fill or Gravel Borrow contained herein.
- C. Submit a moisture-density curve indicating the maximum dry density and optimum moisture content as determined by ASTM D1557 for each proposed source of compacted backfill for review of the Engineer.
- A. Filter fabric: Submit the manufacturer's information and a one square foot representative sample of the filter fabric (Section 02273) to the Engineer for review.

### EARTHWORK 02200-1

- E. Within one week of a field change, resubmit revised working drawings as necessary to reflect changes required by field conditions.
- F. Submit reports from the geotechnical testing laboratory documenting all earthwork activity and field testing. The field reports shall include as a minimum the following:
  - 1. A description of the day's activities.
  - 2. The results of in-place density testing including in-place dry density, moisture content, percent compaction, elevation of test and a description of the soil.
  - 3. A sketch indicating the extent of each day's work and the location of testing.
- G. Submit the qualifications of the certified independent geotechnical testing laboratory performing soil testing and inspection services during earthwork operations. The geotechnical testing laboratory must demonstrate to the Engineer's satisfaction, based on evaluation of laboratory submitted criteria conforming to ASTM D3740, that it has the experience and capability to conduct required field and laboratory geotechnical testing. In addition, the laboratory shall be supervised by a Registered Professional Engineer.

#### 1.4 EXCAVATION CLASSIFICATIONS

- A. Earth Excavation or "Excavation" consists of removal of materials encountered to the subgrade elevations indicated and subsequent reuse or disposal of the materials removed. All excavation is classified as earth excavation unless it otherwise meets the classifications provided below for unauthorized excavation, additional excavation, or rock excavation.
- B. Unauthorized Excavation consists of removal of materials beyond indicated subgrade elevations or dimensions without specific direction of the Engineer. Unauthorized excavation, as well as remedial work directed by the Engineer, shall be at Contractor's expense.
  - 1. Under footings, foundations bases, concrete slabs, retaining walls or other structures, fill unauthorized excavations to the proper elevations with lean concrete. Elsewhere, backfill and compact unauthorized excavations as specified for excavations of the same class, otherwise directed by the Engineer.
- C. Additional Excavation.
  - 1. When excavation has reached required subgrade elevations, notify the Engineer who will review subgrade conditions..

### EARTHWORK 02200-2

2. If unsuitable bearing materials are encountered at required subgrade elevations, carry excavations deeper and replace excavated material as directed by the Engineer.

## 1.5 ROCKEXCAVATION

- A. Rock excavation in trenches and pits includes removal and disposal of materials and obstructions encountered which cannot be excavated with a 1.0 cubic yard (heaped) capacity, 42-inch wide bucket on track-mounted power excavator equivalent to Caterpillar Model 215, rated at not less than 90 HP flywheel power and 30,000 lb. drawbar pull. Trenches in excess of 10 feet 0-inches in width and pits in excess of 30 feet 0-inches in either length or width are classified as open excavation.
- B. Rock excavation in open excavations includes removal and disposal of materials and obstructions encountered which cannot be dislodged and excavated with modern track-mounted heavy-duty excavation equipment without drilling, blasting or ripping. Rock excavation equipment is defined as Caterpillar Model No. 973 or No. 977K, or equivalent track-mounted loader, rated at not less than 170HP flywheel power and developing 40,000 lb. break-out force (measured in accordance with SAE J732C).
- C. Determination of rock excavation classification will be made by the Engineer. Typical of materials classified of rock are boulders 1.0 cu. yd. or more in volume, solid rock, rock in ledges, and rock-hard cementitious aggregate deposits. Intermittent drilling, blasting or ripping performed to increase production and not necessary to permit excavation of material encountered will be classified as earth excavation. Do not perform rock excavation work until material to be excavated has been cross-sectioned and classified by Engineer. If the area to be excavated is pre-blasted prior to the excavation of overburden soils, the Engineer shall be notified at least two days in advance to allow observation of the pre-blast drilling by the Engineer in order to classify the excavation. Visual observation of the completed excavation may be made by the Engineer to modify the excavation classifications. Removal of rock excavation prior to classification by the Engineer shall be considered as earth excavation unless accepted by the Engineer in writing. Such excavation will be paid on the basis of contract unit rates for this classification. If site rock or trench rock is encountered, the contractor must submit a plan for its removal to the Engineer for approval. Excess boulder and rocks must be removed from the site.
- D. Rock payment lines are limited to the following:
  1. Two feet outside of concrete work for which forms are required, except footings.
  2. One foot outside the perimeter of footings.

## EARTHWORK 02200-3

3. Rock in pipe trenches shall be measured from its surface to 6-inches below the outside of the pipe and with a width of two (2) feet greater than the inside diameter of the pipe but not less than 3 feet minimum trench width. Any rock excavated to a depth or width greater than the above shall be removed and backfilled with ordinary borrow at the Contractor's expense.

## 1.6 EXCAVATION

- A. The Contractor shall perform all excavations of every description and of whatever substances encountered, in a manner as required to allow for placing of temporary earth support, forms, installation of pipe and other work, and to permit access to the Engineer for the purpose of observing the work. Excavations shall be to such widths as will give suitable space for the required work. Bottoms of trenches and excavations shall be protected from frost and shall be firm, dry and in an acceptable condition to receive the work; work shall not be placed on frozen surfaces nor shall work be placed on wet or unstable surfaces.
- B. All excavations made in open cut will be controlled by the conditions existing at the various locations and shall always be confined to the limits as designated by the Engineer. In no case shall earth be excavated or disturbed by machinery so near to the finished subgrade for structures and pipelines as to result in the disturbance of the earth below the subgrade. The final excavation to subgrade should be accomplished with a smooth faced bucket or by hand if directed by the Engineer.

## 1.7 GROUNDWATERCONTROL

- A. The Contractor shall provide, at his own expense, adequate pumping and drainage facilities to maintain the excavated area(s) sufficiently dry from groundwater and/or surface runoff so as not to adversely affect construction procedures nor cause excessive disturbance of underlying natural ground. The drainage of all water resulting from pumping shall be managed so as not to cause damage to adjacent down-gradient property or resource areas.
- B. Any damage resulting from the failure of the dewatering operations of the Contractor, and any damage resulting from the failure of the Contractor to maintain all the areas of work in a suitable dry condition, shall be repaired by the Contractor, as directed by the Engineer, at no additional expense to the Owner. The Contractor's pumping and dewatering operations shall be carried out in such a manner as to prevent damage to the Contract work and so that no loss of ground will result from these operations. Precautions shall be taken to protect new work from flooding during storms or from other causes. Pumping shall be continuous where directed by the Engineer to protect the work and/or to maintain satisfactory progress.
- C. All pipelines or structures not stable against uplift during construction or prior to completion shall be thoroughly braced or otherwise protected. Water from the trenches, excavations and drainage operations shall be disposed of in such a manner as to avoid public nuisance, injury to public health or the environment, damage to public or private property, or resource areas, or damage to the work completed or in progress.

## EARTHWORK 02200-4

- D. The Contractor shall control the grading in the areas surrounding all excavations so that the surface of the ground will be properly sloped to prevent water from running into the excavated area. Where required, temporary ditches shall be provided for drainage. Upon completion of the work and when directed, all areas shall be restored by the Contractor in a satisfactory manner and as directed.

**PART 2- PRODUCTS**

**2.1 BACKFILL MATERIALS**

- A. Ordinary Borrow: Ordinary Borrow (MHD M1.01.0) shall be soil containing no stone greater than 2/3 loose lift thickness. The materials shall be free of trash, ice, snow, tree stumps, roots and other organic and deleterious materials. Ordinary Borrow shall not contain more than 30 percent by weight of soil material passing the number 200 sieve. It shall be of such a nature and character that it can be compacted to the specified densities in a reasonable length of time. Topsoil and subsoil shall not be considered Ordinary Borrow. Ordinary Borrow shall be used for general subgrade fill areas.
- B. Structural Fill: Structural Fill shall be used beneath foundations and slabs and as backfill of foundations and other load bearing structures. Structural Fill shall consist of inert material that is hard, durable stone and coarse sand, free from loam and clay, surface coatings and deleterious materials. The gradation shall meet the following requirements:

SIEVE DESIGNATION	NOMINAL PERCENT PASSING BY WEIGHT
6 inch	100
3 inch	70-100
¾ inch	40-95
No. 4	30-90
No. 10	25-80
No. 40	10-50
No. 200	0-12

- C. Processed Gravel for Subbase: Processed gravel for subbase shall be used where specified as sidewalk and pavement subbase material and shall consist of inert material that is hard, durable stone and coarse sand free from frost, frozen lumps, loam and clay, surface coatings, and deleterious materials.

Gradation requirements for Processed gravel for subbase shall be as designated by MHD M1.03.1 and shall conform to the following:

SIEVE DESIGNATION	NOMINAL PERCENT PASSING BY WEIGHT
3 inch	100
1 ½"	70-100
1/4"	50-85
No. 4	30-60
No. 200	0-10

**EARTHWORK  
02200-5**



- D.  $\frac{3}{4}$ " Crushed Stone:  $\frac{3}{4}$ " Crushed stone should be used where specified as bedding under pipes and structures, as a working mat, as a filter around perforated drain pipe or as backfill behind retaining walls. Crushed stone shall consist of durable crushed rock or durable crushed gravel stone, free from ice and snow, sand, clay, loam, or other deleterious or organic material. The crushed stone gradation requirement shall be as designated by MHD M2.01.4 and shall be uniformly blended and shall conform to the following requirements.

SIEVE DESIGNATION	NOMINAL PERCENT PASSING BY WEIGHT
1 inch	100
$\frac{3}{4}$ -inch	70-100
$\frac{1}{2}$ -inch	10-50
$\frac{3}{8}$ -inch	0-20
No. 4	0-5

- E. 1  $\frac{1}{2}$ " Crushed Stone: 1  $\frac{1}{2}$ " Crushed stone should be used where specified as bedding under pipes and structures, as a working mat, as a filter around perforated drain pipe or as backfill behind retaining walls. Crushed stone shall consist of durable crushed rock or durable crushed gravel stone, free from ice and snow, sand, clay, loam, or other deleterious or organic material. The crushed stone gradation requirement shall be as designated by MHD M2.01.1 and shall be uniformly blended and shall conform to the following requirements.

SIEVE DESIGNATION	NOMINAL PERCENT PASSING BY WEIGHT
2 inch	100
1 $\frac{1}{2}$ inch	95-100
1 inch	35-70
$\frac{3}{4}$ -inch	0-25

- F. Dense Graded Crushed Stone for Subbase: Dense graded crushed stone for subbase should be used where specified as pavement and sidewalk sub-base material, only if a deficit of reclaimed material occurs. Dense graded crushed stone shall consist of durable crushed rock or durable crushed gravel stone combined with fine aggregates of natural sand or stone screenings uniformly premixed with a predetermined quantity of water. The composite material shall be free from ice and snow, clay, loam, or other deleterious or organic material. The dense graded crushed stone for subbase gradation requirement shall be as designated by MHD M2.0 I.7 and shall be uniformly blended and shall conform to the following requirements.

SIEVE DESIGNATION	NOMINAL PERCENT PASSING BY WEIGHT
2 inch	100
1 $\frac{1}{2}$ inch	70-00
$\frac{3}{4}$ -inch	50-85
No. 4	30-55
No. 50	8-24
No. 200	3-10

**EARTHWORK**  
02200-6

- G. Gravel borrow: Gravel borrow shall consist of inert material that is hard, durable stone and coarse sand free from frost, frozen lumps, loam and clay, surface coatings, and deleterious materials.

Graduation requirements for gravel shall be determined by AASHTO-T11 and T27 and shall conform to the following:

SIEVE DESIGNATION	NOMINAL PERCENT PASSING BY WEIGHT
1/2 inch	50-85
No. 4	40-75
No. 50	8-28
No. 200	0-10

Maximum size of stone in gravel shall be as follows:

- 6 inches largest dimension      Type a
- 3 inches largest dimension      Type b
- 2 inches largest dimension      Type c

- H. Bank-run gravel: Bank run gravel shall be obtained from approved natural deposits and unprocessed except for the removal of deleterious materials and stones larger than the maximum size permitted.

Bank-run gravel shall be unfrozen and substantially free from vegetation, roots, loam and other organic matter, clay, snow, frozen particles and other fine or harmful substances.

Bank-run gravel: Inorganic granular material meeting the following gradation:

SIEVE DESIGNATION	NOMINAL PERCENT PASSING BY WEIGHT
6 inch	100
2 inch	80-100
No. 4	20-65
No. 200	00-12

## PART 3 EXECUTION

### 3.1 FILLING AND BACKFILLING

- A. Verify locations and elevations of existing utilities. Maintain and protect utilities which are to remain.
- B. Verify that survey bench marks, horizontal control points, and intended elevations for the work are as shown on the Drawings. Protect survey control points and existing structures.

## EARTHWORK 02200-7

- C. Sequence the work such that work associated with lower elevations and utilities are completed before placing higher elevations and utilities.
- D. Stockpiles shall be neatly trimmed and graded to provide drainage from surfaces and to prevent depressions where water may become impounded. Stockpiles shall be protected and shall not be disturbed. Unsuitable soils shall be segregated and legally disposed by the contractor at no additional cost to the Owner.
- E. Subgrade Preparation: After the subgrade has been shaped to line, grade, and cross-section, it shall be thoroughly compacted. This operation shall include any required reshaping and wetting to obtain proper compaction. All soft or otherwise unsuitable material shall be removed and replaced with suitable material from excavation or borrow. The resulting area, and all other low sections, holes, or depressions shall be brought to the required grade with accepted material and the entire subgrade shaped to line, grade and cross-section and thoroughly compacted.
- F. Backfill Material Selection: Unless otherwise specified or directed, material used for filling and backfilling shall meet the requirements specified under Backfill Materials (Part 2). In general, the material used for backfilling utility trench excavations shall be material removed from the excavations provided that the reuse of these materials result in the required trench compaction and meets the requirements specified for common fill. All backfill placed beneath concrete slabs shall be structural fill unless otherwise specified. In areas where the bottom of the excavation is in fine sand and silt, and is below the groundwater table, the first lift of backfill shall be 12-inches of compacted sand and gravel (Gravel Borrow) to provide a working mat and drainage layer.

Place backfill to a maximum loose lift thickness of 12 inches. Maintain backfill material with a uniform moisture content, with no visible wet or dry streaking, between plus 2 percent and minus 3 percent of optimum moisture content. The final filled soil mass shall be as uniform as possible in lift thickness, moisture content, and effort required to compact soil mass.

- G. Trench Backfill:
  - 1. The trenches shall be backfilled as soon as practicable with suitable material. All trench backfilling shall be done with special care, in the following manner and as directed by the Engineer.
  - 2. Backfill material for pipe bedding shall be deposited in the trench, uniformly on both sides of the pipe, for the entire width of the trench to the springline of the pipe. The selected backfill material shall be placed by hand shovels, in layers not more than 12-inches thick in loose depth, and each layer shall be thoroughly and evenly compacted by tamping on each side of the pipe to provide uniform support around the pipe, free from voids.

## EARTHWORK 02200-8

3. The balance of backfill shall be spread in layers not exceeding 12-inches in loose depth. Each layer shall be thoroughly compacted by mechanical methods and shall contain no rock, stones or boulders larger than 4-inches in their greatest dimension.
4. All trench backfilling shall be done with special care and must be carefully placed so as not to disturb the work at any time; if necessary, a timber grillage or other suitable method shall be used to break the fall of material. The moisture content of the backfill material shall be such that proper compaction will be obtained. Puddling of backfill with water will not be permitted. Backfill within areas to receive topsoil or pavement construction shall be made to grades required to establish the proper subgrade for the placement of topsoil or pavement base courses.
5. In backfilling trenches, each layer of backfill material shall be moistened and compacted to a density at least equal to that of the surrounding undisturbed earth, and in such a manner as to permit the rolling and compaction of the filled trench or excavation with the adjoining earth to provide the required bearing value, so that paving or foundation construction of the excavated and disturbed areas, where required, can proceed immediately after backfilling is completed.
6. Any trenches or excavations improperly backfilled or where settlement occurs shall be reopened, to the depth required for proper compaction, then refilled and compacted with the surface restored to the required grade and condition, at no additional expense to the Owner.
7. During filling and backfilling operations, pipelines will be checked by the Engineer to determine whether any displacement of the pipe has occurred. If the observation of the pipelines shows poor alignment, displaced pipe or any other defects they shall be remedied in a manner satisfactory to the Engineer at no additional cost to the Owner.

H. Backfilling Against Structures:

1. Backfilling against masonry or concrete shall not be done until permitted by the Engineer. The Contractor shall not place backfill against or on structures until they have attained sufficient strength to support the loads (including construction loads) to which they will be subjected, without distortion, cracking or other damage. As soon as practicable after the structures are structurally adequate and other necessary work has been satisfactorily completed, special leakage tests of the structures shall be made by the Contractor, as required by the Engineer. After the satisfactory completion of leakage tests and the satisfactory completion of any other required work in connection with the structures, the backfilling around the structures shall proceed using suitable and approved excavation material. The best of the backfill material shall be used for backfilling within 2 feet of the structure. Just prior to placing backfill, the areas shall be cleaned of all excess construction material and debris and the bottom of excavations shall be in a thoroughly compacted condition.

**EARTHWORK**  
02200-9

2. Symmetrical backfill loading shall be maintained. Special care shall be taken to prevent any wedging action or eccentric loading upon or against the structures. During backfilling operations, care shall be exercised that the equipment used will not overload the structures in passing over and compacting these fills. Except as otherwise specified or directed, backfill shall be placed in layers not more than 12-inches in loose depth and each layer of backfill shall be compacted thoroughly and evenly using approved types of mechanical equipment. Each pass of the equipment shall cover the entire area of each layer of backfill.
3. In compacting and other operations, the Contractor shall conduct his operations in a manner to prevent damage to structures due to passage of heavy equipment over, or adjacent to, structures, and any damage thereto shall be made good by the Contractor at no additional expense to the Owner.
  - I. After backfilling trenches and excavations, the Contractor shall maintain the surfaces of backfill areas in good condition so as to present a smooth surface at all times level with adjacent surfaces. Any subsequent settling over backfilled areas shall be repaired by the Contractor immediately, in a manner satisfactory to the Engineer, and such maintenance shall be provided by the Contractor for the life of this Contract, at no additional expense to the Owner.
  - J. The finished subgrade of the fills and filled excavations upon which topsoil is to be placed, or pavements are to be constructed, or footings or slabs are to be constructed shall not be disturbed by traffic of other operations and shall be maintained in a satisfactory condition until the finished courses are placed. The storage or stockpiling of materials on finished subgrade will not be permitted.
  - K. Uniformly smooth grading of all areas to be graded, as indicated and as directed, including excavated and filled sections, embankments and adjacent transition areas, and all areas disturbed as a result of the Contractor's operations, shall be accomplished. The finished surfaces shall be reasonably smooth, compacted and free from surface irregularities.

### 3.2 COMPACTION

- A. Compaction Requirements: The degree of compaction is expressed as a percentage of the maximum dry density at optimum moisture content as determined by ASTM Test D1557, Method C. The compaction requirements are as follows:

AREA	ASTM DENSITY DEGREE OF COMPACTION
Below Footings & Slabs	95%
Pavement sub-base and access roads	95%
Root zone areas	85%-88%
Trench Backfill	
-below pavements	95%
-below general landscaped Areas	92%

### EARTHWORK 02200-10

-below structures and walls	95%
Other Areas	92%

B. Moisture Control:

1. Fill that is too wet for proper compaction shall be disced, harrowed, or otherwise dried to a proper moisture content to allow compaction to the required density. If fill cannot be dried within 24 hours of placement, it shall be removed and replaced with drier fill.
2. Fill that is too dry for proper compaction shall receive water uniformly applied over the surface of the loose layer. Sufficient water shall be added to allow compaction to the required density.

C. Unfavorable Conditions:

1. In no case shall fill be placed over material that is frozen. No fill material shall be placed, spread or rolled during unfavorable weather conditions. When work is interrupted by heavy rains, fill operations shall not be resumed until the moisture content and the density of the previously placed fill are as specified.
2. In freezing weather, a layer of fill shall not be left in an uncompacted state at the close of the day's operations. Prior to terminating work for the day, the final layer of compacted fill shall be rolled with a smooth wheeled roller to eliminate ridges of soil left by compaction equipment.

D. Compaction Control:

1. In-place density tests shall be made in accordance with ASTM D1556, D2922 or D2167 as the work progresses, to determine the degree of compaction being attained by the Contractor. Any corrective work required as a result of such tests, such as additional compaction, or a decrease in the thickness of layers, shall be performed by the Contractor at no additional expense to the Owner. Testing shall be made at the Contractor's expense by the geotechnical testing laboratory.
2. The Engineer's duties do not include supervision or direction of the actual work by the Contractor, his employees or agents. Neither the presence of the Engineer nor any observation and testing performed by him shall excuse the Contractor from defects discovered in his work at that time or subsequent to the testing.
3. In-place density tests shall be performed as a minimum according to the following frequency:
  - a. One test per lift under spread footings, or slabs.
  - b. One test per lift for every 100' length of strip footings or wall foundations.
  - c. A minimum of every 50 cubic yards of backfill in trenches or around structures, or beneath pavement

EARTHWORK  
02200-11

- d. One test every 500 cubic yards of material placed for general fill areas
4. Minimum laboratory testing requirements for granular fill and backfill materials are as follows:

Type of Test	Frequency	Testing Method
Grain Size Analysis (to the No. 200 Sieve)	1 test/1500 cy	ASTM D-422
Proctor Compaction Test	One test/source	ASTM D-1557

- a. The results of the initial tests shall be submitted to the Engineer for review at least 15 days prior to beginning of construction. The testing results shall indicate that the material meets the specified requirements.
- b. All other tests shall be performed during construction at the specified intervals or in the opinion of the Engineer, if the gradation of the materials changes. The samples obtained for testing shall be the newly placed backfill soils. The results shall be submitted to the Engineer for review prior to placement of overlay backfill material. The testing results shall indicate that the material meets the specific requirements.
- c. The rerun of the initial tests due to change of gradation of the backfill soils shall be performed by the Contractor at no additional expense to the Owner.

E. Placement:

- 1. Where the subgrade surface has an inclination of less than 4:1 (H:V), fill shall be placed in horizontal layers. Fill shall not be placed following the natural contours of the ground. Fill shall be placed starting in the lowest areas working up to finish grades in horizontal layers in the manner specified herein. Each layer of fill should be benched into the existing slope in order to avoid the formation of a shear plane.
- 2. When placing materials on slopes, the material can be compacted following the natural contours provided the materials are compacted to the requirements given in Paragraph 3.03.A of these specifications. Care should be exercised to avoid the formation of a smooth surface between layers of compacted soil. This may require that the Contractor scarify the top 2 to 3 inches of previously compacted material to permit shear transfer with the subsequent layer.

### 3.2 FINAL QUALITY CONTROL REPORT

- A. The Contractor shall submit a final quality control report presenting all of the results of the materials testing. The Contractor is responsible for compiling all of the quality control testing data into a formal report. The report shall be submitted within 15 days after the completion of all earthwork operations. The report shall include all test results including

### EARTHWORK 02200-12

laboratory compaction, field density, grain size analysis, and plans showing field density testing locations. The report shall be prepared and sealed by a Professional Engineer registered in the Commonwealth of Massachusetts.

### 3.4 FINE GRADING

- A. Before surface or subbase is spread, the subgrade shall be shaped to a true surface conforming to the Drawings. All depressions and high spots shall be filled with suitable material or removed and such areas again compacted until the surface is smooth and properly compacted. A tolerance of ½ inch above or below the finished subgrade will be allowed provided that this ½ inch above or below grade is not maintained for a distance longer than 50 feet and that the required crown is maintained in the subgrade. Any portion which is not accessible to a roller shall be thoroughly compacted by other mechanical methods.

END OF SECTION 02200

EARTHWORK  
02200-13



## SECTION 02212

### ROCK EXCAVATION

#### PART 1 -GENERAL

##### 1.1 SUMMARY

- A. Rock excavation may be required where boulders, monolithic concrete, reinforced concrete or stone structures measuring in excess of two cubic yards solid in volume or larger are encountered or solid ledge which, in the opinion of the Engineer, requires drilling and blasting, wedging, sledging, barring, or hydraulically fracturing for removal, is encountered.
- B. The following do not constitute rock excavation: hardpan; soft or disintegrated rock; concrete which can be removed with a pick; previously blasted rock or broken stone less than the above mentioned two cubic yards; stone walls; rocks or sections of blasted ledge that may fall into or be jarred loose from the sides of the trench beyond the maximum limits of excavation approved by the Engineer.
- C. The blasting shall be accomplished by an experienced technician and the Contractor or Sub-Contractor shall be conducted in accordance with 527 CMR 13.00. The Contractor will procure the proper blasting permit from the City of Waltham Fire Department and shall acknowledge all the contents and laws of the State Fire Marshall in handling, using, storing and transporting explosives and caps. Blasting shall be conducted with all possible care so as to avoid injury to persons and property. The rock shall be well covered with suitable mats or heavy logs chained together or other such effective appliances; Sufficient warning shall be given to all persons in the vicinity of the work before blasting. Extreme care shall be taken to avoid injury to water mains and services, gas pipes, sewers, drain ducts, cables and other structures.
- D. In addition to adhering to all the laws and ordinances relating to the handling and storage of explosives, the Contractor shall also conform to any further regulations deems necessary by the Fire Department Chief and the Engineer and be aware of any inspection fees as required by the fire department.

##### 1.2 SCOPE OF WORK

- A. Furnish all labor, materials, equipment, and incidentals required to excavate and dispose of rock boulders as shown on the Drawings and as specified herein.
- B. Blasting permits are the responsibility of the Contractor. All applications and fees shall be provided by the Contractor. When permits have been obtained, blasting may be used to fracture rock and boulders for excavation. If blasting is performed, provide the services of a qualified blasting technician, licensed in Massachusetts.
- C. All arrangements for inspections required by the Waltham Fire Department shall be made by the Contractor.

### ROCK EXCAVATION

02212-1

### 1.3 RELATED WORK

- A. Earth excavation and backfilling are included in Section 02221.
- B. Environmental Protection is included in Section 01110.

### 1.4 SUBMITTALS

- A. Submit three copies of blasting permits required by local agencies and authorities. Original permits shall be prominently displayed on the Work site prior to initiating blasting operations. Submittals shall be for information only. Contractor shall remain responsible for means, methods, and techniques, as well as all safety considerations.
- B. All blasting shall be in accordance with 527 CMR 13.00.
- C. The cost for all photographs and/or pre-blast videotapes shall be included in the bid price.
- D. The cost for inspection, shall be paid directly to the Waltham Fire Department. All fees for inspection shall be included in the blasting cost.

### 1.5 DELIVERY, STORAGE, AND HANDLING

- A. The delivery, storage, and handling of explosives shall be performed only by qualified persons licensed in Massachusetts, and shall be in full conformance with all laws, regulations, ordinances, and practices. Extreme care shall be taken to avoid injury or damage to persons or property.

### 1.6 DEFINITIONS

- A. Rock: Any large mass of stone, bedrock, or ledgerrock.
- B. Boulder: Rock fragments not exceeding two cubic yards in volume.
- C. Rock Excavation: The removal of solid rock or rock fragments greater than two cubic yards in volume which cannot be removed by conventional mechanical excavation equipment or without continuous, systematic drilling blasting.
- D. Boulder Excavation: The Removal of boulders not exceeding two cubic yards in volume which can be excavated without by conventional mechanical excavation equipment or without continuous, systematic drilling and blasting.

## PART 2 – PRODUCTS

### 2.1 MATERIALS

- A. Gravel fill shall be as specified in Section 02230.

### ROCK EXCAVATION 02212-2

## PART 3 -EXECUTION

### 3.1 PREPARATION FOR BLASTING

- A. A pre-blast survey shall be conducted for all structures within the influence range of blasting operations, or within 250-ft of the blast area, whichever is greater. The pre- blast survey shall consist of a close visual inspection, fully supported by photographs or video recordings, performed by, or under the supervision of, a licensed professional engineer or geologist experienced in such surveys. The Contractor's insurance underwriter shall be present during such surveys.
- B. Any damage noted after completion of blasting operations which cannot be determined from the pre-blast survey to be a pre-existing condition shall be presumed to have been caused by blasting operations. Such damage shall be repaired promptly and completely to the property owner's satisfaction to restore the condition of the property to that existing prior to blasting.
- C. Pre-blast survey records shall be maintained for a period of not less than three years following final completion and acceptance of the Work.

### 3.2 BLASTING PLANS

- A. Prior to initiating blasting operations, a blasting plan shall be prepared as required by the Waltham Fire Department. The plan may include sketches to show blast locations; proximity to, and methods for protection of, existing structures and utilities; drill hole patterns, amount of charges, firing sequence and times; calculations of ground velocities, energy ration, acceleration and displacement; and any other pertinent information required. Field monitoring methods and techniques shall also be addressed.
- B. If required by local or state regulations, blasting plans shall be reviewed by the appropriate agency or authority and revised as required to meet with their approval.

### 3.3 BLASTING

- A. Blasting operations shall be performed under the direct supervision of a qualified blasting technicians licensed in Massachusetts. Blasting operations shall be in full compliance with applicable state and local laws, regulations, ordinances and practices.
- B. Blast locations shall be heavily matted to contain potential flying debris.

### 3.4 BOULDER EXCAVATION

- A. Boulders and rock fragments up to two cubic yards in volume may be reduced in size by rock excavation methods to simplify its removal.

## ROCK EXCAVATION 02212-3

### 3.5 TRENCH PROCEDURE

- A. Excavate rock in pipe trenches, before laying pipe, to no less than 6 in. from pipe. Backfill trench, before pipe is laid, to correct subgrade. Use thoroughly compacted, suitable material or, when so specified or indicated on drawings, same material as required for bedding pipe. Furnish and place at no additional compensation.
- B. Fill excess excavation below elevation of the top of bedding, cradle, or envelope when in pipe trenches with material of same type and placed and compacted in same manner as specified for bedding, cradle, or envelope.
- C. At option of Contractor, fill excess excavation in rock beneath foundations with Class A or Class B concrete.
- D. Drill and blast a single line of holes in vertical face of rock at end of trench, when shattering rock at ends of pipe or elsewhere as indicated. Provide minimum depth drillholes of 4 ft. and maximum spacing of 18 in. centers. Use sufficient explosive to shatter rock for future excavation. Complete shattering before any pipe or fitting is placed within 50 ft. of rock to be shattered.
- E. Remove shattered rock. If rock below normal depth is shattered due to drilling or blasting operations of Contractor and Engineer considers such shattered rock to be unfit for foundations, remove it and backfill excavation with concrete as required, except that in pipe trenches, use screened gravel for backfill. Do such removal and backfilling at no additional compensation.
- F. Remove dirt and loose rock, as directed, from designated areas and clean surface of rock thoroughly, using steam to melt snow and ice, if necessary. Remove water in depressions, so that whole surface of designated area can be inspected to determine whether seams or other defects exist.
- G. Rough surfaces of rock foundations sufficiently to bond well with masonry and embankments to be built thereon and, if required, cut to rough benches or steps.
- H. Remove from the rock surface to remain all vegetation, dirt, sand, clay, boulders, scale, excessively cracked rock, loose fragments, ice, snow, and other objectionable substances. Use picking, barring, wedging, streams of water under sufficient pressure, stiff brushes, hammers, steam jets, and other effective means to accomplish this cleaning, and remove free water left on the surface or rock. Perform all of above before any masonry embankment is built on or against rock.
- I. Remove piles of boulders or loose rock encountered within limits of earth embankments to a suitable place of disposal.
- J. Use excavated rock in backfilling trenches subject to following limitations:
  - 1. Do not use pieces of rock larger than permitted by Engineer.

### ROCK EXCAVATION 02212-4

2. Do not allow rock quantities used in backfill in any location to result in formation of voids.
  3. Do not place rock backfill within 16 in. of surface of finish grade.
- K. Backfill with material obtained from outside sources at no additional compensation, when material suitable for backfilling is not available in sufficient quantity from other excavations.

### 3.6 DISPOSAL OF ROCK AND BOULDERS

- A. Fragmented rock with dimensions not exceeding 6-in. in any direction may be mixed with common fill (providing compaction requirements will not be compromised) and used as common fill in accordance with Section 02221.
- B. Fragmented rock up to 12-in in length in any direction may be used as riprap or slope stabilization, provided that such materials meet the requirements for riprap and slope stabilization specified in Section 02221.
- C. Rock and boulders may be crushed and screened for reuse in the Work, provided that the resultant materials meet the requirements for gravel, crushed stone, or structural fill as specified in Section 02221.
- D. Unused rock and boulders shall be removed and disposed of off-site.

END OF SECTION 02212

### ROCK EXCAVATION 02212-5

## SECTION 02221

### TRENCHING, BACKFILLING AND COMPACTION

#### PART 1 GENERAL

##### 1.1 SCOPE OF WORK

- A. Furnish all labor, materials, equipment and incidentals necessary to perform all trenching for pipelines and appurtenances, including drainage, filling, backfilling, disposal of surplus material and restoration of trench surfaces and easements.
- B. Excavation shall extend to the width and depth shown on the Drawings and or as specified and shall provide suitable room for installing pipe, structures and appurtenances.
- C. The Contractor shall furnish and place all sheeting, bracing and supports and shall remove from the excavation all materials which the Engineer may deem unsuitable for backfilling. The bottom of the excavation shall be firm, dry and in all respects, acceptable to receive the work. Work shall not be placed on frozen ground nor shall work be placed on wet unstable ground. If conditions warrant, the Contractor may be ordered to deposit gravel for pipe bedding, or gravel refill for excavation below grade, directly on the bottom of the trench immediately after excavation has reached the proper depth and before the bottom of the trench has become softened or disturbed by any cause whatever. The length of open trench shall be related closely to the rate of pipe laying. All excavation shall be made in open trenches.
- D. All excavation, trenching, and related sheeting, bracing, etc. shall comply with the requirements of OSHA excavation safety standards (29 CFR Part 1926.650 Subpart P) and State requirements. Where conflict between OSHA and State regulations exists, the more stringent requirements shall apply.
- E. Wherever the requirement for 92 percent compaction is referred to herein it shall mean "at least 92 percent of maximum density as determined by ASTM D1557, Method C". Backfilling operations shall be such that material is compacted in 6 inch lifts, including the trench around the barrel of the pipe. Care shall be taken as to not place excessive pressure on the new pipe, such as using heavy rubber tire equipment as a compaction method directly over the new pipe.
- F. Contractor will hand dig around existing utilities.
- G. Excavation shall be protected each day by either backfilling or steel plates as required.
- H. Abandoned pipes and structures are to be completely removed or sealed.

### TRENCHING, BACKFILLING AND COMPACTION

## 1.2 RELATED WORK

- A. Rock and boulder excavation is included in Section 02212.
- B. Granular fill materials is included in Section 02200.
- C. Dewatering and Drainage is included in Section 02140.
- D. Pavement repair and resurfacing is included in Section 02576.

## 1.3 DEFINITIONS

- A. Percentage of compaction is defined as the ratio of the field dry density, as determined by ASTM D1556 or ASTM D2922 to the maximum dry density determined by ASTM D1557 Method C, multiplied by 100.
- B. Proof Roll: Compaction with a minimum of 4 passes of a vibratory steel drum or rubber tire roller. Vibratory plate compactors shall be used in small areas where vibratory steel drum or rubber tire roller cannot be used.
- C. Acceptable Material: Material which does not contain organic silt or organic clay, peat, vegetation, wood or roots, stones or rock fragments over 6-inch [15 cm] in diameter, porous biodegradable matter, loose or soft fill, excavated pavement, construction debris, or refuse. Stones or rock fragments shall not exceed 40 percent by weight of the backfill material.
- D. Unacceptable Materials: Materials that do not comply with the requirements for the acceptable material or which cannot be compacted to the specified or indicated density.

## 1.4 SUBMITTALS

- A. Shop Drawings: Submit the following in accordance with Section 01300 - SUBMITTAL PROCEDURES:
  - 1. Qualifications of the Contractor's Independent Testing Laboratory as specified in Paragraph 1.5 I, two (2) weeks prior to the execution of any earth excavation, backfilling, filling, or compaction process.
  - 2. Submit an excavation, backfilling, and filling plan at least one week prior to start of any earth moving activities. The review will be only for the information of the Owner and third parties for an overall understanding of the project relating to access, maintenance of existing facilities and proper utilization of the site. The Contractor shall remain responsible for the adequacy and safety of the means, methods and sequencing of construction. The plan shall include, but not be limited to the following items:

### TRENCHING, BACKFILLING AND COMPACTION

02221-2

- a. Detailed sequence of work.
  - b. General description of construction methods.
  - c. Numbers, types, and sizes of equipment proposed to perform excavation and compaction.
  - d. Details of dust control measures.
  - e. Proposed locations of stockpiled excavation and/or backfill materials.
  - f. Proposed surplus excavated material off-site disposal areas and required permits.
  - g. Details of erosion and sedimentation control measures which will prevent erosion and sedimentation during the earth moving activities.
3. The following material submittals shall be submitted to the Engineer prior to backfilling and filling:
- a. Gravel Borrow as specified in Section 02230.
  - b. Bank-run Gravel as specified in Section 02230.
  - c. Crushed Stone as specified in Section 02230.
  - d. Other Acceptable Materials: Laboratory testing results of gradation and moisture-density relationship. Submittal shall include specific location of the source and the date when sample was taken.
4. During Construction, submit written confirmation of fill lift thickness, in- place soil moisture content, and percentage of compaction to the Engineer before placing the next lift or constructing foundations.
5. Controlled Density Fill Mix Design:
- a. Prior to beginning the work the Contractor shall submit for review, flowable fill mix designs which shall show the proportions and gradations of all materials for each class and type of flowable fill specified

## 1.5 QUALITY ASSURANCE

- A. Provide in accordance with Section 01400 and as specified.
- B. Dewatering and Groundwater Control: Provide and maintain as specified in Section 02140.

## TRENCHING, BACKFILLING AND COMPACTION

02221-3



- C. Excavations shall be performed in the dry, and kept free from standing water, snow and ice during construction. Bedding and backfill material shall not be placed in water. Water shall not be allowed to rise upon or flow over the bedding and backfill material
- D. The Contractor shall be solely responsible for making all excavations in a safe manner. All excavation, trenching, and related sheeting, bracing, etc. shall comply with the requirements of OSHA excavation safety standards (29 CFR Part 1926 Subpart P) and State requirements. Where conflict between OSHA and State regulations exists, the more stringent requirements shall apply.
- E. Do not excavate, construct embankments, or fill until all the required submittals have been reviewed by the Engineer.
- F. Formulate excavation, backfilling, and filling schedule and procedures to eliminate possibility of undermining or disturbing foundations of partially and completed structures, pipelines and embankments or existing structures and pipelines.
- G. Employ an independent testing laboratory to perform particle size and gradation analyses in accordance with ASTM D422, and to determine compactibility in accordance with ASTM D1557 for all the proposed backfill and fill materials, and monitoring field compaction operations. The independent testing laboratory shall have the following qualifications:
  - 1. Be accredited by the American Associates of State Highway and Transportation Officials (AASHTO) Accreditation Program.
  - 2. Have three (3) years experience in sampling, testing and analysis of soil and aggregates, and monitoring field compaction operations.
  - 3. Able to provide three (3) references from previous work.
- H. Field Testing and Inspections:
  - 1. By (Owners testing laboratory or Contractor's independent testing laboratory, acceptable to the Engineer, at Contractor's expense) as specified.
  - 2. Location of tests mutually acceptable to testing laboratory and the Engineer or as directed by the Engineer.
  - 3. In the event compacted material does not meet specified in-place density, recompact material and retest this area until specified results are obtained at no additional cost to the Owner.
  - 4. Testing laboratory to perform inspection at least once daily to confirm lift thickness and compaction effort for entire fill area.

## TRENCHING, BACKFILLING AND COMPACTION

- I. Methods of Field Testing:
  - 1. In-Place Density: ASTM D1556, ASTM D2167, or ASTM D2922.
  - 2. In-Place Moisture Content: ASTM D3017, ASTM D4944, or ASTM D4959.
  
- J. Material Testing Frequency: The following testing frequencies are minimum required for all structural and non-structural fill, grading and embankment
  - 1. Field In-Place Density and Moisture Content - Screened gravel and crushed stone shall be compacted as specified and indicated. For other backfill and fill materials, minimum test frequency shall be as follows, and no less than one test per lift:
    - a. Trenches under structures foundation preparation or roadways subbase: Every 100 lin. ft. [30 m.] per lift.
    - b. Trenches in areas without structures or roadways: Every 250 lin. ft. [60 m.] per alternate lift.
    - c. Paved Roadways: Every 100 lin. ft. [30 m.] per lift.
    - d. Paved Areas: 2,000 sq. ft. [185 sq. m.] per lift.
    - e. Under Structure: 1,000 sq. ft. [100 sq. m.] per lift.
    - f. Around Structures: 1,500 sq. ft. [150 sq. m.] per lift.
    - g. Embankment Fills: 5,000 sq. ft. [465 sq. m.] per lift.
  - 2. Moisture Density - One per source, except for screened gravel and crushed stone. Repeat the moisture density test for every 1,000 cubic yard of material use, and whenever visual inspection indicates a change in material gradation as determined by the Engineer.
  - 3. Gradation Analysis – A minimum of one per source and for each moisture density test and whenever visual inspection indicates a change in material gradation.
  - 4. Liquid Limit, Plastic Limit and Plasticity Index - Minimum of one test per 500 cubic yard [382cubic meter] of soil for use as fill material and whenever classification of material is in doubt as determined by the Engineer.

## TRENCHING, BACKFILLING AND COMPACTION

02221-5

- K. Construction Tolerances
1. Construct finished surfaces to plus or minus 1 inch [2.5 cm] of the elevations
  2. Grade cut and fill areas to plus or minus 0.20 foot [6.0 cm] of the grades indicated.
  3. Complete embankment edges to plus or minus 6 inches [15 cm] of the slope lines indicated.
  4. Provide the Engineer with adequate survey information to verify compliance with above tolerances.
- L. Cut pavement with a saw or pneumatic tools to prevent damage to remaining pavement without extra compensation. Where pavement is removed in large pieces, dispose of pieces before proceeding with excavation.
- M. Pipes, drains, and other utilities may exist in certain locations not indicated on drawings. No attempt has been made to show all services. Completeness or accuracy of information given is not guaranteed.
- N. Carefully support and protect from damage, existing pipes, poles, wires, fences, curbing, property line markers, and other structures, which the Engineer determines must be preserved in place without being temporarily or permanently relocated. Should such items be damaged, restore without compensation therefor, to at least as good condition as that in which they were found immediately before the work was begun.
- O. Whenever certain existing structures, as described below, are encountered, and the Engineer so directs, change the location, remove and later restore, or replace such structures, or assist the Owner in doing so. Such work to be paid for under applicable items of work, otherwise as Extra Work.
- P. In removing existing pipes or other structures, include for payment only those new materials which are necessary to replace those unavoidably damaged as determined by the Engineer.
- Q. The preceding two paragraphs apply to pipes, wires, and other structures which meet the following: (a) are not indicated on the drawings or otherwise provided for, (b) encroach upon or are encountered near and substantially parallel to the edge of the excavation, and (c) in the opinion of the Engineer, will impede progress to such an extent that satisfactory construction cannot proceed until they have been changed in location, removed (to be later restored), or replaced.
- R. Restore existing property or structures as promptly as practicable.
- S. If material is unacceptable for foundation support (in the opinion of the Engineer) is found at or below the grade to which excavation would normally be carried in

#### TRENCHING, BACKFILLING AND COMPACTION

accordance with the drawings and/or specifications, remove such material to the required width and depth as directed by the Engineer and replace it with gravel borrow, crushed stone, or concrete.

- T. Do not remove excavation materials from the site of the work or dispose of except as directed or permitted by the Engineer.
- U. Provide suitable and safe bridges and other crossings where required for accommodation of travel, and to provide access to private property during construction, and remove said structures thereafter.

## PART 2 PRODUCTS

### 2.1 GENERAL

- A. Use only acceptable materials from excavations or borrows, as determined by the Engineer.
- B. Provide 3,000 psi [20 MPa] concrete, bank-run gravel, gravel borrow, and crushed stone.
- C. Provide Fine Aggregate conforming to ASTM C33.
- D. Provide erosion/sedimentation control devices as indicated, including geotextile fabric in accordance with Section 01110.
- E. Provide geotextile fabric and silt fence as indicated, .
- F. Provide erosion/sedimentation control devices as indicated, including geotextile fabric in accordance with Section 01110.

## PART3 EXECUTION

### 3.1 TRENCH EXCAVATION

- A. Pavement shall be cut with a saw, or wheel along straight lines before excavating.
- B. Trenches shall be excavated to sufficient depths and to sufficient widths for installing new pipe/components where required, placing and removing of decking, sheeting and bracing, and for pumping and drainage facilities. The bottom of the excavations shall be firm and dry and in all respects acceptable to the Engineer. Trench width shall be a practical minimum, as needed for proper execution for the work.
- C. Trench excavation shall include material of every description and of whatever substance encountered, except rock and boulders. Trench excavation shall also include removal of existing reinforced concrete subbase, if encountered.
- D. The Contractor shall strip and stockpile excavated trench materials. Any bushes that are removed shall be protected and replanted in the same location. Removed curbing shall be

### TRENCHING, BACKFILLING AND COMPACTION

stockpiled in a safe manner. Where grassed areas are disturbed by stockpiled materials, the Contractor shall rake out the area and loam and re-seed at his expense.

- E. Stockpiling of materials shall be included in the pay items for excavating and no Allowances shall be made for any stripping and stockpiling requirements.
- F. While excavating and backfilling is in progress, traffic shall be maintained, and all utilities and other property protected as provided in the General Conditions and General Requirements.
- G. Trenches shall be excavated to the depth indicated on the Drawings and in widths sufficient for laying the pipe, bracing and for pumping and drainage facilities. The bottom of the excavations shall be firm and dry and in all respects acceptable to the Engineer. Trench width shall be practical minimum.
- H. Excavation and dewatering shall be accomplished by methods which preserve the undisturbed state of subgrade soils. The trench may be excavated by machinery to, or just below the designated subgrade, provided that material remaining in the bottom of the trench is no more than slightly disturbed. Subgrade soils which become soft, loose, "quick", or otherwise unsatisfactory as a result of inadequate excavation, dewatering or other construction methods shall be removed and replaced by gravel borrow as required by the Engineer at the Contractor's expense.
- I. Clay and organic silt soils are particularly susceptible to disturbance due to construction operations. When excavation is to end in such soils, the Contractor shall use a smooth-edge bucket to excavate the last one foot of depth.
- J. Where pipe is to be laid in crushed stone, the trench may be excavated by machinery to the normal depth of the pipe plus the depth of the stone, provided that the material remaining in the bottom of the trench is no more than slightly disturbed.
- K. Where pipe is to be laid directly on the trench bottom. final excavation at the bottom of the trench shall be performed manually, providing a flat-bottom true to grade upon undisturbed material. Bell holes shall be made as required.
- L. Excavate trenches to depths so as to permit pipe to be laid at elevations, slopes, or depths of cover indicated on drawings, and at uniform slopes between indicated elevations. .
- M. Make pipe trenches as narrow as practicable and do not widen by scraping or loosening materials from the sides. Make every effort to maintain sides of trenches firm and undisturbed until backfilling has been placed and compacted.
- N. Excavate trenches with approximately vertical sides between springline of pipe and elevation 1 ft. [30 cm] above top of pipe.

## TRENCHING, BACKFILLING AND COMPACTION

### 3.2 DISPOSAL OF MATERIALS

- A. Excavated material shall be stacked without excessive surcharge on the trench bank or obstructing free access to hydrants and gate valves. Inconvenience to traffic and abutters shall be avoided as much as possible. Excavated material shall be segregated for use in backfilling as specified below.
- B. It is expressly understood that no excavated material shall be removed from the site of the work or disposed of by the Contractor except as directed by the Engineer. When removal of surplus materials has been approved by the Engineer, the Contractor shall dispose of such surplus material in approved areas designated by the Contractor.
- C. Should conditions make it impracticable or unsafe to stack material adjacent to the trench, the material shall be hauled and stored at a location provided by the Contractor. When required, it shall be re-handled and used in backfilling the trench.
- D. All cost of handling, storing and rehandling excavated materials shall be included in the respective unit bid in the Bid Form for the installation of new water main.

### 3.3 SHEETING AND BRACING

- A. Furnish, put in place and maintain sheeting and bracing required by Federal, State or local safety requirements to support the sides of the excavation and prevent loss of ground which could endanger personnel, damage or delay the work or endanger adjacent structures. If the Engineer is of the opinion that at any point sufficient or proper supports have not been provided, he/she may order additional supports placed at the expense of the Contractor. Compliance with such order shall not relieve the Contractor from his/her responsibility for the sufficiency of such supports. Care shall be taken to prevent voids outside of the sheeting, but if voids are formed, they shall be immediately filled and rammed.
- B. When moveable trench bracing such as trench boxes; manhole boxes, moveable sheeting, shoring or plates are used to support the sides of the trench, care shall be taken in placing and moving the boxes or supporting bracing to prevent movement of the pipe, or disturbance of the pipe bedding and the screened gravel backfill.
- C. When installing pipe; trench boxes, moveable sheeting, shoring or plates shall not be allowed to extend below mid-diameter of the pipe. As trench boxes, moveable sheeting, shoring or plates are moved, screened gravel shall be placed to fill any voids created and the screened gravel and backfill shall be recompact to provide uniform side support for the pipe.
- D. All excavations within the right-of-way of streets shall be sheeted and braced. Sheeting and bracing shall be adequate to support decking and to meet the requirements of applicable general laws and regulations.
- E. The Contractor will be permitted to use steel sheeting in lieu of wood sheeting for the entire job wherever the use of sheeting is necessary. The cost for use of sheeting will be

### TRENCHING, BACKFILLING AND COMPACTION

included in the bid items for pipe and shall include full compensation for driving, bracing and later removal of sheeting.

- F. All sheeting and bracing shall be carefully removed in such manner as not to endanger the construction of other structures, utilities, or property, whether public or private. All voids left after withdrawal of sheeting shall be immediately refilled with sand by ramming with tools especially adapted to that purpose, by watering or otherwise as directed.
- G. The Contractor shall receive no payment, for sheeting, bracing, etc., during the progress of the work. The Contractor shall receive no payment for sheeting which has actually been left in the trench for the convenience of the Contractor.
- H. Sheeting driven below mid-diameter of any pipe shall remain in place from the driven elevation to at least 1-ft above the top of the pipe.

### 3.4 TEST PITS

- A. The Contractor may be required to excavate test pits for the purpose of locating underground utilities or structures as an aid in establishing the precise location of new work.
- B. Test pits shall be backfilled as soon as the desired information has been obtained. The backfilled surface shall be maintained in a satisfactory condition for travel until resurfaced as specified.

### 3.5 EXCAVATION BELOW GRADE AND REFILL

- A. Whatever the nature of unstable material encountered or the groundwater conditions, trench drainage shall be complete and effective.
- B. If the Contractor excavates below grade through error or for his/her own convenience, or through failure to properly dewater the trench, or disturbs the subgrade before dewatering is sufficiently complete, he/she may be directed by the Engineer to excavate below grade as set forth in the following paragraph, in case the work of excavating below grade and furnishing and placing the refill shall be performed at his/her own expense.

If the material at the level of trench bottom consists of fine sand, sand and silt or soft earth which may work into the screened gravel notwithstanding effective drainage, the subgrade material shall be removed to the extent directed and the excavation refilled with a 6-in layer of crushed stone as approved by the Engineer, to form a filter layer preserving the voids in the gravel bed of the pipe. The composition and gradation of gravel shall be approved by the Engineer prior to placement. Screened gravel shall then be placed in 6-in. layers thoroughly compacted up to the normal grade of the pipe. If directed by the Engineer, bank-run gravel shall be used for refill of excavation below grade.

- D. Geotextile filter fabric may be substituted for filter layer if approved by the Engineer.

### TRENCHING, BACKFILLING AND COMPACTION

Filter fabric shall be Mirafi 140N, Supac equivalent, or equal.

### 3.6 BACKFILLING

- A. As soon as practicable after the pipe has been laid and jointed and inspected by the Engineer, backfilling shall begin and thereafter be prosecuted expeditiously. Bedding gravel, as specified for the type of pipe installed, shall be placed up to 1-ft over the pipe.
- B. An impervious dam or bulkhead cutoff of clay or other impervious material shall be constructed in the trench as directed, to interrupt the unnatural flow of groundwater after construction is completed. The dam shall be effectively keyed into the trench bottom and sidewalls. Provide at least one clay or other impervious material dam in the pipe bedding between each manhole where directed or every 300 feet, whichever is less.
- C. Where the pipes are laid in streets, the remainder of the trench up to a depth of 1-ft below the bottom of the specified permanent paving shall be backfilled with common fill material in layers not to exceed 1-ft and thoroughly compacted. The subbase layer for paving shall be of bank-run gravel thoroughly compacted in 6-in layers.
- D. To prevent longitudinal movement of the pipe, dumping backfill material into the trench and then spreading will not be permitted until selected material or screened gravel has been placed and compacted to a level 1-ft over the pipe.
- E. Backfill shall be brought up evenly on all sides. Each layer of backfill material shall be thoroughly compacted by rolling, tamping, or vibrating with mechanical compacting equipment or hand tamping, to 92 percent compaction. If rolling is employed, it shall be by use a suitable roller or tractor, being careful to compact the fill throughout the full width of the trench.
- E. Backfilling and filling operations shall be suspended in areas where test are being Made until tests are completed and the testing laboratory has advised the Engineer That adequate densities are obtained.
- E. Water jetting or puddling may be used unless the refill contains too great a proportion of clay or loam to permit satisfactory drying. Water jetting shall consist of using a suitable length of pipe at least 1-1/4 in in diameter fitted with quick acting valve and sufficient hose to connect to hydrant or pump having adequate pressure and capacity. The full depth of backfill shall be thoroughly inundated by thrusting the pipe into the fill at frequent intervals with the valve open until all slumping ceases. Where backfill is compacted by puddling, it shall be done by depositing in water. Water for jetting or puddling may be obtained from Owner hydrants wherever possible. Water may be furnished by the Owner from these hydrants if reasonable care is exercised in its use and when approved by the Water Department.
- G. If water restrictions are in force, the Contractor shall obtain his/her own water elsewhere, or compact the backfill by other approved methods at no additional cost to this Contract.

### TRENCHING, BACKFILLING AND COMPACTION



- H. Where other methods are not practicable, compaction shall be by use of hand or pneumatic ramming with tools weighing at least 20 lbs. The material being spread and compacted in layers not over 6-in thick. If necessary, sprinkling shall be employed in conjunction with rolling or ramming.
- I. Backfill around structures shall be selected common fill material, may be compacted by puddling where approved by the Engineer. All backfill shall be compacted, especially under and over pipes connected to the structures.
- J. Subject to the approval of the Engineer, fragments of ledge and boulders smaller than 6-in may be used in trench backfill providing that the quantity in the opinion of the Engineer, is not excessive. Rock fragments shall not be placed until the pipe has at least 2-ft of earth cover. Small stones and rocks shall be placed in thin layers alternating with earth to insure that all voids are completely filled. Fill shall not be dropped into the trench in a manner to endanger the pipe.
- K. Bituminous paving shall not be placed in backfilling unless specifically permitted, in which case it shall be broken up as directed. Frozen material shall not be used under any circumstances.
- L. All road surfaces shall be broomed and hose-cleaned immediately after backfilling. Dust control measures shall be employed at all times.

### 3.7 RESTORING TRENCH SURFACE

- A. Where the trench occurs adjacent to paved streets, in shoulders, sidewalks, or in cross-country areas, the Contractor shall thoroughly consolidate the backfill and shall maintain the surface as the work progresses. If settlement takes place, he/she shall immediately deposit additional fill to restore the level of the ground.
- B. In and adjacent to streets, the top 12-in layer of trench backfill shall consist of compacted bank-run gravel. Should the Contractor wish to use material excavated from the trench as gravel subbase for pavement replacement, the Contractor shall at his/her own expense have samples of the material tested by an independent testing laboratory at intervals not to exceed 500 feet, in order to establish its compliance with the specifications. Only material which has been tested by the Contractor and approved by the Engineer shall be allowed to be incorporated into the work.
- C. The surface of any driveway or any other area which is disturbed by the trench excavation and which is not a part of the paved road shall be restored by the Contractor to a condition at least equal to that existing before work began.

### 3.8 PROTECTION

- A. Curbing, fencing, sign posts, utility poles, mailboxes, etc. in the vicinity of the Contractor's operations shall be adequately protected, and if necessary removed and restored after backfilling. All items which are damaged during construction shall be replaced with material fully equal to that existing prior to construction. Where curbing or

#### TRENCHING, BACKFILLING AND COMPACTION

throatstones are to be removed and not replaced, the curb pieces shall be brought to the Waltham Department of Public Works yard and deposited near the curbing laydown area.

- B. Enclose uncut tree trunks adjacent to work in wooden boxes of such height as may be necessary for protection from injury from piled material, equipment, operations, or otherwise due to work. Operate excavating machinery and cranes of suitable type with care to prevent injury to trees not to be cut and particularly to overhanging branches and limbs.
- C. Cut all branches, limbs, and roots smoothly and neatly without splitting or crushing. Neatly trim, cut the injured portions and cover with an application of grafting wax or tree healing paint as directed.
- D. Protect cultivated hedges, shrubs, and plants which might be injured by the Contractor's operations by suitable means or dig up and temporarily replant and maintain. After construction operations have been substantially completed, replant in original positions and care for until growth is reestablished. If cultivated hedges, shrubs, and plants are injured to such a degree as to affect their growth or diminish in their beauty or usefulness, replace by items of equal kind and quality existing at the start of the work.
- E. Do not use or operate tractors, bulldozers, or other power-operated equipment on paved surfaces when their treads or wheels which are so shaped as to cut or otherwise damage such surfaces.
- F. Restore surfaces damaged by the Contractor's operations to a condition at least equal to that in which they were found immediately before work commenced. Use suitable Materials and methods for such restoration.

### 3.9 DUST CONTROL

- A. Calcium Chloride shall be uniformly applied by hand methods or by approved spreading devices as directed by the Engineer. The Contractor shall have a nominal supply of Calcium Chloride on hand at all times.

END OF SECTION 02221

## TRENCHING, BACKFILLING AND COMPACTION

## SECTION 02222

### CLEARING AND GRUBBING

#### PART 1-GENERAL

##### 1.1 SCOPE OF WORK

- A. This work shall consist of clearing, grubbing, cutting, removal and disposal of all vegetation and debris from areas either within or outside of the right-of-way as shown on the drawings or as designated by the Engineer. The work shall also include the preservation from injury or defacement of all vegetation and objects designated by the Engineer to remain.

#### PART 2-PRODUCTS (NOT USED)

#### PART 3-EXECUTION

##### 3.1 GENERAL

- A. The burning of trees, brush, stumps, etc., will not be permitted. The Contractor shall provide other satisfactory methods of disposal without additional compensation.
- B. The Contractor shall obtain written permission of the Engineer for use of storage areas within the right-of-way requiring clearing and grubbing or selective clearing and thinning. Any clearing for the Contractor's convenience shall be done at his own expense. All such areas shall be restored to a condition acceptable to the Engineer including necessary mulching, seeding, and planting without additional compensation.
- C. The Engineer shall be provided with notarized copies of agreements between the Contractor and owners used as disposal or storage areas.
- D. When fencing is installed outside normal clearing areas, every reasonable effort shall be made to preserve trees or shrubs whose removal is not essential to the installation of the fencing.
- E. Acceptable material obtained on the project may be used to produce wood chip mulch. Material obtained from Elm trees shall not be accepted for use.
- F. Wood chips produced from clearing and grubbing shall be stockpiled within the location and used where and as directed.
- G. Except for materials used for making wood chip mulch, the Contractor shall make all arrangements and negotiations necessary for the satisfactory disposal of trees, shrubs, stumps, roots, dead wood and other litter, in areas outside the Right of Way

### CLEARING AND GRUBBING

02222-1

and in such manner that no condition or accumulation of material shall be permitted to disfigure or mar the finished landscape.

### 3.2 CLEARING AND GRUBBING

- A. The stumps of all trees, brush and major roots shall be grubbed and removed in all excavation areas and under all embankments where the original ground level is within 3-1/2 feet of the subgrade or slope of embankments.
- B. All trees, stumps, and brush shall be cut off within 6 inches of the ground in embankment areas where the original ground level is more than 3-1/2 feet below the subgrade or slope of embankments.
- C. Trees and shrubs that are specifically designated by the Engineer not to be cut, removed, destroyed or trimmed shall be saved from harm and injury.
- D. All damage done to trees by the Contractor's operation and all branches of trees extending within the roadway shall be trimmed and painted where cut as directed to provide a 20-foot minimum vertical clearance including selective trimming of such trees as directed.

### 3.3 SELECTIVE CLEARING AND THINNING

- A. The work under this item shall consist of the removal of hazardous growth and dead, dying or diseased plant material; the removal of groups and individual plants which interfere with the growth of more desirable types of trees and the clearing away of lesser growth that may obscure outstanding trees, tree groups, or scenic views. Any part of tree trunks or base of plant material located on the Location Lines shall be considered within the limit of work.
- B. Densely wooded areas shall be trimmed to provide space for healthy growth by eliminating thinner, weaker trees and the reduction of number of varieties.
- C. The Contractor's attention is called to the requirements for work under this item. The desired appearance to be attained in certain areas of heavy growth may require three or more operations. First, the obvious dead, dying and diseased trees and undergrowth shall be cut and cleared out of the area. This work includes the removal of any previously fallen trees, branches, uprooted stumps and other debris as directed. Next, the area is to be thinned out, as directed, by removing the less desirable trees and brush which interfere with the growth of better plant material. Finally, clear out lesser growth which may obscure outstanding trees, tree groups or scenic views.
- D. Tree up-branching and shaping under this item will be restricted to trees which have limbs and branches restricting sight distance, extending over roadways, shoulders, turn outs, etc. Up-branching or trimming will be required to produce an 20-foot minimum vertical clearance over locations described hereinbefore, and the removal.

#### CLEARING AND GRUBBING

02222-2

of limbs and branches involved in this operation shall be accomplished as outlined hereafter.

- E. Quality of work must conform with accepted tree trimming practices.
- F. All trimming and pruning shall conform to recognized tree surgery practices, and particular note should be made that painting with an approved tree dressing or paint will be required on all cuts 2-inches or over in diameter.
- G. The dressing or paint shall be applied no later than two days after the cuts are made.
- H. Recognized tree surgery practices include among many others, the fact that all limbs and branches which require removal and all shrubs regardless of age must be cut flush either to a union with the next larger sound limb or branch or flush to the trunk of the tree.
- I. The cutting shall be performed by experienced woodsmen. Trained tree climbers are required for pruning of tall growth. Care shall be exercised by the Contractor to prevent injury to trees and shrubs designed to be preserved. Any injury to limbs, bark or roots of such plants shall be repaired by the Contractor, as directed, or the plants replaced without additional compensation for such repair or replacement.
- J. Standing trees, undesirable brush and existing stumps to be removed shall be cut flush with the ground and a 2 inch tolerance permitted and the resulting stumps or stubble then brushed or sprayed with a chemical spray material.
- K. Applications shall be by brush or spray so as to give complete coverage and wetting to the point of runoff.
- L. This application shall be completed within two days after the cutting.
- M. As the specified chemical herbicide is harmful to desirable roadside growth, the Contractor shall apply the chemical in such a manner that damage will not occur either from direct spray or from drift of the chemical on any desirable growth.
- N. The Contractor shall use all necessary precautions to prevent injury to crops or damage to other desirable growth on private abutting property, as well as those within the Right-of-Way, and shall assume full responsibility of damage.
- O. The Contractor may dispose of cut material by processing into a wood chip mulch and spreading uniformly throughout the cleared and thinned areas as directed by the Engineer.

CLEARING AND GRUBBING  
02222-3

### 3.4 DISPOSAL OF TREES

- A. All trees to be cleared shall become the property of the Contractor, and the satisfactory disposal of the wood in such trees outside the right-of-way shall become his/her responsibility.
- B. The trees, including cuttings and slash, shall be disposed of after cutting as soon as practicable and in a manner as not to detract from the appearance of the roadside.
- C. If the existing ground in the area is disturbed by any of the work or equipment, the Contractor shall rough-grade and loam and seed if necessary the disturbed areas, if so directed, without additional compensation.

### 3.5 DISPOSAL OF STUMPS AND BRUSH

- A. After removal, all stumps including the major root system shall be disposed of by the Contractor at his/her own responsibility outside the layout where the material will not cause obstruction to streams and will not detract from the appearance of the roadside.

### 3.6 DISPOSAL OF DUTCH ELM DISEASED WOOD

- A. Dutch Elm diseased wood shall be disposed of in accordance with the provisions of General Law, Chapter 87, Section 5 and Chapter 132, Sections 8 and 11, as amended; and in accordance with any additional local regulations.
- B. Where the work includes the removal of elm trees or the limbs of elm trees, such trees or limbs thereof shall be disposed of immediately after cutting or removal and such a manner as to prevent the spread of Dutch Elm Disease. This shall be accomplished by covering them with earth to a depth of at least 6 inches in areas outside the right-of-way location where the Contractor has arranged for disposal.
- C. Where the work includes the removal and disposal of stumps of elm trees, such stumps shall be completely disposed of immediately after cutting in the manner specified above.

END OF SECTION 02222

## CLEARING AND GRUBBING 02222-4

## SECTION 02273

### GEOTEXTILE FABRIC

#### PART 1 -GENERAL

##### 1.1 SUMMARY

- A. This section includes the following:
1. Providing geotextile fabric in foundation preparation for separation of existing soil from screened gravel or crushed stone beneath structures.
  2. Placing the geotextile fabric beneath the crushed stone or rip rap at tank overflow or storm drain outlets.
  3. Providing geotextile fabric for silt fence as indicated or specified.

##### 1.2 RELATED DOCUMENTS

- A. Drawings and general provisions of the Contract, including General and Supplementary Conditions and Division 1 Specification Sections, apply to this section, and.
1. Section 02020 - Erosion and Sediment Control
  2. Section 02200 - Earthwork

##### 1.3 SUBMITTALS

- A. Shop Drawings: Submit the following in accordance with Section 01300-SUBMITTALS:
1. At least two weeks prior to shipment, submit manufacturer's certificate of compliance and physical property data sheet indicating that requirements for materials and manufacture are in conformance as specified.
  2. For informational purposes only, submit manufacturer's printed installation instructions.

##### 1.4 QUALITY ASSURANCE

- A. GENERAL
1. Producer of geotextile fabric to maintain competent laboratory at point manufacture to insure control in accordance with ASTM testing procedures. Laboratory to maintain records of quality control results.

### GEOTEXTILE FABRIC 02273-1

2. Do not expose geotextile fabric, except the geotextile fabric for silt fence, to ultraviolet radiation (sunlight) for more than 14 days total in period of time following manufacture until geotextile fabric is installed and covered with fill or backfill material.
3. Take all precautions to protect geotextile fabric from damage resulting from any cause. Either repair or replace geotextile fabric to Engineer's satisfaction at no additional cost to the Owner.

#### 1.5 DELIVERY, STORAGE AND HANDLING

- A. Provide in accordance with manufacturer's recommendations.
- B. Provide geotextile fabric in rolls wrapped with protective covering to protect geotextile fabric from mud, dirt, dust, and debris. Label each roll of geotextile fabric with number or symbol to identify production run.
- C. Protect geotextile fabric from sunlight during transportation and storage. Do not leave geotextile fabric exposed to sunlight for more than two weeks during installation operations.

### PART 2 -PRODUCTS

#### 2.1 MANUFACTURERS

- A. Provide the following nonwoven (4.5 ounce per square yard) geotextile fabric, Model# US 120NW as manufactured by US Fabrics or approved equal.
- B. Provide the following woven geotextile fabric for silt fence:
  1. Amoco 2122 as manufactured by Arnoco Fabrics and Fibers Co., Atlanta, GA.
  2. Mirafi 100X as manufactured by Mirafi, Pendergrass, GA.
  3. Geotex 91OSC as manufactured by Synthetic Industry, Chattanooga, TN.
  4. Or acceptable equivalent product.

#### 2.2 MATERIAL

- A. Geotextile fabric shall conform to test requirements for minimum average roll value (weakest principle direction) for strength properties of any individual roll tested from manufacturing lot or lots of particular shipment in excess of minimum average value (weakest principle direction) as specified hereafter:
- B. Physical Properties of Minimum Average Roll of the 4.5-ounce per square yard Nonwoven geotextile fabric shall be.

### GEOTEXTILE FABRIC 02273-2



	Property	ASTM Test Method	Units	Value
1.	Tensile Strength	D4632	lbs.	120
2.	Elongation at Break	D4632	%	50
3.	Trapezoidal Tear Strength	D4533	lbs.	50
4.	Puncture Strength	D4833	lbs.	70
5.	Permittivity	D4491	Sec-1	1.5
6.	Apparent Opening Size	D4751	Sieve#	70
7.	Mullen Burst Strength	D3786	Psi	230
8.	UV Resistance %Retained	D4355	%	70
9.	Flow Rate	D4491	Gal/min/sf	120

C. Physical Properties of Minimum Average Roll of the woven geotextile fabric for silt fence shall be:

	Property	ASTM Test Method	Units	Value
1.	Grab Strength	D4632	lbs.	100
2.	Permittivity	D4491	sec- 1	0.10
3.	Apparent Opening Size	D4751	Sieve#	20-30
4.	Ultraviolet Stability	D4355	%	70

## PART 3- EXECUTION

### 3.1 INSTALLATION

- A. Install geotextile fabric in accordance with manufacturer's printed instructions.
- B. Place geotextile fabric on the foundation subgrade prior to placing the screened gravel or crushed stone. Use low ground pressure equipment to spread soil over the filter fabric to protect against tearing.
- C. Overlap geotextile fabric 18 inches minimum for unsewn lap joint.
- D. Do not permit traffic or construction equipment to travel directly on geotextile fabric.
- E. Place geotextile fabric in relatively smooth condition to prevent tearing or puncturing. Lay geotextile fabric loosely but without wrinkles or creases so that placement of the backfill materials will not stretch or tear geotextile fabric. Leave sufficient slack in geotextile fabric around irregularities to allow for readjustments.
- F. Patch all tears in geotextile fabric by placing additional section of geotextile fabric over tear with a minimum of 3 feet overlay.

## GEOTEXTILE FABRIC 02273-3

- G. Extend the geotextile fabric and wrap around the screened gravel or crushed stone along the perimeter of foundations and slabs.

3.2 CONTRACT CLOSEOUT

- A. Provide in accordance with Section 01700.

END OF SECTION 02273

GEOTEXTILE FABRIC  
02273-4

## SECTION 02515

### CONCRETE SIDEWALKS, WALKWAYS AND DRIVEWAY APRONS

#### PART 1-GENERAL

##### 1.1 SUMMARY

- A. Furnish all labor, materials, equipment and incidentals required and install concrete sidewalks, walkways and sidewalk aprons as specified herein.
- B. Damaged concrete sidewalks, walkways and driveway aprons as a result of construction shall be replaced to the nearest existing undisturbed concrete panel on all sides of construction disturbance.

##### 1.2 RELATEDWORK

- A. Earthwork is included in Section 02200.
- B. Loaming and hydroseeding is included in Section 02920. Cast-in-Place Concrete is included in Section 03300.

##### 1.3 REFERENCE STANDARDS

- A. Except as otherwise specified herein, the current Standard Specifications for Highways and Bridges, including all addenda, issued by the Commonwealth of Massachusetts, MassHighway (SSHB) shall apply to materials and workmanship required for the work of this Section.
- B. Where reference is made to one of the above standards, the revision in effect at the time of bid opening shall apply.

#### PART 2 -PRODUCTS

##### 2.1 MATERIALS

- A. Concrete shall be as specified in Section 03300, but in no case less than 3,500 psi at 28 days.
- B. Expansion joint shall be bituminous type, 1/2-in thick meeting AASHTO Spec. M-213-65.
- C. Materials for gravel base course shall be as specified in Section 02200.

### CONCRETE SIDEWALKS, WALKWAYS AND DRIVEWAYS

02515-1

## PART 3-EXECUTION

### 3.1 SIDEWALK, WALKWAY AND DRIVEWAY APRON INSTALLATION

- A. The full sidewalk, walkway or driveway apron panel(s) disturbed during construction shall be replaced. The Contractor shall saw cut the edges of the existing concrete at the edge of the existing undisturbed panels. The existing panels shall be saw cut at an existing tooled joint or removed to an existing expansion joint.
- B. The subgrade for sidewalks, driveways and driveway aprons shall be shaped parallel to the proposed surface of the sidewalks, walkways and driveway aprons and thoroughly compacted. All depressions occurring shall be filled and again compacted until the surface is smooth and hard.
- C. After the subgrade has been prepared, a gravel base course shall be placed. After being thoroughly compacted, the base course shall be at least 4-in in thickness and parallel to the proposed surface of the sidewalk, walkway or driveway apron. Reuse existing gravel base in areas not disturbed for trenching and provide new gravel base in areas disturbed for trenching.
- D. Forms:
  - 1. Side and transverse forms shall be smooth, free from warp, of sufficient strength to resist springing out of shape, of a depth to conform to the thickness of the sidewalk, walkway or driveway apron.
  - 2. All mortar or dirt shall be completely removed from forms that have been previously used. The forms shall be well staked and thoroughly braced and set to the established lines with their upper edge conforming to the grade of the finished sidewalk, walkway or driveway apron. Walkways shall have sufficient pitch to provide for surface drainage, but not to exceed 1/4-in per foot. Driveway aprons shall have sufficient pitch to provide for surface drainage and shall be finished to meet existing grades of the driveway and street.
- E. Placing and Finishing Concrete:
  - 1. Concrete sidewalks, walkways and driveway aprons shall be placed in slabs to dimensions to meet existing walkways and driveway aprons, except as otherwise ordered. The joints between new and existing concrete shall be separated by transverse, preformed expansion joint filler.
  - 2. Preformed expansion joint filler shall be placed adjacent to structures.
  - 3. Concrete shall be placed in such quantity that, after being thoroughly consolidated in place, it shall be 4-in in depth for sidewalks and walkways and 6-in in depth for driveway aprons. Finishing operations shall be delayed until all bleed water and water sheen has left the surface and concrete has started to stiffen. After water sheen has disappeared, edging operations shall be completed. After edging and jointing operations, the surface shall be

#### CONCRETE SIDEWALKS, WALKWAYS AND DRIVEWAYS

02515-2

floated with an aluminum or magnesium float. Immediately following floating, the surface shall be steel troweled. If necessary, tooled joints and edges shall be rerun before and after troweling to maintain uniformity. Finish with broom at right angles to alignment of walk, then round all edges with ¼-in radius after brooming.

4. When completed, the sidewalks, walkways and driveway aprons shall be kept moist and protected from traffic and weather for at least 3 days.

END OF SECTION 02515

CONCRETE SIDEWALKS, WALKWAYS AND DRIVEWAYS

02515-3

Sump Pump Amnesty Program  
Contract 2- Areas 5B, 5D and 15  
Waltham, Massachusetts

## SECTION 02576

### PAVEMENT REPAIR AND RESURFACING

#### PART 1 GENERAL

##### 1.1 SCOPE OF WORK

- A. Furnish all labor, materials, equipment and incidentals removed or disturbed by the Contractor's operations and as specified and required for this project.
- B. New pavement shall consist of initial temporary layer required to remain for a specified settlement time followed by the installation of final pavement layer.
- C. Streets, driveways, parking areas or sidewalk pavements damaged or disturbed by the Contractor's operations shall be repaired, replaced or restored in accordance with the requirements specified herein and as directed for the respective type of pavement replacement and in a manner satisfactory to the Owner.

##### 1.2 RELATED WORK

- A. Trimming edges of existing pavement for the purpose of excavating trenches shall be by either saw or wheel cutters.
- B. Roadway line painting shall be restored to match the conditions prior to construction.

##### 1.3 REFERENCE STANDARDS

- A. Except as otherwise specified herein; the current Standard Specifications for Highways and Bridges, including all addenda, issued by the Commonwealth of Massachusetts, Department of Public Works, shall apply to materials and workmanship required for the work of this Section.
- B. American Association of State Highways and Transportation Officials (AASHTO) AASHTO M144 - Standard Specification for Calcium Chloride.
- C. Where reference is made to one of the above standards, the revision in effect at the time of bid opening shall apply.

##### 1.4 SUBMITTALS

- A. Shop Drawings: Submit the following in accordance with Section 01300 – SUBMITTAL PROCEDURES.
  - 1. Product Data: Submit complete data on materials to be used in construction, including gradation tests for granular base.
  - 2. Design Data: Submit design mix for bituminous base, binder and top course.

### PAVEMENT REPAIR AND RESURFACING

02576-1

3. Material Certificates: Provide copies of materials certificates signed by material producer and Contractor, certifying that each material item complies with, or exceeds, specified requirements.

## 1.5 QUALITY ASSURANCE

- A. Provide in accordance with Section 01400 and as specified.
- B. Laboratory Testing Required:
  1. The bituminous mixture shall be compacted to at least 95% of the density achieved on the laboratory testing of the design mix for the project. The density of the Bituminous Concrete Pavement will be determined by using either the following tests; Nuclear Density Gauge Method ASTM D2950 or the Bulk Specific Gravity Method AASHTO-T166.
- C. Thickness: Test in-place asphalt concrete courses for compliance with requirements for thickness. Repair or remove and replace unacceptable paving as directed by Engineer. In-place compacted thickness will not be accepted if exceeding the following allowable variation from required thickness:
  1. Binder Course 1-inch, plus no minus
  2. Top (Wearing) Course: 1/2-inch, plus no minus

## 1.6 PROJECT SITE CONDITIONS

- A. Environmental Requirements:
  1. Do not place materials when underlying surface is muddy, frozen, or has frost, snow, or water thereon.
  2. Do not place concrete when air temperature at time of placement, or anticipated temperature for following 24 hours, is lower than 40°F or higher than 90°F.
  3. Apply prime and tack coats when ambient temperature is above 50°F and when temperature has not been below for 12 hours immediately prior to application.
  4. Binder Course may be placed when air temperature is above 30°F and rising.
  5. Grade Control: Establish and maintain required lines and elevations.
- B. Existing Conditions:
  1. Drawings show approximate locations of paving areas.
  2. Drawings show approximate location of existing structures along pipeline route.
  3. Location of subsurface borings and the logs are indicated on drawings.

### PAVEMENT REPAIR AND RESURFACING

02576-2

## 1.7 GUARANTEE

- A. All final pavement placed in City streets shall be warranted by the Contractor for a period of one year. During this period all areas which have settled or are unsatisfactory for traffic shall be removed and replaced at no cost to the City, including the cost of Traffic Police.

## PART 2 PRODUCTS

### 2.1 MATERIALS

- A. Calcium chloride shall conform to AASHTO M144, Type I or Type II.
- B. Initial pavement (temporary paving) shall be Binder Course, conforming to the referenced specification, Section M3.11, Class I, Type I-1 bituminous concrete.
- C. For locations not receiving a full width overlay, final trench pavement shall consist of Binder Course and Top Course, conforming to the referenced specification, Section M3.11, Class I, bituminous concrete.

## PART 3 -EXECUTION

### 3.1 GENERAL

- A. Paving shall consist of an initial layer of temporary paving followed by a second layer of permanent paving.
- B. Within 4 days of backfilling in areas to be paved, the Contractor shall commence temporary paving, unless directed otherwise in writing by the Engineer. The Contractor shall not leave excavated areas over weekends unless through written approval of the Engineer.

After completion of the backfilling, final pavement shall not be placed over trenches until the temporary paving has been in place for at least 90 days, or a winter settlement period, unless otherwise directed in writing by the Engineer. Where it is used as backfill, final pavement may be installed once the CDF has cured.

- D. Materials for pavement shall be mixed, delivered, placed and compacted in accordance with the referenced specification, Sections M3.11 and 460 and as specified herein.
- E. Whenever the subbase becomes dry enough to cause dust problems, spread calcium chloride uniformly over the gravel surface in sufficient quantity to eliminate the dust.
- F. No vehicular traffic or loads shall be permitted on the newly completed pavement until adequate stability has been attained and the material has cooled sufficiently to prevent distortion or loss of fines. If the climatic or other conditions warrant it, the period of time before opening to traffic may be extended at the discretion of the Engineer.

## PAVEMENT REPAIR AND RESURFACING

02576-3



- G. Pavement Construction Period. No pavement shall be constructed during the period from December 20 to March 15, without approval in writing from the engineer.

### 3.2 PREPARATION

#### A. Protection of existing Roadways:

- 1. Saw cut existing pavement to required width and depth to avoid damage to adjacent pavement, curbs, gutters, or other structures and as indicated on the drawings.

#### B. Sub-Surface Preparation:

##### 1. Pavement Subbase:

- a. The subbase to be placed under pavement shall be a minimum of 12-inches thick after compaction. Subbase shall be evenly spread and thoroughly compacted in accordance with the Contract Documents.
- b. The subbase shall be spread in layers not more than 8 - inches thick except the last layer of gravel shall be 4-inches thick, compacted measure. All layers shall be compacted to not less than 95 percent of the maximum dry density of the material as determined by ASTM D1557 Method C at optimum moisture content.
- c. Complete subbase preparation, including dynamic compaction, for full width before placing surfacing materials.

##### 2. Subgrade:

- a. Prepare subgrade in accordance with Section 0221.
- b. Complete subgrade preparation, including dynamic compaction, for full width before placing surface materials. .
- c. Stabilize subgrades in accordance with Section 02221 so that loaded construction vehicles do not cause rutting or displacement when depositing materials.

### 3.3 DESCRIPTION

#### A. In general, the following pavement repairs shall be made:

- 1. Wherever existing paved areas are disturbed a 2-inch temporary pavement layer is to be placed. When, and if, this material is disturbed during additional excavation work required for utility installation it shall be replaced. After a 90-day minimum period, or a winter settlement period, a permanent pavement wearing course shall be installed.

## PAVEMENT REPAIR AND RESURFACING

02576-4

2. In roads and streets that are not scheduled to have full width overlay placed, following a 90-day minimum period, or a winter settlement period, the temporary layer shall be removed, the pavement edges cutback 12-inches from existing, and a permanent pavement wearing course installed.
3. In roads and streets that are to receive a full width overlay, following a 90-day minimum period, or a winter settlement period, the full width 1-1/2 inch overlay of permanent pavement wearing course shall be placed over the existing pavement and the 2-inch temporary pavement layer.
4. Driveways shall be paved as described in 3.3A2, above.
5. Driveway aprons and waterways shall be paved as part of the work
6. Asphalt berms shall be replaced as part of the work.
7. The paving thicknesses specified above may be increased based on permit or field requirements. Payment for additional thickness shall be made at the unit price bid in the proposal

### 3.4 INSTALLATION

#### A. Initial pavement:

1. An initial layer of temporary pavement shall be placed wherever existing pavement has been removed or disturbed as soon as practical after backfilling is completed.
2. The pavement subbase shall be excavated, graded, and compacted to a depth of 2-inches below the existing pavement.
3. Hose clean with water all road surfaces adjacent to the area to be paved. No paving is to be placed until subsurface is dry.
4. The initial pavement layer shall be a hot mixed binder course placed and compacted to a thickness of 2-inches by steel-wheeled rollers of sufficient weight to thoroughly compact the bituminous concrete without damaging the existing pavement. The new pavement shall be rolled smooth and even with the existing pavement.
5. Initial pavement shall be maintained in a condition suitable for traffic until replaced or overlaid by final pavement. Defects shall be repaired within 24 hours of notification of such defects.

#### B. Final pavement: areas not receiving full width overlay

1. Remove initial pavement and subbase to 3-1/2-in. below existing pavement. Saw cut all edges back 12-inches from edge of original trench, keeping the final

## PAVEMENT REPAIR AND RESURFACING

02576-5

pavement edge neat and straight. Shape and compact subbase to 95 percent of maximum dry density as determined by ASTM 01557, Method C.

2. Trim loose edges of existing pavement. Broom and tack coat all edges with emulsified or cutback asphalt.
3. Place Binder Course and compact to 2-in. thickness by steel-wheeled roller.
4. Place Top Course and compact to 1-1/2-in. thickness, finish smooth, dense and flush with surface of existing pavement.
5. Match roadway edges to and existing driveways or berms as required.

C. Final pavement: areas receiving full width overlay

1. The permanent pavement wearing course shall be a hot mixed top course and placed to a compacted thickness of 1-1/4 inches: Leveling course material shall be placed in vertical depression in the existing pavement which are greater than 0.5 inches from the surrounding existing pavement level.
2. Prior to the application of the overlay course, the entire surface shall be cleared of dirt and debris using power sweepers, and then tack coated with cut-back asphalt emulsion.
3. All thicknesses are measured after rolling. The permanent surface course shall be evenly spread and rolled with a power roller having a minimum weight of 5-tons.
4. The overlay course shall be keyed to the existing pavement at ends of pavement repair sections, including driveways. Keys shall be cut to full pavement depth and be at minimum width of 8-inches.

D. Pavement Markings:

1. The Contractor shall replace all reflectorized pavement markings removed or covered-over in carrying out the work, and as directed by the Engineer, no sooner than 48 hours after completion of overlay pavement. Markings shall conform to the latest standards of the municipality or agency having jurisdiction over the roadway. The markings shall be thermoplastic markings, 4-inches wide, white or yellow, single or double lines as required for road markings, and 12-inches wide, white for crosswalk markings.
2. Markings shall conform to MHD: M7.01.03 - White Thermoplastic Reflectorized Pavement Markings and M7.01.04 - Yellow Thermoplastic Reflectorized Pavement Markings.
3. The Contractor shall provide temporary markings on the temporary pavements where existing markings are removed at no additional cost to the Owner.

PAVEMENT REPAIR AND RESURFACING

02576-6

E. Curb and Gutter Replacement:

1. Replace curb and gutter with same material to pre-construction lines and curb sections. Reset granite curb to pre-construction line and grade.
2. Removal and replacement of curbing shall be done in accordance with Sections 501 and 580, as applicable of the MHD Specifications for Highways and Bridges.
3. Provide expansion joints at each intersection with existing curb sections.
4. Use expansion joints one inch wide. Fill with expansion joint material and cut to shape of curb section.

F. Sidewalk, Driveway, and Parking Area Replacement:

1. Gravel sidewalks:
  - a. Gravel sidewalks shall be restored to a condition at least equal to that existing immediately before the work was started.
2. Bituminous concrete sidewalks, driveways, and parking areas:
  - a. Construct in accordance with MHD Section 701, sidewalks, Wheelchair Ramps and Driveways.
  - b. The subgrade shall be shaped parallel to the proposed surface of the sidewalk or driveway and shall be thoroughly rolled and tamped. All depressions occurring shall be filled with suitable material and again rolled or tamped until the surface is smooth and hard in order for a gravel foundation to be placed upon it.
  - c. The sidewalk, driveway, or parking area shall be a minimum of 2-1/2 compacted inches thick, laid in two equal courses.
  - d. Sidewalk cross slopes cannot exceed 2 percent as required by the Americans with Disabilities Act (ADA). The Contractor shall merge new sidewalk slopes into existing sidewalk slopes as required by ADA.
3. Cement concrete sidewalks, and driveways
  - a. Construct in accordance with MHD Section 701, Sidewalks, Wheelchair Ramps and Driveways.
  - b. Use 6x6, W10xW10 welded wire reinforcement.
  - c. Concrete sidewalks shall be 4-inches thick and concrete driveways shall be 6-inches thick.

PAVEMENT REPAIR AND RESURFACING  
02576-7

- d. The subgrade for the walk or driveway shall be shaped to a true surface conforming to the proposed slope of the walk, thoroughly rolled at optimum moisture content, and tamped with a power roller weighing not less than one ton and not more than 5 tons. All depressions occurring shall be filled with suitable material and again rolled or tamped until the surface is smooth and hard.
  - e. After the subgrade has been prepared, a subbase of gravel at optimum moisture content shall be placed, thoroughly rolled by a power roller, and tamped. The gravel shall be a minimum of 8 inches in thickness.
  - f. The forms shall be smooth, free from warp, strong enough to resist springing out of shape, and deep enough to conform to the thickness of the proposed walk or driveway. All mortar or dirt shall be completely removed from forms that have been previously used. The forms shall be well staked thoroughly braced, and set to the established lines with their upper edge conforming to the grade of the finished walk or driveway.
  - g. The finished surface shall have sufficient pitch from the outside edge to provide for surface drainage. This pitch shall be  $\frac{1}{4}$  of an inch per foot unless otherwise directed by the Engineer. Before the concrete is placed, the subbase for sidewalks shall be thoroughly dampened until it is moist throughout but without puddles of water.
4. Handicap ramps:
- a. Handicap ramps will be installed where indicated on the drawings, in accordance with these contract documents.
  - b. Construct in accordance with MHD Section 701, Sidewalks, Wheelchair Ramps and Driveways.
  - c. The Contractor shall install curb cuts and accessible walkways in accordance with the requirements of the Americans with Disabilities Act and as required in 521 CMR (2/23/96 edition) Sections 21 and 22.
  - d. Handicap ramps are to be constructed of cement concrete unless otherwise approved by the Engineer.
  - e. Existing granite curbing shall be removed, cut if required and reset to allow for the ramp construction. New curbing shall be installed to replace granite curbing damaged by the Contractor.
5. General:
- a. Valve boxes, manhole frames, and all other castings shall be carefully set to the proposed finished grades.

PAVEMENT REPAIR AND RESURFACING  
02576-8

G. Berms and Waterways

1. Bituminous curbing shall be replaced as required. Curbing shall be machine laid and conform to grade of roadway and adjacent curb areas.
2. Bituminous berms shall be replaced as required. Berms shall be machine laid and conform to the grade of the roadways. Berms shall be placed in accordance with MHD Specification 470.20.
3. Bituminous waterways which have been disturbed by construction operations shall be repaired or replaced. The waterways shall be repaired and constructed in accordance with the applicable requirements of Section 280 of the MHD Specifications. Waterways shall be placed in two 1-1/2-inch thick courses on a prepared gravel base. Material shall be compacted by tamping or rolling.

3.5 RAISING BOXES AND CASTINGS

- A. Prior to placing permanent pavement, the Contractor shall raise all boxes, utility castings, as required, to proper grade.
- B. Contractor shall coordinate with all utility companies to obtain their requirements on Castings.
- C. Castings which need to be raised or adjusted to complete final top course full-width paving shall be done immediately prior to paving.

END OF SECTION 02576

PAVEMENT REPAIR AND RESURFACING  
02576-9

## SECTION 02609

### REINFORCED CONCRETE DRAIN PIPE

#### PART 1 -GENERAL

##### 1.1 RELATED DOCUMENTS

- A. Drawings and general provisions of the Contract, including General and Supplementary Conditions and Division 1 Specification Sections, apply to this section.

##### 1.2 SUMMARY

- A. This section includes the following:
  - 1. Providing and testing reinforced concrete pipe as indicated and specified.
- B. Related sections include the following:
  - 1. Section 02210 - Earth Excavation, Backfill, Fill and Grading
  - 2. Section 02211 -Rock Excavation and Disposal
  - 3. Section 02223 - Screened Gravel
  - 4. Section 02430- Manholes
  - 5. Section 02431 - Catchbasins
  - 6. Section 03300- Cast-in-Place Concrete

##### 1.3 SUBMITTALS

- A. Shop Drawings: Submit the following in accordance with Section 01300 - SUBMITTAL PROCEDURES:
  - 1. Shop drawings showing pipe dimensions, reinforcement, joint and other details for each type and class pipe.
  - 2. If less than 100 units of given size and class, submit three certified copies of pipe tests on identical pipe units made by the same manufacturer within past year.
  - 3. If more than 100 units of given size and class, submit:

### REINFORCED-CONCRETE DRAIN PIPE 02609-1

- a. Reinforcing steel mill or sample test reports for each shipment of steel.
- b. Cement mill test reports for each shipment of cement.
- c. Aggregate test reports before manufacturer of pipe and monthly thereafter during production.
- d. Records of average daily temperature and number of days pipe units cured, when average daily temperature below 60 deg.F.
- e. Concrete cylinder compression test results within three days after test.
- f. Absorption test results.
- g. Pipe load-bearing test results.

#### 1.4 QUALITY ASSURANCE

- A. Provide in accordance with Section 01400 and as specified.
- B. Provide pipe made by manufacturer of established good reputation in the industry and manufactured in a plant adapted to meet the design requirements of the pipe.
- C. Accept on basis of tests of materials, absorption tests, plant load-bearing tests, pressure tests, and inspection of completed product.
- D. Testing Agencies:
  - 1. Engage an acceptable independent testing laboratory to perform or witness tests, other than mill tests on reinforcing steel and cement, and certify the results.
- E. Allow Owner to engage independent testing laboratory at Owner's expense to perform additional inspection or tests of any or all pipe units at manufacturer's plant or elsewhere. Accept such additional inspections or tests as test results of record.
- F. Conduct all tests in accordance with applicable ASTM Specifications.
  - 1. Materials

### REINFORCED-CONCRETE DRAIN PIPE 02609-2



- a. Reinforcing Steel: Mill test reports or reports on samples taken from each shipment to pipe manufacturer.
  - b. Cement: Mill test reports for each shipment to pipe manufacturer. Cement for this project kept segregated from other cement.
  - c. Aggregates: Tests to demonstrate compliance with specified requirements. Initial tests prior to commencement of pipe manufacturer and additional tests at least monthly during production of pipe.
2. Concrete: Compression tests on standard cylinders for first pipe unit, then for every 100 cu. yd. of concrete used in pipe fabrication, or for each additional 200 units of pipe, whichever is lesser amount of concrete. Make 4 cylinders for each test and break them at 7, 14 and 28 days. Set aside one cylinder in case of unsatisfactory break.
  3. Conduct pipe tests on units selected at random by Engineer.
    - a. Absorption: Before load test, take 3 cores from each unit. Test by boiling. Average absorption: Maximum 8 percent of dry weight, no single test more than 9 percent.
    - b. Load-Bearing: Before delivery, conduct one test on one pipe unit of each size and class, and one additional test for each 200 units of each size and class, after taking cores for absorption test. Carry test to specified load to produce 0.01- in. crack; if no crack produced, pipe may be used. Plug cored holes with mortar as specified for repairs.
    - c. Pressure: Before delivery, test six units of each size and class. Join units in normal manner using joint to be furnished and bulkhead end units independently. Average internal hydrostatic pressure of 10 psi for 10 minutes minimum without visible leakage from joints or barrels. Perform test in presence of Engineer.

G. Inspection by Engineer:

1. At place of manufacture.
2. At site of work after delivery.
3. Reject pipe at any time if it fails to meet specified requirements, even if sample pipe accepted at plant.
4. Immediately remove rejected pipe from site.

## 1.5 DELIVERY, STORAGE AND HANDLING

- A. Provide in accordance with Section 01610.

### REINFORCED-CONCRETE DRAIN PIPE 02609-3

## PART 2- PRODUCTS

### 2.1 PIPE FABRICATION

- A. Interior: Smooth; no projections, indentations, offsets or irregularities.
- B. Classes: As indicated.
- C. Conform to ASTM C76, modified as follows:
  - 1. Provide with proper concrete ends true to size; form on machined rings to ensure accurate joint.
  - 2. Use Type II cement, no admixtures unless permitted by Engineer.
  - 3. Cement content in concrete: At least 564 lbs. per cu. yd.
  - 4. Aggregates: Fine and Coarse Aggregate per Sections 03300, 03346.
  - 5. Reinforcement: Section 03200. Longitudinal reinforcement continuous. Minimum cover 3/4 in. allowed. Elliptical reinforcement not allowed.
  - 6. Minimum laying length: 8-ft. except where otherwise indicated or permitted.
  - 7. Curing: Saturated steam at temperature between 100 and 130 deg. F. for minimum 12 hours.
  - 8. Shipping: Aged at least 450 day-degrees including steam curing period before shipping. Day-degrees defined as total number of days times the average daily air temperature at pipe surface. (Example: Five days at daily average temperature of 60 deg. F. equals 300 day- degrees.)
  - 9. No lift holes.
  - 10. Repairs
    - a. Mortar: Minimum compressive strength 4,000 psi at 7 days, and 5,000 psi at 28 days, when tested in 3-in by 6-in. cylinders stored in standard manner.
    - b. Only those allowed by ASTM C76.
  - 11. Mark permanently on inside and outside of pipe:
    - a. Date of manufacture
    - b. Class

#### REINFORCED-CONCRETE DRAIN PIPE

02609-4

- c. Size
- d. Consecutive number
- e. Manufacturer's trade mark

## 2.2 FITTINGS AND SPECIALS

- A. Reinforcement: As required for class of pipe to be used.
- B. Details: As indicated and conforming to approved shop drawings.
- C. Pipebells for chimneys or building connections:
  - 1. Formed or built into pipe unit at plant.
  - 2. Vitrified-clay bells with premolded gaskets: ASTM C700, extra strength, and ASTM C425.

## 2.3 JOINTS

- A. Rubber Gasket Type: Gaskets in compression permitting longitudinal and angular movement.
- B. Pipe 36 in. or less in diameter: 0-ring: ASTM C361 and as specified.
- C. Pipe larger than 36 in. in diameter: 0-ring or ribbed-gasket: ASTM C443 and as specified.
- D. Design:
  - 1. No visible leakage, when tested average internal hydrostatic pressure of 10 psi..
  - 2. Diameter of joint surfaces compressing the gasket: Not off more than 1/16 in. from true diameter, or as permitted by above ASTM Standard, whichever is less.
- E. Composition and Texture of Gaskets:
  - 1. Resistant to common ingredients of sewage, industrial wastes, and groundwater. Permanent under anticipated service conditions.
  - 2. Fabricated by manufacturer regularly making rubber gaskets for pipe.

## PART 3- EXECUTION

### 3.1 HANDLING

- A. Handle into position in acceptable manner.

## REINFORCED-CONCRETE DRAIN PIPE 02609-5

- B. Furnish suitable devices for support when lifted.

### 3.2 INSTALLATION

- A. Inspect before installation. Remove and replace defective units. Clear of debris and dirt.

- B. Bedding:

1. Support on compacted screened gravel per Section 02223, or as indicated. Do not permanently support on saddles, blocking, or stones.
2. Provide bell holes for imparting bearing pressure to pipe barrel.

- C. Alignment:

1. Install to line and grade indicated.
2. Maintain close joints with next adjoining unit. Match inverts. Do not drive down to grade by striking.

- D. Jointing:

1. Clean and lubricate bell or groove before jointing per manufacturer's recommendation. Push into place. Force pipe units together by proper devices leaving minimum open recess inside and outside and achieving tightly sealed joints. Avoid force that could wedge apart or split bell or groove ends. Do not pull or cramp joints, except where permitted by Engineer.
2. Inspect proper position of joint gasket with feeler gage furnished by Contractor.
3. Remove and replace unfittable pipe units with suitable units and new gaskets.
4. Install gaskets and assemble joints in accordance with recommendations of manufacturers of joint material and pipe, subject to acceptance by Engineer. Provide watertight pipeline with flexible joints.

- E. Backfill:

1. Compact gravel between pipe and sides of trenches to hold pipe in correct alignment. Fill bell holes with screened gravel and compact as indicated.
2. Prevent floatation in trench.

- F. Cleaning:

1. Use watertight plugs in open ends of pipe and branches when installation not in progress.

### REINFORCED-CONCRETE DRAIN PIPE

02609-6

2. Do not use pipeline as conductor for trench drainage.
3. Prevent earth, water, and other material from entering pipeline.
4. Clean pipeline and manholes upon completion. Prevent soil, water, and debris from entering existing sewers.

### 3.3 CONTRACT CLOSEOUT

- A. Provide in accordance with Section 01700.

END OF SECTION 02609

## SECTION 02622

### POLYVINYL CHLORIDE GRAVITY PIPE

#### PART 1 -GENERAL

#### PART 1- GENERAL

##### 1.1 RELATED DOCUMENTS

- A. Drawings and general provisions of the Contract, including General and Supplementary Conditions and Division 1 Specification Sections, apply to this Section.

##### 1.2 SUMMARY

- A. This section includes the following:
  - 1. Providing and testing of pipe, pipe fittings and specials, jointing materials, and accessories, of various sizes, classes, joints and types, and appurtenant work, at the locations and to the lines and grades as indicated and/or as directed, complete in place, in accordance with the drawings and specifications.
  - 2. The pipe specified under this section shall include all gravity flow sanitary sewers.
- B. Related sections include the following:
  - 1. Section 02210 - Earth Excavation, Backfill, Fill and Grading
  - 2. Section 02601- Manholes

##### 1.3 SUBMITTALS

- A. Shop Drawings: Submit the following in accordance with Section 01300- SUBMITTAL PROCEDURES:
  - 1. Submit shop drawings or descriptive literature, or both showing pipe dimensions, joints, joint gaskets, and other details for each size of pipe to be furnished for the project. All pipe furnished shall be manufactured only in accordance with the specifications and the drawings.

##### 1.4 QUALITY ASSURANCE

- A. Provide in accordance with Section 01400 and as specified.

##### 1.5 DELIVERY, STORAGE AND HANDLING

- A. Provide in accordance with Section 01610. PART 2 - PRODUCTS

### POLYVINYL CHLORIDE GRAVITY PIPE

02622-1

## 2.1 PIPE FITTINGS AND SPECIALS

- A. The polyvinyl chloride pipe and fittings, including those required for stubs, shall conform to ASTM Standard Specifications for Type PSM PVC Sewer Pipe and Fittings, Designation ASTM D3034, latest revision, for sizes 4"-15" and ASTM F679, latest revision, for sizes 18"-27". The pipe shall have a maximum pipe diameter to wall thickness ratio (SDR) of 35. The pipe shall be tested by the flat plate deflection method at a minimum of 45 psi at 5 percent deflection in accordance with ASTM D 2412. Standard laying lengths shall be either 13 feet or 20 feet.
- B. Specials, if required, shall conform to the Specifications for straight pipe insofar as applicable and to the details indicated on the Drawings or bound into the back of the Specifications.
- C. Insulation shall be manufactured by Thermal Pipe Systems, Braintree, Massachusetts, Atlas Insulation, Ayer, Massachusetts or Insulated Piping Systems Inc., Canton, Massachusetts, or equal. Insulation shall be factory formed-in-place polyurethane foam insulation having nominal thickness of 3", with an in-place density of 2.5 pcf, and a "K" factor of 0.14 BTU/in./hr/deg./F/sq.ft. Straight joints between insulated pipe lengths, and the end section of non-insulated pipe shall be 20-gauge corrugated aluminum performed to be fastened with stainless steel screws and bands. Jackets shall have expansion joints at 25-foot intervals. Sections of jacket shall have 2-inch minimum at all seams.

## 2.2 JOINTS

- A. Joints for the polyvinyl chloride pipe shall be push-on bell and spigot joints using elastomeric ring gaskets. The gaskets shall be securely fixed into place in the bells so that they cannot be dislodged during joint assembly. The gaskets shall be of a composition and texture which is resistant to common ingredients of sewage and industrial wastes, as well as petroleum products (oil, gasoline, etc.) and groundwater, and which will endure permanently under the conditions of the proposed use. The joints shall conform to ASTM Standard Specifications for Joints for Drain and Sewer Plastic pipes using Flexible Elastomeric Seals, Designation D3212.

## 2.3 INSPECTION, TESTS AND ACCEPTANCE

- A. All pipe delivered to the job site shall be accompanied by test reports certifying that the pipe and fittings conform to the above-mentioned ASTM Specifications. In addition, the pipe shall be subject to thorough inspection and tests, the right being reserved for the Engineer to apply such tests as he deems necessary.
- B. All tests shall be made in accordance with the methods prescribed by the above mentioned ASTM Specifications, and the acceptance or rejection shall be based on the test results.
- C. The Contractor shall furnish all labor to assist the Engineer in inspecting the pipe. Pipe will be inspected upon delivery, and such as does not conform to the requirements of this

### POLYVINYL CHLORIDE GRAVITY PIPE

02622-2

contract shall be rejected and shall immediately be removed from the project site by the Contractor.

## PART 3-EXECUTION

### 3.1 HANDLING PIPE

- A. All pipe shall be stored at the site until installation in a manner which will keep the pipe at ambient outdoor temperatures. Temporary shading shall be provided as required to meet this requirement. Simply covering the pipe which allows temperature build-up when exposed to direct sunlight will not be permitted.
- B. Care shall be taken to avoid damaging the pipe and fittings.

### 3.2 INSTALLATION

- A; Each pipe unit shall be inspected before being installed. No single piece of pipe shall be laid unless it is generally straight. The centerline of the pipe shall not deviate from a straight line drawn between the centers of the openings at the ends of the pipe by more than 1/16-inch per foot of length. If a piece of pipe fails to meet this requirement for straightness, it shall be rejected and removed from the site. Any pipe unit or fitting discovered to be defective either before or after installation shall be removed and replaced with a sound unit.
- B. No pipe or fitting shall be permanently supported on saddles, blocking, or stones. Crushed stone shall be as specified in Section 02435.
- C. Suitable bell holes shall be provided, so that after placement, only the barrel of the pipe receives bearing pressure from the supporting material. Special care shall be taken to hold the trench width at the crown of the pipe to the maximum indicated on the Trench Detail included in the Details section of these specifications.
- D. All pipe fittings shall be cleared of all debris, dirt, etc., before being installed and shall be kept clean until accepted in the completed work.
- E. Pipe and fittings shall be installed to the lines and grades indicated on the Drawings. Care shall be taken to ensure true alignments and gradients.
- F. Before any joint is made, the previously installed unit shall be checked to assure that a close joint with the adjoining unit has been maintained that the inverts are matched and conform to the required grade. The pipe shall not be driven down to the required grade by striking it with a shovel handle, timber or other unyielding object.
- G. All joint surfaces shall be cleaned. Immediately before jointing the pipe, the bell or groove shall be lubricated in accordance with the manufacturer 's recommendation. Each pipe unit shall then be carefully pushed into place without damage to pipe or gasket. Suitable devices shall be used to force the pipe units together so that they will fit with minimum open recess inside and outside and have tightly sealed joints. Care shall be taken not to use such force as to wedge apart and split the bell or groove ends.

## POLYVINYL CHLORIDE GRAVITY PIPE

02622-3



- H. Joints shall not be "pulled" or "cramped" unless permitted by the Engineer.
- I. Where any two pipe units do not fit each other closely enough to enable them to be properly jointed, they shall be removed and replaced with suitable units and new gaskets.
- J. Details of gasket installation and joint assembly shall follow the directions of the manufacturers of the joint materials and of the pipe, all subject to review by the Engineer. The resulting joints shall be watertight and flexible.
- K. All premolded gasket joint polyvinyl chloride pipe of a particular manufacturer may be rejected if there are more than five unsatisfactory joint assembly operations or "bell breaks" in 100 consecutive joints, even though the pipe and joint conform to the appropriate ASTM Specifications as hereinbefore specified. If the pipe is unsatisfactory, as determined above, the Contractor shall, if required, remove all pipe of that manufacturer of the same shipment from the work and shall furnish pipe from another manufacturer which will conform to all of the requirements of these specifications.
- L. Open ends of pipe and branches shall be closed with polyvinyl chloride stoppers secured in place in an acceptable manner.
- M. After each pipe has been properly bedded, enough crushed stone shall be placed between the pipe and the sides of the trench, and thoroughly compacted, to hold the pipe in correct alignment. Bell holes, provided for jointing, shall be filled with crushed stone and compacted, and then crushed stone shall be placed compacted to complete the pipe bedding.
- N. The Contractor shall take all precautions to prevent flotation of the pipe in the trench.
- O. At all times pipe installation is not in progress, the open ends of the pipe shall be closed with temporary watertight plugs, or by other acceptable means.
- P. If water is in the trench when work is to be resumed, the plug shall not be removed until suitable provisions have been made to prevent water, earth, or other substances from entering the pipe.
- Q. Pipelines shall not be used as conductors for trench drainage during construction.

### 3.3 ALLOWABLE PIPE DEFLECTION

- A. Pipe provided under this Specification shall be so installed as to not exceed a maximum deflection of 5.0 percent. Such deflection shall be computed by multiplying the amount of deflection (nominal diameter less minimum diameter when measured) by 100 and dividing by the nominal diameter of the pipe.
- B. Upon completion of a section of pipe, including placement and compaction of backfill, the Contractor shall measure the amount of deflection by pulling a specially designed gage assembly through the completed section. The gage assembly shall be in accordance

#### POLYVINYL CHLORIDE GRAVITY PIPE

with the recommendations of the pipe manufacturer, and be reviewed by the Engineer. The section of pipe must be placed and backfilled for a minimum of 90 days before the deflection can be measured.

- C. Should the installed pipe fail to meet this requirement, the Contractor shall do all work to correct the problem without additional compensation.

### 3.4 CLEANING

- A. Care shall be taken to prevent earth, water and other materials from entering the pipeline. As soon as possible after the pipe and manholes are completed, the Contractor shall clean out the pipeline and manholes being careful to prevent soil, water and debris from entering any existing pipe.

### 3.5 TESTING OF PIPE

- A. If the visual inspection of the completed pipe or any part thereof shows any pipe, manhole or joint which allows infiltration of water in a noticeable stream or jet, the defective work or material shall be replaced or repaired as directed.
- B. After completing installation and backfill of pipe, the Contractor shall, at his expense, conduct a line acceptance test using low pressure air.
- C. Equipment used shall meet the following minimum requirements.
- D. Pneumatic plugs shall have a sealing length equal to or greater than the diameter of the pipe to be inspected.
- E. Pneumatic plugs shall resist internal test pressures without requiring external bracing or blocking.
- F. All air used shall pass through a single control panel.
- G. Three individual hoses shall be used for the following connections.
  - 1. From control panel to pneumatic plugs for inflation.
  - 2. From control panel to sealed line for introducing the low pressure air.
  - 3. From sealed line to control panel for continually monitoring the air pressure rise in the sealed line.
- H. All pneumatic plugs shall be seal tested before being used in the actual test installation. One length of pipe shall be laid on the ground and sealed at both ends with the pneumatic plugs to be checked. Air shall be introduced into the plugs to 25 psig. The sealed pipe shall be pressurized to 5 psig. The plugs shall hold against this pressure without bracing and without movement of the plugs out of the pipe.

## POLYVINYL CHLORIDE GRAVITY PIPE

02622-5

- I. After a manhole to manhole reach of pipe has been backfilled and cleaned, and the pneumatic plugs are checked by the above procedure, the plugs shall be placed in the line at each manhole and inflated to 25 psig. Low pressure air shall be introduced into this sealed line until the internal air pressure reaches 4 psig greater than the average back pressure of any groundwater that may be over the pipe. At least two minutes shall be allowed for the air pressure to stabilize.
- J. After the stabilization period (3.5 psig minimum pressure in the pipe), the air hose from the control panel to the air supply shall be disconnected. The portion of line being tested shall be termed "Acceptable" if the time required in minutes for the pressure to decrease from 3.5 to 2.5 psig (greater than the average back pressure of any groundwater that may be over the pipe) is not less than the time shown for the given diameter in the following table.

Pipe Diameter	Specification Time for Length Shown (min:sec)			
<u>Inches</u>	<u>100ft.</u>	<u>200ft.</u>	<u>300ft.</u>	<u>400ft.</u>
6	5:40	5:40	5:40	5:42
8	7:34	7:34	7:36	10:08
10	9:26	9:26	11:52	15:49
12	11:20	11:24	17:05	22:47
15	14:10	17:48	26:42	35:36
18	17:00	25:38	38:27	51:16
21	19:50	34:54	52:21	69:48
24	22:47	45:34	68:22	91:10

- K. In areas where groundwater is known to exist, the Contractor shall install a 1/2-inch diameter capped pipe nipple, approximately 10-inches long, through the manhole wall adjacent to one of the sewer lines entering the manhole. This shall be done at the time the line is installed. Immediately prior to the performance of the Line Acceptance Test, the groundwater shall be determined by removing the pipe cap, blowing air through the pipe nipple into the ground so as to clear it, and then connecting a clear plastic tube to the nipple. The hose shall be held vertically and a measurement of the height in feet of water over the invert of the pipe shall be taken after the water has stopped rising in this plastic tube. The height in feet shall be divided by 2.3 to establish the pounds of pressure that will be added to all readings. (For example, if the height of water is 11-112 feet, then the added pressure will be 5 psig. This increases the 3.5 psig to 8.5 psig, and the 2.5 psig to 7.5 psig. The allowable drop of one pound and the timing remain the same). In no case shall the starting pressure exceed 9.0 psig.

### 3.6 TEST FAILURE

- A. If the section of pipe fails to pass the leakage and pressure test, or if there is any visible leakage, the Contractor shall locate, uncover and repair or replace the defective pipe fitting or joint and retest all at his own expense. Pipe will be considered passing only when the leakage does not exceed the above standard. Passing the test does not absolve the Contractor from his responsibility if leaks develop later within the period of warranty.

## POLYVINYL CHLORIDE GRAVITY PIPE

02622-6

3.7 CONTRACT CLOSEOUT

Provide in accordance with Section 01700.

END OF SECTION 02622

## SECTION 02721

### STORM DRAINAGE SYSTEM

#### PART 1 - GENERAL

##### 1.1 SUMMARY

- A. Provide all labor, materials, equipment and supervision necessary to complete the work specified in this Section or shown on the Contract Drawings, or both, but not limited to the following:
  - 1. Storm drain piping, fittings, accessories and bedding.
  - 2. Catch basins and catch basin frames and grates.
  - 3. Drain manholes and drain manhole frames and covers.

##### 1.2 RELATED SECTIONS

- A. Drawings and general provisions of the Contract, and:
  - 1. Section 02200 Earthwork
  - 2. Section 02140 Dewatering and Drainage

##### 1.3 SUBMITTALS

- A. Submit shop drawings and manufacturer's specifications and installation instructions for all pipe materials including flared end sections, precast concrete catch basins and drain manholes, manhole frames and covers and catch basin frames and grates. Include component construction, features, configuration, and dimensions.
- B. Each shipment of pipe, catch basins and metal castings shall be accompanied with the manufacturers notarized certificate that the materials meet the specification requirements.

##### 1.4 REFERENCES

- 1. ASTM C32-05 Sewer and Manhole Brick.
- 2. ASTM C62-08 Building Brick.
- 3. ASTM C76-08a Reinforced Concrete Culvert, Storm Drain, and Sewer Pipe.
- 4. ASTM C139-05 Concrete Masonry units for Construction of Catch Basins and Manholes.
- 5. ASTM C270-08a Mortar for Unit Masonry .

### STORM DRAINAGE SYSTEM

02721-1

6. ASTM C443-05a Joints for Circular Concrete Sewer and Culvert Pipe, Using Rubber Gaskets.
7. ASTM C478-08 Precast Reinforced Concrete Manhole Sections.

## PART 2 - PRODUCTS

### 2.1 PIPE MATERIALS

- A. Reinforce Concrete Pipe: ASTM C76, Class III (unless otherwise specified on the project drawings), modified bell and spigot compression gasket joints complying with ASTM C443.
- B. General: Ells, tees, reducing tees, wyes, couplings, increasers, crosses, transitions and end caps of same-type class of materials as piping unless otherwise indicated.

### 2.2 MANHOLES AND CATCH BASINS

- A. The material to be used in the construction of storm drain manholes, catch basins, and drop inlets shall conform to MHD Standard Specifications, the Drawings, and these specifications. Design depths as indicated on the Contract Drawings.
- B. Precast Concrete Manholes and Catch Basins: ASTM C478, eccentric cone, flat slab precast top; precast riser section and monolithic base section with integral floor.
- C. Concrete Compressive Strength: 4000 psi minimum. Type II cement.
- D. Reinforcing Steel: ASTM A185, 0.12 sq. in./linear ft. and 0.12 sq. in. (both ways) base bottom.
- E. Joints sealed with rubber gaskets conforming to ASTM C443.
- F. Steps: Forged 6061B, T6 aluminum or Copolymer Polypropylene Plastic with 1/2 inch Grade 50 steel reinforcement.
- G. PVC Structures: ASTM DI784, ASTM D2122 and ASTM D2564.
- H. Pipe Connectors: Provide a hydraulic cement, no shrink grout, which shall be made watertight with the RCP storm drainage pipe.

### 2.3 CAST IRON FRAME AND COVER

- A. Frame and Cover: Cast iron construction, manufactured by LeBaron Foundry, Inc. (East Jordan Iron Works, Inc).

## STORM DRAINAGE SYSTEM 02721-2

## 2.4 CAST IRON FRAME AND GRATE

- A. Frame and Grate: Manufactured by E.L. LeBaron (East Jordan Iron Works, Inc.) model #LF-248-2 flange (single or double) or approved equal.

## 2.5 OIL AND FLOATING DEBRIS TRAP

- A. Oil and Floating Debris Trap: Manufactured by Ground Water Rescue, Inc. model The Eliminator or approved equal.

## 2.6 MASONRY MATERIAL

- A. Concrete Masonry Units: ASTM CI39.
- B. Brick: ASTM C32 Grade MS or ASTM C62) Grade SW.
- C. Mortar: ASTM C270 Type M.

## 2.7 PIPE BEDDING AND COVER MATERIALS

- A. Bedding, Cover and Compaction Requirements: Fill Type as specified in Section 02200, and shown on the Details.

## 2.8 INFILTRATION BASIN

- A. Infiltration basin shall be pre cast concrete type, a min of 6 feet in diameter and a min 6 ft. deep. Concrete strength shall be 4,000 psi @ 28 days. Cement shall be Portland Type II per ASTM CI50-81. Steel reinforcement shall conform to ASTM A-615, Grade 60. Design loading per AASHO HS-10.
- B. Infiltration basin shall comply with the standards of the City of Waltham.

## PART 3 EXECUTION

### 3.1 EXAMINATION

- A. Verify that the trench cut and excavation base is ready to receive work and excavations, dimensions, and elevations are as indicated on Contract Drawings.

### 3.2 PREPARATION

- A. Hand trim excavations to required elevations. Correct over excavation with processed
- B. Remove large stones or other hard matter, which could damage piping, structures, or Impede consistent backfilling or compaction

## STORM DRAINAGE SYSTEM

02721-3

### 3.3 BEDDING

- A. Excavate for pipe trench or structure in accordance with Section 02200. Hand trim excavation for accurate placement of pipe and structures to elevations indicated on the Drawings.
- B. Place bedding material at trench bottom, level materials in continuous layer not exceeding 12 inches compacted depth.
- C. Maintain optimum moisture content of bedding material to attain required compaction density.

### 3.4 INSTALLATION- PIPE

- A. Install pipe, fittings, and accessories in accordance with ASTM D2321 and manufacturer's instructions. Seal joints watertight.
- B. Place pipe on minimum 12 inch deep bed in accordance with Section 02200.
- C. Lay pipe to slope gradients noted on drawings with maximum variation from true slope of 1/8 inch in 10 feet.
- D. Install processed gravel at sides to the midpoint of the pipe. Install Ordinary Borrow from the midpoint of the pipe to the elevations indicated on the Contract Drawings, compacted to 95 percent maximum density at optimum moisture content.
- E. Refer to Section 02200 for trenching and backfilling requirements. Do not displace or damage pipe when compacting.

### 3.5 INSTALLATION- CATCH BASINS AND DRAIN MANHOLES

- A. Form bottom of excavation clean and smooth to correct elevation.
- B. Install and level precast concrete manhole base and sections per the Details of the Drawings including 12" depth of crushed stone with filter fabric.
- C. Establish elevations and pipe inverts for inlets and outlets as indicated on the Drawings. D. Mount frame and cover or frame and grate level in grout, secured to top cone or flat top section to elevations indicated on the Drawings.

### 3.6 FIELD QUALITY CONTROL

- A. Request inspection prior to and immediately after placing aggregate cover over pipe.
- B. Compaction will be performed in accordance with Section 02200.

## STORM DRAINAGE SYSTEM

02721-4



3.7 PROTECTION

- A. Protect pipe and aggregate cover from damage or displacement until backfilling operation is in progress.

END OF SECTION 02721

STORM DRAINAGE SYSTEM  
02721-5

## SECTION 02901

### MISCELLANEOUS WORK AND CLEANUP

#### PART 1 - GENERAL

##### 1.1 SCOPE OF WORK

- A. Furnish all labor, materials, equipment and incidentals required to do the miscellaneous work not specified in other sections but obviously necessary for the proper completion of the work as shown on the Drawings.
- B. When applicable the Contractor shall perform the work in accordance with other sections of this Specification. When no applicable specification exists the Contractor shall perform the work in accordance with the best modern practice and/or as directed by the Engineer.
- C. The work of this Section includes, but is not limited to, the following:
  - 1. Installing and maintaining construction warning signs.
  - 2. Crossing and relocating existing utilities.
  - 3. Restoring of driveways and sidewalks.
  - 4. Cleaning up.
  - 5. Incidental work.
  - 6. Job photographs.
  - 7. Protection and/or removal and reinstallation of existing signs, lampposts, fence posts, fencing and mailboxes.
  - 8. Protection and bracing of utility poles.
  - 9. Restoration and replacement of curbing.
  - 10. Raking and re-seeding of grassed areas disturbed during construction and/or dewatering activities, including silt basin/dewatering activity areas.

#### PART 2 PRODUCTS

##### 2.1 MATERIALS

- A. Materials required for this Section shall be the same quality of materials that are to be restored. Where possible, the Contractor may re-use existing materials that are removed.

### MISCELLANEOUS WORK AND CLEANUP

02901-1

## PART 3- EXECUTION

### 3.1 INSTALLING AND MAINTAINING CONSTRUCTION WARNING SIGNS

- A. Construction work zone traffic control shall be the contractor's responsibility. Generally, conformance with Part VI of the Manual of Uniform Traffic Control Devices (MUTCD), latest edition, "Standards and Guides for Traffic Controls for Street and Highway Construction, Maintenance, Utility, and Incident Management Operations", will be considered to meet this requirement.

### 3.2 CROSSING AND RELOCATING EXISTING UTILITIES

- A. This Item includes any extra work required in crossing culverts, water courses, including brooks and drainage ditches, storm drains, gas mains, water mains, electric, telephone, gas and water services and other utilities. This work shall include but is not limited to the following: bracing, hand excavation and backfill (except screened gravel) and any other work required for crossing the utility or obstruction not included for payment in other items of this specification. Notification of Utility Companies shall be as specified in Section 01046.
- B. In locations where existing utilities cannot be crossed without interfering with the construction of the work as shown on the Drawings, the Contractor shall remove and relocate the utility as directed by the Engineer or cooperate with the Utility Companies concerned if they relocate their own utility.
- C. At pipe crossings and where designated by the Engineer, the Contractor shall furnish and place screened gravel bedding so that the existing utility or pipe is firmly supported for its entire exposed length. The bedding shall extend to the mid-diameter of the pipe crossed. Payment for screened gravel at pipe crossings will be made according to the unit price bid established in the Bid F01m.

### RESTORING OF DRIVEWAYS AND SIDEWALKS

- A. Existing public and private driveways disturbed by the construction shall be replaced. Paved drives shall be repaved to the limits and thickness existing prior to construction. Gravel drives shall be replaced and regraded.
- B. Existing public and private sidewalks disturbed by the construction shall be replaced with sidewalks of equal quality and dimension. In general, sidewalks shall be 2-1/2 inches thick after rolling and compacting and the material shall be top course bituminous asphalt.

### 3.4 CLEANING UP

- A. The Contractor shall remove all construction material, excess excavation, buildings, equipment and other debris remaining on the job as a result of construction operations and shall restore the site of the work to a neat and orderly condition. Any materials, and

## MISCELLANEOUS WORK AND CLEANUP

02901-2

sand or concrete materials shall be cleaned out of the manholes and catch basins. Haybales and siltfence as well as any silt and debris retained by same shall be removed.

### 3.5 INCIDENTAL WORK

- A. Do all incidental work not otherwise specified, but obviously necessary to the proper completion of the Contract as specified and as shown on the Drawings.

### 3.6 PHOTOGRAPHS OF PROJECT

- A. Prior to commencing work, Contractor may document existing conditions using construction photographs. Photographs for this purpose shall be at the Contractors' expense.

### 3.7 RESTORATION AND REPLACEMENT OF SIGNS, LAMPPOSTS, FENCE POSTS, FENCING, AND MAILBOXES

- A. Existing signs, lamp posts, fence posts, fencing and mailboxes which may be damaged by the Contractor or removed by the Contractor during the course of installing the new pipelines shall be reinstalled in a vertical position at the same location from which they were removed. Damaged items shall be replaced with an item equal to or better than the damaged items. A concrete anchor shall be provided as necessary, at no additional cost, to ensure a rigid alignment. Care shall be exercised in the reinstallation of all items to prevent damage to the newly installed pipelines.

### 3.8 RESTORATION AND REPLACEMENT OF CURBING

- A. Existing concrete, bituminous, timber or granite curbing shall be protected. If necessary, curbing shall be removed and replaced after backfilling. Curbing which is damaged during construction shall be replaced with curbing of equal quality and dimension at the Contractor's expense. Granite curbing removed and reset shall

### 3.9 PROTECTION AND BRACING OF UTILITY POLES

- A. The Contractor shall be responsible for making all arrangements with the proper utility companies for the bracing and protection of all utility poles that may be damaged or endangered by the Contractors operations. Work under this item shall include the related removal and reinstallation of guy wires, or support poles whether shown on the Drawings or not.

### 3.10 RAKING AND RE-SEEDING

- A. Grass and landscaped areas disturbed by the Contractor shall be raked and replenished with loam if required. Areas shall be re-seeded as required.

END OF SECTION 02901

## MISCELLANEOUS WORK AND CLEANUP 02901-3

## SECTION 02920

### TOPSOIL

#### PART 1 GENERAL

##### 1.1 SUMMARY

The work of this section consists of manufacturing, delivering, and placing 4" of Topsoil on all disturbed areas. Topsoil, as available, may be stripped, screened, stockpiled and tested for reuse. Topsoil requirements in excess of available amounts will be imported. Both sources will be placed in compliance with this section.

##### 1.2 RELATED SECTIONS

A. Drawings and general provisions of the Contract, including General and Supplementary Conditions and Division 1 Specification Sections, apply to this section and:

1. Section 02200- Earthwork

##### 1.3 SUBMITTALS

In accordance with Section-01300. Submit soil analysis report for imported topsoil from the State University Agricultural Extension Service or other approved soil testing laboratory. Report shall cover soil textural classification (percentages of sand, silt, and clay) and include additive recommendations for lawn areas and plantings. Field methods of analysis are acceptable, but laboratory report is preferred.

##### 1.4 PRODUCT HANDLING

Do not deliver topsoil in frozen, wet, or muddy condition.

#### PART 2- MATERIALS

##### 2.1 IMPORTED TOPSOIL

- A. Friable loam, typical of fertile local topsoil; free-from pure clay, weeds, noxious weed seeds, sod, clods and stones larger than 1 inch, toxic substances, litter, or other deleterious material; having a mildly alkaline to medium acid pH between 6.0 and 7.5. Soluble salts shall not exceed 4 milli-mhos per centimeter.
- B. Soil Texture: 20 to 40% fines (silt and clay fraction passing the 200 sieve) and 60 to 80% Sand and gravel. The maximum particle size shall be 1 inch.
- C. Organic Content: 5 to 10%.
- D. Additive: As required by soil analysis..

TOPSOIL  
02920-1

PART 3- EXECUTION

3.1 PLACING TOPSOIL

- A. Scarify compacted subgrade to a 2-inch depth to bond topsoil to subsoil. Place topsoil to a minimum depth of 4 inches for disturbed areas. Spread evenly and grade to elevations and slopes shown. Hand rake areas inaccessible to machine grading.

END OF SECTION 02920

## SECTION 02945

### TURF

#### PART 1 – GENERAL

##### 1.1 SUMMARY

- A. The work of this Section consists of providing all labor, equipment, materials, incidental work, and construction methods necessary to perform all lawn installation and fine grading work and related items as indicated on the Contract Documents and/or specified in this Section and includes, but is not necessarily limited to, the following:
  - 1. Seeding
  - 2. Laying sod
  - 3. Maintenance and protection

##### 1.2 RELATED DOCUMENTS

- A. The General; Documents, as listed on the Table of Contents, and applicable parts of Division I, GENERAL REQUIREMENTS, shall be included in and made a part of this Section. .
- B. Examine all Contract Documents and all other Sections of the Specifications for requirements therein affecting the work of this trade.
- C. The following items of related work are specified and included in other Sections of the Specifications:
  - 1. Section 02920- Topsoil

##### 1.3 SUBMITTALS

- A. At least 90 days prior to the first day of the seeding/sodding season described in this Section, submit to the Engineer proof of certification of Foreman or Crew Leader as Massachusetts Certified Land scape Professional or Massachusetts Certified Horticulturist in accordance with QUALITY ASSURANCE paragraph of this Section.
- B. Submit proof of landscape contractor’s experience to the Engineer in accordance with QUALITY ASSURANCE paragraph of this Section.
- C. At least 30 days prior to intended use, the Contractor shall provide the following samples and submittals for approval in conformance with the requirements of Division 1 Section, SUBMITTALS. Do not order materials until Engineer’s approval of samples, certifications or test results has been obtained. Delivered materials shall closely match the approved samples. Acceptance shall not constitute final acceptance. The Engineer

TURF  
02945-1

reserves the right to reject on or after delivery any material that does not meet these Specifications.

1. Material Sampling and Testing of Loam Borrow from Off-Site Sources shall be specified and performed under Division 2 Section, TOPSOIL, of this Specification.
  2. Fertilizer:
    - a. Submit product literature of seeding fertilizer and certificates showing composition and analysis.
    - b. Submit the purchasing receipt showing the total quantity purchased for the project prior to installation.
  3. Seed: Submit a manufacturer's Certificate of Compliance to the Specifications with each shipment of each type of seed. These certificates shall include the guaranteed percentages of purity, weed content and germination of the seed, and also the net weight and date of shipment. No seed may be sown until the Contractor has submitted the certificates.
  4. Hydroseeding: Prior to the start of hydroseeding, submit a certified statement for approval as to the number of pounds of materials to be used per 100 gallons of water.
  5. Wood Cellulose Fiber Mulch: Submit 4 copies of manufacturer's literature and one material sample.
  6. Sod: Prior to the start of laying sod on the Baseball Field Infield, request approval from Engineer of 4' long sod strip. Sod sample must be from the same delivery as the sod which is to be laid. Engineer must be given at least 48 hours of notice before the sod is expected to be delivered to the site.
  7. Limestone: Submit supplier's certification that the limestone being supplied conforms to these Specifications.
  8. All additives needed to amend a specific soil in order to meet these specifications.
- D. Maintenance Instructions: At the time of Acceptance, the Contractor shall submit complete maintenance instructions for turf care for the Owner's use. The instructions shall be reviewed for approval by the Engineer as a pre-condition for Acceptance.

#### 1.4 EXAMINATION OF CONDITIONS

- A. All areas to be improved shall be inspected by the Contractor before starting work and any defects such as incorrect grading, or drainage problems shall be reported to the Engineer prior to beginning this work. The commencement of work by the Contractor

TURF  
02945-2



shall indicate his acceptance of the areas to be improved, and he shall assume full responsibility for the work of this Division 2 Section, TURF.

- B. The Contractor shall be solely responsible for judging the full extent of requirements involved.

## 1.5 QUALITY ASSURANCE

- A. Qualification of Landscape Contractor: The work of this Division 2 Section, TURF, shall be performed by a landscape contracting firm which has successfully installed work of a similar quality, schedule requirement, and construction detailing with a minimum of five years experience. Proof of this experience shall be submitted per SUBMITTALS paragraph of this Division 2 Section, TURF.
- B. Qualification of Foreman or Crew Leader: All work of seeding/sodding shall be supervised by a foreman or crew leader who is a certified landscape professional or a certified horticulturist.
  - 1. Landscape professional shall be a Massachusetts Certified Landscape Professional certified by the Associated Landscape Contractors of Massachusetts.
  - 2. Horticulturist shall be a Massachusetts Certified Horticulturist as certified by the Massachusetts Nursery and Landscape Association.
  - 3. Certification shall be current. Proof of certification shall be submitted per SUBMITTALS paragraph of this Division 2 Section, TURF.
- C. The ratio of laborers to certified landscape professionals or certified horticulturist shall not exceed twelve to one. Certified Landscape Professional or Certified Horticulturist shall be on the project site throughout the day to day performance of the work described in this Division 2 Section, TURF.

## PART 2- PRODUCTS

### 2.1 LOAM

- A. Loam borrow shall be specified, provided, installed and paid for under the work of the Division 2 Section, TOPSOIL, of this Specification.

### 2.2 SOIL ADDITIVES

- A. Soil additives shall be specified, provided and paid under Division 2 Section, TOPSOIL, except for additional applications of fertilizer that shall be specified, provided and paid for under this Division 2 Section, TURF, based upon recommendations from soil analysis and testing as specified.

TURF  
02945-3

2.3 SEED

A. Seed mixture shall be fresh, clean, new crop seed. Grass shall be of the previous year's crop and in no case shall the weed seed content exceed 0.25% by weight. The seed shall be furnished and delivered in the proportion specified below in new, clean, sealed and properly labeled containers. All seed shall comply with State and Federal seed laws. Submit manufacturer's Certificates of Compliance. Seed that has become wet, moldy or otherwise damaged shall not be acceptable. Tall fescue and ryegrass shall contain Acromonium endophytes. Seed containing endophyte must be kept cool and dry at all times; do not stockpile in the sun.

1. Seed Mixture Composition for baseball outfield, athletic field surrounds and disturbed areas:

<u>Common Name</u>	<u>Proportion By Weight</u>	<u>Germination Minimum</u>	<u>Purity Minimum</u>
Tall Fescue (3 varieties minimum)	80%	85%	95%
Kentucky Bluegrass	10%	85%	95%
Perennial Rye	10%	90%	95%

a. All grass varieties shall be within the top 50 percent of varieties tested in National Turfgrass Evaluation Program, or currently recommended as low maintenance varieties by University of Massachusetts or the University of Rhode Island.

b. Seeding rate shall be 6 pounds per 1,000 square feet.

B. Seed may be mixed by an approved method on the site or may be mixed by a dealer. If the seed is mixed on the site, each variety shall be delivered in the original containers that shall bear the dealer's guaranteed analysis. If seed is mixed by a dealer then the Contractor shall furnish the Engineer the dealer's guaranteed statement of the composition of the mixture.

2.4 SOD

A. Sod for the baseball infield shall be nursery grown sod grown from the following seed mixtures and in accordance with percentages as specified:

1. Seed Mixture Composition for Baseball Infield Area:

<u>Common Name</u>	<u>Proportion By Weight</u>	<u>Germination Minimum</u>	<u>Purity Minimum</u>
Tall Fescue (3 varieties minimum)	80%	85%	95%
Kentucky Bluegrass	10%	85%	95%

Perennial Ryegrass 10% 90% 95%

- a. All grass varieties shall be within the top 50 percent of varieties tested in National Turfgrass Evaluation Program, or currently recommended as low maintenance varieties by University of Massachusetts or the University of Rhode Island.
- B. Sod shall be machine cut from an established sod farm specializing in the production and harvesting of top quality, grass turf products. Sod shall be machine cut at a uniform soil thickness of 3/4-inch +/- 1 /8 inch, at the lime of cutting. Measurement for thickness shall exclude top growth and thatch. Individual pieces of sod shall be cut to the supplier's standard width and length. Maximum allowable deviation from standard widths and lengths shall be 5 percent. Broken pads and torn or uneven end will not be acceptable. Sod shall be at least one year old from time of original seeding..
- C. Sod shall be free of grass species other than those specified in this Division 2 Section, TURF. Sod shall be free of weeds.
- D. Sod shall be furnished and installed in rectangular sod strips measuring 12 inches or 16 inches in width and from 4 feet to 6 feet in length, stored in rolls with the grass top side inverted so that the topsoil is to the exterior.
- E. Sod shall be harvested, delivered and installed within a period of 36 hours. Soil on sod pads shall be kept moist at all times.
- F. Stakes: Stakes for pegging the sod shall be sound hardwood approximately one inch by 2 inches and of sufficient length to penetrate the mat, the seed bed and to a minimum depth of 2 inches of subsoil. Stakes shall be free from insects and fungi and capable of remaining in the ground at least 2 years.
- G. Sod delivered to the construction site which does not conform to the requirements of this Division 2 Section, TURF, will be rejected by the Engineer and shall be removed from the site by the Contractor at no additional cost to the Owner. Sod found to contain unacceptable levels of unspecified grass species or weed species at any time up to and including Final Acceptance will be rejected by the Engineer. Contractor shall remove sod from the site and shall replace unacceptable sod with new, approved sod at no additional cost to the Owner. The Engineer shall be the sole judge of what constitutes acceptable or unacceptable levels of unspecified grass species or weed species.

2.5 FERTILIZERS

- A. Fertilizer shall be a commercial product complying with the State and United States fertilizer laws. Deliver to the site in the original unopened containers that shall bear the manufacturer's certificate of compliance covering analysis. Fertilizer shall contain not less than the percentages of weight of ingredients as recommended by the soil analysis specified, performed and paid for under the Division 2 Section, TOPSOIL, of this Specification.

2.6 LIMESTONE

- A. Ground limestone for adjustment of loam borrow pH shall contain not less than 85 percent of total carbonates and shall be ground to such fineness that 40 percent will pass through 100 mesh sieve and 95 percent will through a 20 mesh sieve. Contractor shall

TURF  
02945-5

beaware of loam borrow pH and the amount of lime needed to adjust pH to specification inaccordance with testing lab recommendations.

## 2.7 WOOD CELLULOSE FIBER MULCH

- A. Mulch to cover hydroseeded areas with slopes less than 3 to 1 shall be fiber processed from whole wood chips and clean recycled newsprint in a 1:1 proportion manufactured specifically for standard hydraulic mulching equipment. Fiber shall not be produced from recycled material such as sawdust, paper, or cardboard.
- B. Moisture content shall not exceed 10 percent, plus or minus 3 percent as defined by the pulp and paper industry standards. Fiber shall have a water holding capacity of not less than 900 grams water per 100 grams fiber.
- C. The mulch shall be of such character that the fiber will be dispersed into a uniform slurry when mixed with water. It shall be nontoxic to plant life or animal life.
- D. The mulch shall contain a non-petroleum based organic tackifier and a green dye to allow for easy visual metering during application but shall be non-injurious to plant growth.

## 2.8 HERBICIDES, CHEMICALS AND INSECTICIDES

- A. Provide chemicals and insecticides as needed for fungus or pest control. All chemicals and insecticides shall be approved by the Massachusetts Department of Food and Agriculture for the intended uses and application rates.
- B. Provide post-emergent crab grass control throughout the maintenance period to ensure a germinated and mown lawn free of crab grass.

## 2.9 WATER

- A. The Contractor may use water provided by the City upon request and approval of the DPW, if available. The Contractor shall responsible to furnish his own supply of water to the site at no additional cost to the Owner. If City water is not available, the Contractor shall be responsible to furnish adequate supplies at his own cost. All work injured or damaged due to the lack of water or use of too much water, shall be the Contractor's responsibility to correct. Water shall be free from impurities injurious to vegetation. The Contractor's use of City water shall be at his own risk.

## PART 3- EXECUTION

### 3.1 FILLING AND COMPACTION

- A. Filling and compaction of loam shall be specified, performed and paid for under the work of the Division 2 Section, TOPSOIL, of this Specification.

### 3.2 FINE GRADING

- A. Fine grading shall be specified, performed and paid for under the work of the Division 2 Sections, Earthwork, Rough Grading and Topsoil, if this Specification..

### 3.3 SEEDING

- A. Contractor shall obtain Engineer's written approval of fine grading and bed preparation

TURF  
02945-6

- before doing any seeding.
- B. Limit of work shall be limit of seeding unless otherwise indicated on the Contract Documents. All lawn areas disturbed outside the limit of seeding shall be prepared and seeded as specified herein at no additional cost.
  - C. The season for seeding shall be from April 1 to May 31 and from August 15 to September 30. The actual planting of seed shall be done, however, only during periods within this season which are normal for such work as determined by weather conditions and by accepted practice in this locality. To prevent loss of soil via water and wind erosion and to prevent the flow of sediment, fertilizer, and pesticides onto roadways, sidewalks, and into catch basins, seed loam areas within 5 Days of spreading the loam.
  - D. Seed only when the bed is in a friable condition, not muddy or hard.
  - E. Seeding of Disturbed areas and Athletic Field areas shall be by Hydroseeding Method specified as follows:
    - 1. Prior to the start of work, furnish a certified statement as to the number of pounds of materials to be used per 100 gallons of water. This statement shall also specify the number of square feet of hydroseeding that can be covered with the quantity of solution in the hydroseeder.
    - 2. Hydroseed with wood cellulose fiber mulch at a rate as designated above in Part 2 - PRODUCTS.
    - 3. For the hydroseeding process, a mobile tank with a capacity of at least 500 gallons shall be filled with water and the mixture noted above in the specified proportions. The resulting slurry shall be thoroughly mixed by means of positive agitation in the tank. Apply the slurry by a centrifugal pump using the hose application techniques from the mobile tank. Only hose application shall be permitted. At no time shall the mobile tank or tank truck be allowed onto the prepared hydroseed beds. The hose shall be equipped with a nozzle of a proper design to ensure even distribution of the hydroseeding slurry over the area to be hydroseeded and shall be operated by a person thoroughly familiar with this type of seeding operation.
    - 4. Contractor shall obtain Engineer's written approval of fine grading and bed preparation before doing any hydroseeding.
    - 5. Limit of work shall be limit of hydroseeding unless otherwise indicated on the Contract Documents. All lawn areas disturbed outside the limit of hydroseeding shall be hydroseeded.
    - 6. Seed only when the bed is in a friable condition, not muddy or hard. Construction methods shall conform to hydraulic method requirements specified in the Standard Specification.
    - 7. Hydroseeding shall be a two-step process.

TURF  
02945-7

- a. Step one shall consist of spreading 100 percent of the required seed uniformly over the prepared loan1 bed so that the seed comes into direct contact with the soil. To mark the progress of the hydroseeding operation the Contractor may add 10 percent of the wood cellulose fiber mulch to the slurry.
- b. Step two shall consist of a separate application of wood cellulose fiber mulch immediately following the first step of hydroseeding noted above. Apply the wood cellulose fiber mulch at a rate of 2,000 pounds per acre.

### 3.4 SODDING

- A. The season for laying sod shall be from April 1 to May 31 and from August 15 to September 30. The actual lawn construction work shall be done, however, only during periods within this season that are normal for such work as determined by weather conditions and by accepted practice in this locality. At his option, and on his own responsibility, the Contractor may proceed under unseasonable conditions without additional compensation, but subject to Engineer's approval of time and methods.
- B. Immediately prior to sod laying operations, the loam bed shall be lightly scratched with a fine toothed harrow or hand rake to provide a slightly roughened surface to accept the sod application.
- C. The soil on which the sod is laid shall be reasonably moist and shall be watered, if necessary. The sod shall be laid smoothly, edge to edge, and where continuous is called for on the plans sod shall be laid with the longest dimension parallel to the contours. Laying of sod shall start at the base of slopes and progress upwards in continuous parallel rows. Vertical joints between sods shall be staggered. immediately after laying, press the sod firmly into contact with the soil bed by tamping, rolling, or by other approved methods so as to eliminate all air pockets. Provide true and even surfaces,, insure knitting and protect all exposed sod edges, but without displacement of the sod or deformation of the sod surface.
- D. In all swales, and on all slopes steeper than or equal to three to one (3:1) and elsewhere as specified or as directed by the Engineer, sods shall be held in place by stakes. Stakes shall be untreated wood one inch by two inches by twelve inches long. Staking shall be done immediately after tamping. At least one stake shall be driven through each sod to be pegged and the stakes shall be not more than two feet apart. Stakes shall have their flat sides against the slope and be driven flush.
- E. Immediately after laying sod and until the sod had knitted to the soil (a minimum of seven days following the installation), sod shall be watered with 1" of water. After the sod has knitted to the soil {from 1-3 weeks) it is important to continue to soak the root zone (top 4-5 inches of soil). Provide 1 inch of water every 2-3 days, dependent on soil, temperatures and rainfall.

### 3.5 TURF MAINTENANCE

- A. Maintenance shall begin immediately after any area is seeded or sodded and shall continue for a 60 day active growing period for seeded areas or until Final Acceptance, whichever is longer following the completion of all lawn construction work and until

TURF  
02945-8

final acceptance of the project. In the event that seeding operations are completed too late in the Fall for adequate germination and growth of grass, then maintenance shall continue into the following Spring for the minimum 60 Day period and including the One (1) Year Maintenance Period.

- B. Maintenance shall include re-seeding or relaying sod, two (2) mowings, watering, weeding, fertilizing a minimum of two times in addition to the fertilizer incorporated by harrowing into the spread loam, and resetting and straightening of protective barriers. Lawn work maintenance shall also include chemical treatments as required for fungus and/or pest control
- C. During the maintenance period, any decline in the condition of turf areas shall require immediate action to identify potential problems and to undertake corrective measures.
- D. Watering shall be done in a manner that will provide uniform coverage, prevent erosion due to application of excessive quantities over small areas, and prevent damage to the finished surface by the watering equipment.
  - 1. The Contractor shall provide all labor and arrange for all watering necessary to establish an acceptable lawn. In the absence of adequate rainfall, watering shall be performed daily or as often as necessary to maintain moist soil to a depth of at least two (2) inches for seeded areas and four (4) inches for sodded areas. At no time shall a tank truck be allowed on the reseeded/re-sodded beds.
  - 2. Watering shall be done in a manner that will provide uniform coverage, prevent erosion due to application of excessive quantities over small areas, and prevent damage to the finished surface by the watering equipment. The Contractor shall furnish sufficient watering equipment to apply water to the required soil depths each 8-hour period.
- E. After the grass in seeded areas has germinated, reseed all areas and parts of areas that fail to show a uniform stand of grass. Reseed such areas and parts of areas repeatedly until all areas are covered with a satisfactory growth of grass with no less than 20 grass shoots per square inch and 2880 grass shoots per square foot. Reseeding together with necessary grading, fertilizing, and trimming shall be done at the Contractor's expense.
- F. All sod shall have become established. Dead portions of sod shall be removed and replaced. All joints between sod pieces shall be filled with loam. All pieces of sod shall have knit to loam.
- G. Mowing and Edging:
  - 1. The Contractor shall keep lawn areas mowed until Acceptance of the contract by cutting to a height of two (2) inches when growth reaches three (3) inches or as directed by the Engineer.
  - 2. At each mowing, all edges of walks, drives, plant beds and other border conditions shall be edge trimmed by hand or machine to produce straight and uniform edge conditions.

TURF  
02945-9

3. Remove and discard from paved areas only clippings and debris generated by each mowing and edging operation legally off-site. Engineer, if practical and aesthetic, may allow sweeping (not blowing) clippings back into grass. Mowers shall be equipped with mulching blades. Do not remove from grass areas any clippings that have been generated by mowing operations. Do not mow grass when wet.

H. Fertilizing for seeded lawns: The first application of fertilizer is specified, provided, performed and paid for under the Division 2 Section, TOPSOIL. A second application of fertilizer shall be applied to seeded areas at the time of the first mowing and shall be performed and paid for under this Division 2 Section, TURF. This second application shall be applied at a rate that ensures that one-half pound of nitrogen is applied per 1,000 square feet. Phosphorus and potassium shall be applied proportionally in accordance with the recommendations of the soil tests and the quantities previously integrated into the soil during the first application. A third application of nitrogen fertilizer shall be applied to seeded areas approximately two months after the second application and shall be paid for under this Division 2 Section, TURF. This third application shall correspond to the following application rates dependent upon the month of application.

1. May 1-15: Apply 1.0 pound of nitrogen per 1,000 square feet.
2. June 15-30: Apply 1.0 pound of nitrogen per 1,000 square feet.
3. August 15 through September 15: Apply 1.0 pound of nitrogen per 1,000 square feet.
4. November 1-15: Apply 1.5 pounds of nitrogen per 1,000 square feet.

\*\*Nitrogen fertilizer shall be composed of 50 percent slowly soluble or slow release nitrogen fertilizer.

I. Fertilizing for sodded areas: The first application of fertilizer is specified, provided, performed and paid for under the Division 2 Section, TOPSOIL. A second application of nitrogen fertilizer shall be applied to sodded areas approximately two months after the sod is installed and shall be performed and paid for under this Division 2 Section, TURF. Phosphorus and potassium shall be applied proportionally in accordance with the recommendations of the soil tests and the quantities previously integrated into the soil after the first application. This second application shall correspond to the following application rates dependent upon the month of application.

1. May 1-15: Apply 1.0 pound of nitrogen per 1,000 square feet.
2. June 15-30: Apply 1.0 pound of nitrogen per 1,000 square feet.
3. August 15 September 15: Apply 1.0 pound of nitrogen per 1,000 square feet.
4. November 1-15: Apply 1.5 pounds of nitrogen per 1,000 square feet.

\*\*Nitrogen fertilizer shall be composed of 50 percent slowly soluble or slow release nitrogen fertilizer.

TURF  
02945-10



### 3.6 APPLYING LIMESTONE

- A. The Contractor shall return to the site at the beginning of the next seeding/sodding season as specified above and spread limestone across all lawn areas installed under this Contract. The work of liming the fields shall be as specified under Division 2 Section, TOPSOIL, of this Specification, and performed and paid for under this Division 2 Section, TURF. Limestone shall be spread at rates determined by the soil tests specified.

### 3.7 ACCEPTANCE

- A. Following the minimum required maintenance periods for lawn construction, the Contractor shall request the Engineer in writing for a formal inspection of the completed work. Request for inspection shall be received by the Engineer at least 10 Days before anticipated date of inspection.
- B. Acceptance Requirements:
  - 1. At the end of the maintenance period, seeded and sodded areas shall have a close stand of grass as defined above with no weeds present and no bare spots greater than 3 inches in diameter over greater than 5 percent of the overall seeded area. At least 90 percent of the grass established shall be permanent grass species. If seeded areas are deficient, the Contractor's responsibility for maintenance of all seeded areas shall be extended until deficiencies are corrected. Seeded areas to be corrected shall be prepared and reseeded in accordance with the requirements of this Division 2 Section, TURF.
  - 2. Sodded areas shall be in vigorous growing condition with no discolored, dead or otherwise unacceptable areas. Sod will have knit firmly to the loam subgrade and no weeds shall be present.
- C. Furnish full and complete written instructions for maintenance of the lawns to the Owner at the time of acceptance in conformance with Submittals requirements.
- D. Engineer's inspection shall determine whether maintenance shall continue in any part.

### 3.8 CLEANUP

- A. Absolutely no debris may be left on the site. Excavated material shall be removed as directed. Repair any damage to site or structures to restore them to their original condition, as directed the Engineer, at no cost to the Owner

END OF SECTION 02945

## SECTION 02950

### PLANTING

#### PART 1 - GENERAL

##### 1.1 SUMMARY

- A. The work of this Section consists of providing all labor, equipment, materials incidental work, and construction methods necessary to perform all planting work and related items as indicated on the Contract Documents and as specified in this Section and includes, but is not limited to, the following:
  - 1. Planting trees.
  - 2. Staking, guying, and anchoring trees.
  - 3. Planting maintenance.
  - 4. One year guarantee period for all plants.
  - 5. Providing and placing backfill mix

##### 1.2 RELATED DOCUMENTS

- A. The General Documents, as listed on the Table of Contents and applicable parts of Division 1, GENERAL REQUIREMENTS, shall be included in and made a part of this Section.
- B. Examine all Contract Documents and all other Sections of the Specifications for requirements therein affecting the work of this trade.
- C. The following items of related work are specified and included in other Sections of the Specifications:
  - 1. Section 02200- Earthwork
  - 2. Section 02920 -Topsoil

##### 1.3 REFERENCES

- A. The following standards shall apply to the work of this Section.
  - 1. Hortus III, 1976, L. H. Bailey Hortorium.
  - 2. Tree and Shrub Transplanting Manual, E.B Himelick, 1991, International Society of Arboriculture.
  - 3. American National Standards Institute (ANSI):

### PLANTING 02950-1

Z60.1 American Standard for Nursery Stock, latest edition, published by American Nursery & Landscape Association, (ANLA).

#### 1.4 SUBMITTALS

- A. At least 90 days prior to the first day of the planting season described in this Division 2 Section, PLANTING, submit to the Engineer proof of certification of Foreman or Crew Leader as Massachusetts Certified Landscape Professional or Massachusetts Certified Horticulturist in accordance with QUALITY ASSURANCE paragraph of this Section.
- B. Submit proof of landscape contractor's experience to the Landscape Architect in accordance with QUALITY ASSURANCE paragraph of this Division 2 Section, PLANTING.
- C. At least 30 days prior to ordering materials, the Contractor shall submit to the Engineer representative samples, certifications, manufacturer's product data and certified test results for materials as specified below. No materials shall be ordered or delivered until the required submittals have been reviewed and approved by the Engineer. Delivered materials shall closely match the approved samples. Approval shall not constitute final acceptance. The Engineer reserves the right to reject, on or after delivery, any material which does not meet these Specifications.
- D. Material Sampling and Testing:
  - 1. Material Sampling and Testing of Loam Borrow from Off-Site Sources shall be specified, performed and paid for under the work of the Division 2 Section TOPSOIL, of this Specification. Testing of the off-site loam borrow shall occur in-place after the loam has been spread and represents a second testing of the off-site loam borrow. The first sampling and testing shall have occurred prior to delivery of the loam as specified, performed and paid for under the work of the Division 2 Section TOPSOIL, of this Specification. Additional sampling and testing of delivered and stockpiled loam or delivered and spread loam to verify that it meets the test results submitted for approval under the Division 2 Section TOPSOIL, shall not be abrogated by the language of this Division 2 Section, PLANTING.
  - 2. Material Sampling and Testing of Off-Site Loam: Off-site loam shall be sampled and tested as specified, performed and paid for under the Division 2 Section, TOPSOIL, of this Specification.
  - 3. Planting Mulch: Submit a one cubic foot sample.
  - 4. Antidesiccant: Submit manufacturer's product data.
  - 5. Peat: Submit a one cubic foot sample and manufacturer's certification of contents..
  - 6. Mycorrhizal Fungal Inoculant:
    - a. Submit manufacturer's product data certifying that inoculant being supplied conforms to these Specifications.

PLANTING  
02950-2

- b. Submit the purchasing receipt showing the total quantity purchased for the Project prior to installation.
  - c. Submit empty packets of fungal spore inoculant to the Engineer for verification of use.
7. Tree Staking System: Submit manufacturer's product data of system.
8. Soil Additives: Submit manufacturer's product data for all soil additives needed to amend a specific soil in order to meet the requirements of this Division 2 Section, PLANTING.

#### 1.5 EXAMINATION OF CONDITIONS

- A. All areas to be planted shall be inspected by the Contractor before starting work and any defects such as incorrect grading or inadequate drainage shall be reported to the Engineer prior to beginning this work.
- B. The Contractor shall be solely responsible for judging the full extent of work requirements involved, including but not limited to the potential need for storing and maintaining plants temporarily and/or re-handling plants prior to final installation.
- C. All plants are the full responsibility of the Contractor between the time of digging at the nursery and final acceptance.

#### 1.6 QUALITY ASSURANCE

- A. Qualification of Landscape Contractor: The work of this Division 2 Section, PLANTING, shall be performed by a landscape contracting firm which has successfully installed work of a similar quality, schedule requirement, and construction detailing with a minimum of five years experience. Proof of this experience shall be submitted per SUBMITTALS paragraph of this Division 2 Section, PLANTING.
- B. Qualification of Foreman or Crew Leader: All work of unloading, stockpiling, storing, transporting on-site, planting, staking and guying, fertilizing, and maintenance of trees, shrubs, vines, groundcover, and perennials shall be supervised by a foreman or crew leader who is a certified landscape professional or a certified horticulturist.
  - 1. Landscape professional shall be a Massachusetts Certified Landscape Professional certified by the Associated Landscape Contractors of Massachusetts.
  - 2. Certification shall be current. Proof of certification shall be submitted per SUBMITTALS paragraph of this Division 2 Section, PLANTING.
- C. The ratio of laborers to certified landscape professionals or certified horticulturist shall not exceed twelve to one. Certified Landscape Professional or Certified Horticulturist shall be on the project site throughout the day to day performance of the work described in this Division 2 Section, PLANTING.

## PART 2 -PRODUCTS

### PLANTING 02950-3

## 2.1 LOAM BORROW

- A. Loam borrow for planting shall be specified and provided under the work of the Division 2 Section, TOPSOIL, of this Specification.

## 2.2 SOIL ADDITIVES

- A. Soil additives shall be specified and provided for under Division 2 Section, TOPSOIL this Specification.

## 2.3 GRADES AND STANDARDS OF PLANTS

- A. The Contractor shall furnish all plants damaged by his work. No substitutions will be permitted, without written approval by the Engineer. All plants shall be nursery grown.
- B. All plants shall be typical of their species or variety and shall have a normal habit of growth and be legibly tagged with the proper name. Only plant stock grown within Hardiness Zones 1 through 6b, as established by the USDA Plant Hardiness Zone Map, latest edition, will be accepted.
- C. Plants shall be in accordance with ASNS Standards of the American Nursery & Landscape Association except as noted in this Division 2 Section, PLANTING. Botanical plant names shall be in accordance with plant designations included in Hortus III.
- D. If, at any time during the performance of the Contract, any plant shows signs of graft incompatibility, as determined by the Engineer, then the tree or shrub and all other similarly grafted plants of the same Genus/Species/Variety shall be rejected and removed from the site. Visual symptoms of graft incompatibility as cause for rejection include:
  - 1. Development of over-growths by rootstock or scion resulting in the development of shoulders or inverted shoulders.
  - 2. Suckering of the rootstock combined with poor growth or dieback of scion.
  - 3. Any mechanical weakness between scion and rootstock.
  - 4. Any marked difference in bark pattern and structure between scion and rootstock.
- E. All shrubs shall meet the following standards:
  - 1. All shrubs be healthy and vigorous plants which are very well shaped, heavily branched densely foliated, and true to form for the variety.
  - 2. Canes or Trunk(s) and Branches:
    - a. Well formed and sturdy.
    - b. Branching shall be uniformly distributed close to the ground.
    - c. Scars shall be free of rot and not exceed 1/4 the diameter of the wood beneath in greatest dimension unless completely healed (except pruning scars).

## PLANTING 02950-4

- d. Pruning scars shall be clean cut and shall leave little or no protrusion from the trunk or branch.
  - e. Graft unions shall be completely healed.
  - f. No suckers or water sprouts.
  - g. Contain no dead wood.
  - h. Free of cracks, splits, or cambium peeling.
- 3. No shrub with pest or mechanical damage will be accepted.
  - 4. Shrubs shall show no signs of frost or winter damage to the foliage. Foliage shall not be in a state of drought stress. Leaves or needles shall show no signs of wilt or desiccation due to weather stress at any season of the year.

## 2.4 ROOT SYSTEMS FOR ALL PLANTS

- A. Each plant shall have an extensive, symmetrically balanced fibrous root system. Any root ball which shows signs of asymmetry, girdling, injury, or damage to the root system shall be rejected.
- B. Curling or spiraling of the roots along the walls of rigid containers will not be accepted. Curling, spiraling or girdling roots within balled and burlapped material will not be accepted.
- C. All parts of the fibrous root system of all plants shall be moist and fresh with a white color when washed of soil. When the plant is removed from the container, the visible root mass shall be healthy with white root tips. The root systems of all plants shall be free of disease, insect pests, eggs, or larvae.
- D. All trees, and all shrubs which are not grown in containers must be moved with the root systems as solid units with balls of earth firmly wrapped with untreated 8 ounce natural, biodegradable fabric burlap, firmly laced with stout, natural biodegradable cord or twine. The base of the tree trunks shall be wrapped with a protective burlap layer, surrounded by a cardboard trunk protector, and loosely tied with twine.
- E. The diameter and depth of the balls of earth must encompass the fibrous and root feeding system necessary for the healthy recovery of the plant. Minimum root ball diameters and depths shall be in accordance with ASNS standards.
- F. No plants shall be loose in the container.
- G. Container grown plants which have roots growing out of the container will be rejected.

## 2.5 PLANTING SOIL MIX

- A. Planting soil mix shall be an approved loam borrow specified and provided for under the Division 2 Section, TOPSOIL, of this Specification and that has been pH adjusted according to particular planting applications and improved through the addition of organic matter as directed below. Planting loam shall conform to the following pH levels:

### PLANTING 02950-5

1. For broad-leaved evergreens and plants of the Heath Family, Ericaceae, requiring an acid soil, planting soil mix shall have a true pH of 4.5 to 5.5. Planting soil mix shall be amended by the Contractor at his own expense to the proper pH range by mixing with sulfur as specified under the Division 2 Section, TOPSOIL, of this Specification. Plants belonging to the Heath Family include but are not limited to the following genera: Arctostaphylos, Calluna, Chamaedaphne, Enkianthus, Epigaea, Erica, Gaultheria, Gaylussacia, Kalmia, Oxydendron, Pieris, Rhododendron, Vaccinium, and Zenobia.
2. Planting soil mix for general planting of non-acid loving plants shall have a true pH value of 6.0 to 6.5. Planting soil mix shall be amended by the Contractor at his own expense to the proper pH range by mixing with dolomitic limestone as specified under the Division 2 Section, TOPSOIL, of this Specification.
3. The amount of either sulfur or limestone required to adjust the planting soil mix to the proper pH range shall be approved by the Landscape Architect on the basis of soil tests as specified, under the Division 2 Section, TOPSOIL, of this Specification.

## 2.6 MULCH

- A. Bark Mulch: Mulch shall be high quality, double-ground, premium pine bark mulch of 70 percent hemlock bark with the balance spruce and pine bark. Mulch shall have been aged for a minimum of six months and not longer than two years. Bark mulch shall be shredded to a uniform size; free of dirt, debris and foreign matter; with pieces no thicker than 1 1/4 in. Mulch must be free of stringy material or chunks over 3 inches in size and shall not contain, in the judgment of the Engineer, an excess of fine particles. Submit sample for the Engineer's approval.

## 2.7 WATER

- A. The Contractor shall be responsible to furnish his own supply of water to the site at no extra cost. If possible, the Owner shall furnish the Contractor upon request with an adequate source and supply of water at no charge. However, if the Owner's water supply is not available or not functioning, the Contractor shall be responsible to furnish adequate supplies at his own cost. All work injured or damaged due to the lack of water, or the use of too much water, shall be the Contractor's responsibility to correct. Water shall be free from impurities injurious to vegetation.

## 2.8 ANTIDESICCANTS

- A. Antidesiccants shall be emulsions or other materials which will provide a protective film over plant surfaces to permit transpiration and specifically manufactured for that purpose. Manufacturer of antidesiccant shall be subject to the Engineer's approval and shall be used only after approval by the Engineer. Antidesiccant shall be delivered in containers of the manufacturer and shall be mixed and applied according to the manufacturer's instructions.

## PART 3 -EXECUTION

### PLANTING 02950-6

### 3.1 PLANTING

- A. Furnishing and planting of plant material shall include, but shall not be limited to, the digging of planting pits and plant beds, amendment of loam as required to produce planting soil mix, provision of soil additives required to adjust for pH requirements of specific plants, furnishing the plants as specified as well as the labor of planting fertilizing, and maintenance.
- B. Prior to spreading of loam, subgrades shall have been tested to determine if they are too compact to drain water as specified, performed and paid for under the work of Division 2 Section, TOPSOIL, of this Specification.
- C. The Contractor shall locate plant material sources and ensure that plants are shipped in timely fashion for installation.
- D. Contractor shall locate all existing underground utilities that are within 10 feet of the proposed planting pits and notify the Landscape Architect of any conflicts prior to digging plant pits.
- E. Seasons for Planting:
  - 1. Spring: Deciduous materials - March 21 through May 1; Evergreen materials - April 15 through June 1.
  - 2. Fall: Deciduous materials - October 1 through December 1; Evergreen materials August 15 through October 15.
- F. Plant Material Inspection:
  - 1. At least one month prior to the expected planting date, the Contractor shall request that the Engineer provide a representative to select and tag stock to be planted under this Division 2 Section, PLANTING. The Contractor shall pay for the transportation, subsistence and overnight accommodations, if necessary, for the Engineer's representative during the period of time required to select and tag the plant material.
  - 2. The Contractor shall be responsible to certify the availability of quality plants in Specified sizes from his/her sources of supply prior to requesting that the Engineer Make plant source inspections. In the event plants at the inspection location are Found to be unavailable or insufficient size, the contractor shall be liable to reimburse the Owner for all costs of the Engineer's hourly services which are incurred during unproductive inspection trips.
  - 3. Unless specifically designated otherwise, a representative of the Contractor shall accompany the Engineer on all plant material selection field trips.
  - 4. All trees for the project shall be individually tagged for approval with the Engineer's seals, and no trees shall be accepted for delivery to the site without such seals. Representative samples only of shrubs and ground cover plants may be tagged or marked for approval as an "Approved Typical Sample" and shipped to the site. Any

#### PLANTING 02950-7



shrub or groundcover plant that arrives at the construction site that does not meet the Approved Typical Sample will be rejected by the Engineer.

5. Plants to be inspected shall be in locations and conditions that allow direct and unobscured inspection by the Engineer. Container grown or balled and burlapped shrubs shall be pulled from holding blocks by the nurseryman for scrutiny by the Engineer at no additional cost to the Owner. Harvested trees held in storage shall not have branches tied up. Harvested trees shall not have trunks obscured by burlap, cardboard trunk protection, or other devices that would otherwise obscure inspection. In the event that branches are tied up, trunks are obscured by burlap or cardboard trunk protection, or root flares hidden by burlap and twine and the Engineer cannot inspect root flares, trunks or branching habit, the Contractor shall bear all responsibility and costs associated with tree rejection at a later date during the course of the Contract.
  6. Inspection and approval of plants at the source shall not impair the right of subsequent inspection and rejection upon delivery to the site, or during the progress of the work if the Engineer finds that plants do not meet the requirements of the PLANT SCHEDULE or this Contract, have declined noticeably due to handling abuse, lack of maintenance, or other causes. Cost of replacements, as required, shall be borne by the Contractor.
- G. Placement of Loam for planting soil shall be specified under the work of Division 2 Section, TOPSOIL, of this Specification. Obtain Engineer's written approval of work of rough grading and finish grading prior to starting the work of planting.
- H. Planting:
1. Notify the Engineer three (3) working days prior to the proposed arrival of plant material on the site. If not planted within 24 hours of delivery to the site, all plants shall be maintained in an on-site nursery. Container grown shrubs stored on site shall be shaded from direct sunlight at all times and shall not be stored directly on paved surfaces. All plants delivered to the site and not planted within 24 hours of delivery shall have their root balls covered with mulch and shall be watered on a daily basis such that root balls are kept moist throughout.
  2. Locations for all plants and outlines for planting areas shall be staked on the ground by the Contractor for approval by the Engineer before any plant pits or plant beds are dug. Notify the Engineer no less than 3 days prior to desired inspection date of staking to schedule site visit.
  3. Circular plant pits shall not be required provided that the minimum dimension between the edge of the pit and the face of the rootball is not less than required by this Division 2 Section, PLANTING.
  4. All plant pits dug with a machine shall have the sides of the holes scraped with hand shovels to prevent glazing or compaction of the sides of the hole. Remove and stockpile excavated loam for reuse as backfill for plant pit. All subsoil excavated from the bottoms of planting pits shall be removed from the site.

PLANTING  
02950-8

5. Plant pits shall be dug to the dimensions shown on the Contract Documents.
  - a. Individual plant pits for shrubs shall be three times greater in diameter than the diameter of the root ball. Place root ball directly on subgrade. Slope sides of tree pits at a 45 degree angle.
  - b. Plant beds for shrub massing shall be one large and continuous excavated bed. Extend bed no less than 3 feet beyond limits of shrub root balls on perimeter of bed.
  - c. Plant pits for trees and shrubs shall be dug to the depth of the rootball to be planted.
  - d. Remove all soil from around the root flare of the stem of the plant and from the top of the rootball to determine the true depth of the rootball. All plants that have been planted and have root flares that are buried will be rejected.
6. All plant roots and earth balls must be damp and thoroughly protected from sun and wind from the beginning of the digging operation, during transportation, and at the site until the final planting.
7. Remove container plants from containers prior to planting.
8. Shrubs shall be placed in the center of plant pits, plumb, with the crown of their roots exposed and located above the surrounding finish grade.
9. Prior to completion of planting installations, remove rope and cut wire baskets from the top 1/3 of the root balls. Pull burlap away from the trunk or stem of the plant and cut burlap from the top 1/3 of the root balls.
10. Planting shall be backfilled with approved planting soil to the full depth of the planting pit or bed. Eliminate air pockets and compact the soil by flooding the tree pit or plant bed within 2 hours of planting installation. After water has drained from the planting pit or bed and planting backfill has dried enough additional planting soil shall be spread in pit or bed to bring the finished surface of the planting pit or bed to grades shown on the Contract Documents. A saucer shall be formed around each plant at a depth of 3 inches for trees and for shrubs.
11. Fertilizer shall be spread over the plant saucer or plant bed between the saucer and the rootball. Till the fertilizer into the soil to a depth of four inches prior to the placement of the planting mulch. Fertilizer shall be provided for under the Division 2 Section, TOPSOIL, of this Specification. Do not mulch until placement of the fertilizer

has been verified by the Engineer. Fertilizer application rates shall be as determined by soil testing, analysis, and testing laboratory recommendations specified.

- I. All plants shall be watered immediately following planting as necessary to thoroughly moisten rootball and plant pit loam and thereafter shall be inspected frequently for watering needs and watered, as required, to provide adequate moisture in the planting pit. The Contractor shall inspect tree pits 24 hours after initial watering to confirm that they are draining properly. If surface water or excessively saturated plant pit soils exist, the

## PLANTING 02950-9

Contractor shall immediately notify the Engineer. The Engineer will recommend remedial measures based upon site conditions.

- J. Mulch material shall be placed over entire saucer areas of individual trees and shrubs and over the entire area of planting beds to a depth of 3 inches after settlement, not later than one week after planting. Do not apply mulch prior to the first watering of plant materials. Do not apply mulch prior to placement of surface applied fertilizer and verification of placement by the Engineer.
- K. Pruning:
  - 1. As directed by the Engineer, each plant shall be pruned in accordance with the workmanship requirements of "Pruning Standards" for Class I, fine pruning, to preserve the natural character of the plant.
  - 2. Tree pruning, as required, shall be undertaken to the full height of affected trees.
  - 3. All dead wood or suckers and all broken or badly bruised branches shall be removed. Never cut a leader.
- L. Antidesiccant shall be applied to all evergreen and broadleaf evergreen plants in December and again in February, according to manufacturer's application recommendations and as directed by the Landscape Architect.
- M. Protect existing lawns from damage. Any damage resulting from planting operations shall be repaired immediately at no cost to the Owner. Repair work shall be as specified and installed under the work of Division 2 Section, LAWNS, of this Specification and paid for under this Division 2 Section, PLANTING.
- N. In the event that rock or underground construction work or obstructions are encountered in any plant pit or bed excavation work, alternate locations will be selected by the Landscape Architect. Relocation of plant pits or beds shall be provided at no additional cost to the Owner. Provide the Landscape Architect with no less than 48 hours notice of obstruction so that a site visit can be scheduled to establish new locations for plants.
- O. Absolutely no debris may be left on the site. Repair any damage to site as directed by the Landscape Architect, at no additional cost.

### 3.2 MAINTENANCE

- A. Maintenance shall begin immediately after each plant is planted and shall continue for a minimum 30-day Monitoring Period and until the end of the fall planting season following Final Acceptance.
- B. Maintenance shall consist of keeping the plants in a healthy growing condition and shall include but is not limited to watering, weeding, cultivating, pruning, re-mulching, straightening of trees to a plumb position, removal of dead material, resetting plants to proper grades or upright position, and maintaining the planting saucer.

## PLANTING 02950-10

1. Plants shall be inspected for watering needs at least twice each week and watered to promote plant growth and vitality. The following watering rates assume that the soil is free draining. If the on site conditions do not ensure a free draining soil, then notify the Engineer in writing of this condition. Watering rates for trees, shrubs, ground cover, vines and perennials in free draining soils are presented here as guidelines to ensure that the top six inches of plant bed soil remains moist at all times. Actual watering rates may vary depending upon soil conditions. Guideline rates shall be as follows:

<u>Type of Plant/Size</u>	<u>Weekly Watering Rate</u>
Shrubs	
Up to 2 ft. height	10 gallons
2 - 4 ft. height	20 gallons
4 - 6 ft. height	30 gallons
6 - 8 ft. height	40 gallons

- a. Water shall be applied by 1 inch diameter hose with an attached metering gauge.
2. For trees in mulched beds, apply water to the ground surface directly under the canopy. Water shall be applied at a sufficiently slow rate to prevent run off from the soil surface but great enough to equal 0.2 inches of water per square foot of canopy area per hour for 5 hours per week.
  3. Planting beds and individual plant pits shall be kept free of weeds, and mulch shall be replaced as required to maintain the specified layer of mulch. Beds and individual pits shall be neat in appearance and maintained to the designed layout.
  4. Plants that die during the maintenance period shall be removed and replaced by the Contractor within one week of notification and replaced during that growing season, unless directed otherwise by the Engineer.
  5. Work of pruning, fertilizing, spraying, and similar activities shall be undertaken only by Certified Arborists and licensed chemical applicators, as pertinent to the work performed.
- C. During the maintenance period, any decline in the condition of plantings shall require the Contractor to take immediate action to identify potential problems and undertake corrective measures. If required, the Contractor shall engage professional arborists and/or

horticulturalists to inspect plant materials and to identify problems and recommend corrective procedures. The Engineer shall be immediately advised of such actions. Inspection and recommendation reports shall be submitted to the Engineer.

### 3.3 ACCEPTANCE

- A. Upon completion of all planting work, the Contractor shall request in writing that the Engineer formally inspect the planting work.

### PLANTING 02950-11

- B. If plant materials and workmanship are acceptable, the Engineer will issue a written Certificate of Conditional Acceptance to the Contractor.
- C. Following the issuance of the Certificate of Conditional Acceptance to the Contractor, the Contractor shall maintain the plants for a minimum 30 day Monitoring Period. At the end of the Monitoring Period, the plant material will be inspected by the Engineer to determine whether or not all planting work has been performed to the requirements of this Division 2 Section, PLANTING.
- D. Acceptance Standards at end of the Monitoring Period: If plant material is reviewed when it is in full leaf, leaves shall be plump with water with a shape indicative of the species and shall be free of insect, pest and disease damage. Twigs shall have living cambium for their full length. Twigs and branches shall have a full bud set for their full length, including terminal buds. Trunks and branches shall be free of frost cracks; sun scald; damage due to insects, pests, and disease; structural defects; and damage resulting from machinery or tools. Plant material inspected and reviewed when the plants are not in full leaf shall have twigs, branches and trunks meeting the above requirements. All plants regardless of the season of review shall have a minimum of 75 percent healthy, balanced branching structure with a healthy terminal leader(s) with viable terminal bud(s).
- E. If any number of plants do not meet these Acceptance Standards at the time of inspection, or if in the Engineer's opinion, workmanship is unacceptable, written notice will be given by the Engineer to the Contractor in the form of a punch list, which itemizes necessary planting replacements and/or other deficiencies to be remedied. The Contractor's responsibility for maintenance of all plants shall be extended until replacements are made or other deficiencies are corrected. All plants that do not meet these Acceptance Standards shall be removed from the project within seven days of receipt of the punch list. Replacements shall conform in all respects to the Specifications for new plants and shall be planted in the same manner.
- F. Following the correction of all Punch List deficiencies, the Contractor shall request in writing that the Engineer formally inspect the planting work. If plant materials and workmanship are acceptable, the Engineer will issue a written Certificate of Final Acceptance to the Contractor.

### 3.4 GUARANTEE

- A. The date of the Certificate of Final Acceptance shall establish the commencement of the required one-year guarantee and establishment period for planting work.
- B. At the end of the guarantee and establishment period, a final inspection will be held to determine whether any plant material replacements are required. Each plant shall be plumb, shall have a character that is natural for its species as determined by the Engineer, and shall conform to the Acceptance Standards described in this Division 2 Section, PLANTING. Plants found to be unacceptable shall be removed promptly from the site and replaced according to this Division 2 Section, PLANTING. A final inspection will be made after the replacement plants have lived through one year.

## PLANTING 02950-12

- C. At the end of the one-year guarantee and establishment period, remove all tree stakes, guys, or anchors installed on trees during the course of the work of this contract.
- D. All replacements shall be plants of the same kind and size. The cost shall be borne by the Contractor, except for possible replacements due to vandalism or neglect on the part of others.

END OF SECTION 02950

## **Division 3 – Concrete**

## SECTION 03300

### CAST-IN-PLACE CONCRETE

#### PART 1-GENERAL

##### 1.1 SUMMARY

In general, the Contractor shall supply all labor, equipment, temporary protection, tools and appliances necessary for the proper completion of the work as required in the specifications and in accordance with good construction practice. Refer to the Contract Drawings for locations of work included in the contract.

A. Work Included - The work under this section generally includes the following:

1. Concrete building foundations
2. Concrete slabs
3. Exterior concrete stairs
4. Concrete retaining walls

##### 1.2 RELATED DOCUMENTS

A. Drawings and general provisions of the Contract, including General and Supplementary Conditions and other Division 1 Specification Sections, apply to this section, and:

1. Section 02200 Earthwork

##### 1.3 SUBMITTALS

A. In addition to Product Data, submit design mixes for each concrete mix.

##### 1.4 QUALITY ASSURANCE

A. Quality Assurance: Comply with ACI 301, "Specification for Structural Concrete," and ACI117, "Specifications for Tolerances for Concrete Construction and Materials."

1. Installer Qualifications: An experienced installer who has completed concrete Work similar in material, design, and extent to that indicated for this Project and whose work has resulted in construction with a record of successful in- service performance.
2. Manufacturer Qualifications: A firm experienced in manufacturing ready-Mixed concrete products complying with ASTM C 94 requirements for production facilities and equipment.

### CAST-IN-PLACE CONCRETE

03300-1



## PART 2-PRODUCTS

### 2.1 MATERIALS

#### A. Steel Reinforcement: As follows:

1. Reinforcing Bars: ASTM A 615/A 615M, Grade 60, deformed.
2. Plain-Steel Wire: ASTM A 82, as drawn.
3. Deformed-Steel Wire: ASTM A 496.
4. Plain-Steel Welded Wire Fabric: ASTM A 185, flat sheets.

#### B. Concrete Materials: As follows:

1. Portland Cement: ASTM C 150, Type I or II.
2. Aggregate: ASTM C 33, uniformly graded, from a single source.
3. Water: ASTM C 94.
4. Air-Entraining Admixture: ASTM C 260.
5. Water-Reducing Admixture: ASTM C 494, Type A.
6. High-Range, Water-Reducing Admixture: ASTM C 494, Type F.
7. Water-Reducing and Accelerating Admixture: ASTM C 494, Type
8. Water-Reducing and Retarding Admixture: ASTM C 494, Type D.

#### B. Related Materials: As follows:

1. Vapor Retarder: ASTM E 1745, Class C, not less than 7.8 mils polyethylene sheet.
2. Joint-Filler Strips: ASTM D 1751, asphalt-saturated cellulosic fiber, or ASTM D 1752, cork or self-expanding cork.
3. Bonding Agent: ASTM C 1059, Type II, non-redispersible, acrylic emulsion or styrene butadiene.
4. Epoxy-Bonding Adhesive: ASTM C 881, two-component epoxy resin, of class and grade to suit requirements.

#### D. Curing Materials: As follows:

1. Evaporation Retarder: Waterborne, monomolecular film forming, manufactured for application to fresh concrete.
2. Absorptive Cover: AASHTO M 182, Class 2, burlap cloth made from jute or kenaf, weighing approximately 9 oz./sq. yd. dry.
3. Moisture-Retaining Cover: ASTM C 171, polyethylene film or white burlap-polyethylene sheet.
4. Clear, Waterborne, Membrane-Forming Curing and Sealing Compound: ASTM C 1315, Type 1, Class A.
  - a. 2 coats Sonneborn "Kure-N-Seal" or equal.

### 2.2 CONCRETE MIXES

#### A. Concrete Mixes, General; - Prepare design mixes, proportioned according to ACI 211.1 and ACI 301, with the following properties:

#### CAST-IN-PLACE CONCRETE 03300-2

- B. Footings, Foundations, Retaining Walls
  - 1. Compressive Strength (28 Days): 3000 psi.
  - 2. Slump: 4 inches.
  - 3. Air Content: 4.5 to 7.0 percent.
- C. Slabs
  - 1. Compressive Strength (28 Days): 4000 psi.
  - 2. Slump: 3 inches.
  - 3. Air Content: 4.5 to 7.0 percent
- D. Ready-Mixed Concrete: Measure, batch, mix, and deliver concrete according to ASTM C 94 and ASTM C 1116, and furnish batch ticket information.

## PART 3 EXECUTION

### 3.1 FORMWORK

- A. Design, construct, erect, shore, brace, and maintain formwork, according to ACI 301, to support vertical, lateral, static, and dynamic loads, and construction loads that might be applied, until concrete structure can support such loads.
- B. Place and secure anchorage devices and other embedded items required for adjoining work that is attached to or supported by cast-in-place concrete. Use Setting Drawings, templates, diagrams, instructions, and directions furnished with items to be embedded.
- C. Leave formwork, for beam soffits, joists, slabs, and other structural elements, that supports weight of concrete in place until concrete has achieved 28-day design compressive strength.
- D. Comply with ACI 318, ACI 301, and recommendations in ACI 347R for design, installation, and removal of shoring and reshoring.
- E. Vapor Retarder: Place, protect, and repair vapor-retarder sheets according to ASTM E 1643.

### 3.2 PLACING REINFORCEMENT

- A. Steel Reinforcement: Comply with CRSI's "Manual of Standard Practice" for fabricating, placing, and supporting reinforcement
  - 1. Do not cut or puncture vapor retarder. Repair damage and reseal vapor retarder before placing concrete.

### 3.3 JOINTS

- A. Locate and install construction, isolation, and contraction joints as indicated.

## CAST-IN-PLACE CONCRETE 03300-3

### 3.4 CONCRETE PLACEMENT

- A. Deposit concrete continuously and avoid segregation. Deposit concrete in forms in horizontal layers no deeper than 24 inches, avoiding cold joints.
  - 1. Consolidate concrete with mechanical vibrating equipment.
  - 2. Screed and initial-float concrete floors and slabs using bull floats or darbies to form a uniform and open-textured surface plane, free of humps or hollows, before excess moisture or bleedwater appears on the surface. Do not further disturb slab surfaces before starting finishing operations.
  - 3. Comply with ACI 306.1 for cold-weather concrete placement.
  - 4. Place concrete according to recommendations in ACI 305R when hot-weather conditions exist.

### 3.5 FINISHING

- A. Finish formed surfaces as follows:
  - 1. Apply rough-formed finish, defined in ACI 301, to concrete surfaces indicated or not exposed to public view.
- B. Finishing Floors and Slabs: Comply with recommendations in ACI 302.1R for screeding, restraightening, and finishing operations for concrete surfaces.
  - 1. Float Finish: Apply float finish, defined in ACI 301, to surfaces indicated, to surfaces to receive trowel finish,
  - 2. Trowel Finish: Apply a trowel finish to surfaces indicated and to surfaces exposed to view or to be covered with resilient flooring, carpet, ceramic or quarry tile set over a cleavage membrane, paint, or another thin film-finish coating system.
    - a. After applying float finish, apply first trowel finish and consolidate concrete by hand or power-driven trowel. Continue troweling passes and restraighten until surface is free of trowel marks and uniform in texture and appearance. Grind smooth any surface defects that would telegraph through applied coatings or floor coverings.
    - b. Finish and measure surface so gap at any point between concrete surface and an unlevelled freestanding 10-foot long straightedge, resting on two high spots and placed anywhere on the surface, does not exceed the following: 1/8 inch.
  - 3. Trowel and Fine-Broom Finish: Apply a partial trowel finish, stopping second troweling, to surfaces indicated and to surfaces where ceramic or quarry tile is to be installed by either thickset or thin-set method. Immediately after second troweling, and when concrete is still plastic, slightly scarify surface with a fine broom.

#### CAST-IN-PLACE CONCRETE 03300-4

4. Broom Finish: Apply a broom finish to exterior concrete, brooming with fiber-bristle broom perpendicular to main traffic route, to platforms, steps, and ramps, and elsewhere as indicated.

### 3.6 CONCRETE PROTECTION AND CURING

- A. Concrete Protection and Curing: Protect concrete from excessive cold or hot temperatures. Comply with ACI 306.1 for cold-weather protection and with recommendations in ACI 305R for hot-weather protection during curing.
  1. Apply evaporation retarder to unformed concrete surfaces if hot, dry, or windy conditions cause excessive moisture loss.
  2. Begin curing after finishing concrete but not before free water has disappeared from concrete surface.
  3. Cure formed and unformed concrete for at least seven days by moisture curing, moisture-retaining-cover curing, or curing compound.
  4. Cure and seal floors and slabs with a curing and sealing compound according to manufacturer's written instructions.

### 3.7 QUALITY CONTROL

- A. Testing Agency: The Contractor will engage a qualified independent testing and inspecting agency subject to Owner approval to sample materials, perform tests, and submit test reports during concrete placement. Tests shall be performed according to ACI 301.
- B. Defective Concrete: Repair and patch defective areas when approved by Engineer. Remove and replace concrete that cannot be repaired and patched to Engineer's approval.

END OF SECTION 03300

CAST-IN-PLACE CONCRETE  
03300-5

## SECTION 03600

### GROUT

#### PART 1-GENERAL

##### 1.1 SUMMARY

- A. Furnish all labor, materials, equipment and incidentals required to install grout for modifications to existing foundations, walls and manholes as shown on the Drawings and as specified herein.

##### 1.2 RELATEDWORK

- A. Cast-in-Place Concrete is included in Section 03300.

##### 1.3 SUBMITTALS

- A. Submit, in accordance with Section 01300, shop drawings and product data showing materials of construction and details of installer for:
  - 1. Commercially manufactured nonshrink cementitious grout. The submittal shall include catalog cuts, technical data, storage requirements, product life, working time after mixing, temperature considerations, conformity to required ASTM standards and Material Safety Data Sheet.
- B. Submit to Engineer, in accordance with Section 01300, proposed method of repairing penetrations of existing foundations (all types), including formwork arrangement and grout installation.

##### 1.4 REFERENCE STANDARDS

- A. American Society for Testing and Materials (ASTM)
  - 1. ASTM C531 - Standard Test Method for Linear Shrinkage and Coefficient of Thermal Expansion of Chemical Resistant Mortars, Grouts and Monolithic Surfacing and Polymer Concretes.
  - 2. ASTM C579- Standard Test Methods for Compressive Strength of Chemical-Resistant Mortars, Grouts and Monolithic Surfacing and Polymer Concretes.
  - 3. ASTM C827 - Standard Test Method for Change in Height at Early Ages of Cylindrical Specimens for Cementitious Mixtures.
  - 4. ASTM C1107- Standard Specification for Packaged D1y, Hydraulic-Cement Grout
- B. U.S. Army Corps of Engineers (CRD)

GROUT  
03600-1

1. CRD C-621 - Corps of Engineers Specification for Nonshrink Grout.
- C. Where reference is made to one of the above standards, the revision in effect at the time of the bid opening shall apply.

#### 1.5 DELIVERY, STORAGE AND HANDLING

- A. Deliver materials to the jobsite in original, unopened packages, clearly labeled with the manufacturer's name, product identification, batch numbers and printed instructions.
- B. Store materials in full compliance with the manufacturer's recommendations. Total storage time from date of manufacture to date of installation shall be limited to 6 months or the manufacturer's recommended storage time, whichever is less.
- C. Material which becomes damp or otherwise unacceptable shall be immediately removed from the site and replaced with acceptable material at no additional expense to the Owner.

### PART 2- PRODUCTS

#### 2.1 GENERAL

- A. The use of a manufacturer's name and product or catalog number is for the purpose of establishing the standard of quality desired.
- B. Like materials shall be the product of one manufacturer or supplier in order to provide standardization of appearance.

#### 2.2 MATERIALS

- A. Nonshrink Cementitious Grout:
  1. Nonshrink cementitious grouts shall meet or exceed the requirements of ASTM C1107, Grades B or C and CRD C-621. Grouts shall be Portland cement based, contain a pre-proportioned blend of select aggregates and shrinkage compensating agents and shall require only the addition of water. Nonshrink cementitious grouts shall not contain expansive cement or metallic particles. The grouts shall exhibit no shrinkage when tested in conformity with ASTM C827.
    - a. General purpose nonshrink cementitious grout shall conform to the standards stated above and shall be SikaGrout 212 by Sika Corp.; Set Grout by master Builders, Inc.; Gilco Construction Grout by Gifford Hill & Co.; Euco NS by The Euclid Chemical Co. NBEC Grout by U.S. Grout Corp. or equal.

GROUT  
03600-2

- b. Flowable (Precision) nonshrink cementitious grout shall conform to the standards stated above and shall be Masterflow 928 by Master Builders, Inc.; Hi-Flow Grout by the Euclid Chemical Co.; SikaGrout 212 by Sika Cotp.; Supreme Grout by Gifford Hill & Co.; Five Star Grout by U.S. Grout Corp. or equal.

B. Water:

- 1. Potable water, free from injurious amounts of oil, acid, alkali, organic matter or other deleterious substances.

## PART 3 EXECUTION

### 3.1 PREPARATION

- A. Surfaces to receive grout shall be clean and sound; free of ice, frost ice, dirt, grease, oil, curing compounds, laitance and paints and free of all loose material or foreign matter which may affect the bond or performance of the grout.
- B. Roughen concrete surfaces by chipping, sandblasting, or other mechanical means to ensure bond of the grout to the concrete. Remove loose or broken concrete. Irregular voids or projecting coarse aggregate need not be removed if they are sound, free of lattice and firmly embedded into the parent concrete.
  - 1. Air compressors used to clean surfaces in contact with the grout shall be the oilless type or equipped with an oil trap in the airline to prevent oil from being blown onto the surface.
- C. Construct grout forms or other leakproof containment as required. Forms shall be lined or coated with release agents recommended by the manufacturer. Forms shall be of adequate strength, securely anchored in place and shored to resist the forces imposed by the grout and its placement.

### 3.2 INSTALLATION- GENERAL

- A. Mix, apply and cure products in strict compliance with the manufacturer's recommendations and this section.
- B. Have sufficient manpower and equipment available for rapid and continuous mixing and placing. Keep all necessary tools and materials ready and close at hand.
- C. Maintain temperatures of the grout between 60 and 90 degrees F during grouting and until the grout compressive strength reaches 1000 psi or as recommended by the grout manufacturer, whichever is longer. Take precautions to minimize differential heating or cooling of existing surfaces and grout during the curing period.
- D. Take special precautions for hot weather or cold weather grouting as recommended by the manufacturer when ambient temperatures and/or the temperature of the materials in contact with the grout are outside of the 60 and 90 degrees F range.

GROUT  
03600-3

### 3.3 INSTALLATION- NONSHRINK CEMENTITIOUS GROUT

- A. Mix in accordance with the manufacturer's recommendations. Do not add cement, sand, pea gravel or admixtures.
- B. When mixing, add premeasured amount of water for mixing, followed by the grout. Begin with the minimum amount of water recommended by the manufacturer and then add the minimum additional water required to obtain the workability. Do not exceed the manufacturer's maximum recommended water content.
- C. Placements greater than 3-inches in depth shall include the addition of clean, washed pea-gravel to the grout mix when approved by the manufacturer. Comply with the manufacturer's recommendations for the size and amount of aggregate to be added.
- D. Place grout into the designated areas in a manner which will avoid segregation or entrapment of air. Do not vibrate grout to release air or to consolidate the material. Placement shall proceed in a manner which will ensure the filling of all spaces and provide full contact between the grout and adjoining surfaces. Provide grout holes as necessary.
- E. Place grout rapidly and continuously to avoid cold joints. Do not place cement grouts in layers. Do not add additional water to mix (retemper) after initial stiffening.
- F. Finish this surface with a wood float (brush) finish.
- G. Begin curing immediately after form removal and finishing. Keep grout moist and within its recommended placement temperature range for at least 24 hours after placement or longer if recommended by the manufacturer. Saturate the grout surface by use of wet burlap, soaker hoses, ponding or other approved means. Provide sunshades as necessary. If drying winds inhibit the ability of a given curing method to keep grout moist, erect wind breaks until wind is no longer a problem or curing is finished.

END OF SECTION 03600

GROUT  
03600-4



## **Division 14 – Mechanical**

## SECTION 15400

### PLUMBING- GENERAL PROVISIONS

#### PART 1 GENERAL

##### 1.1 SUMMARY

- A. Furnish all labor, materials, equipment, services and incidentals required and install and test new plumbing systems for redirecting private inflow sources from existing sump pumps as specified in the following:
  - 1. 15405 - Demolition (Interior Plumbing Systems)
  - 2. 15410 - Plumbing-Piping Systems
- B. More specifically the work shall include, but shall not be limited to the following:
  - 1. Installation of all plumbing piping and appurtenances to redirect sump pumps from the sanitary sewer system to either the storm drain system or a leaching basin.
  - 2. Disconnecting existing sump pump connections to the sanitary system.
  - 3. Cutting, coring and rough patching for penetrations through existing foundations and walls in accordance with Section 01045.
  - 4. Removal of existing piping in existing buildings. Refer to Section 15405 Demolition.
  - 5. The absence of all pipe supports and details on the Drawings shall not relieve the Contractor of the responsibility for providing them.

##### 1.2 RELATED WORK

- A. The following work related to, but not covered under the plumbing work will be done under other related Sections.
  - 1. Excavating and backfilling is included under Division 2.
  - 2. Concrete and grout is included under Division 3.

##### 1.3 SUBMITTALS

- A. Inspection by the Engineer of failure to inspect shall not relieve the Contractor of responsibility to provide materials and perform the work in accordance with the documents.

### PLUMBING-GENERAL PROVISIONS

15400-1

- B. Submit in accordance with Section 01300, shop drawings and product data to establish compliance with this Section. Submittals shall include the following:
  - 1. Shop drawings and technical literature covering details of piping and accessories being furnished under this section prior to fabrication, assembly or shipment.
  - 2. All submittals shall contain a statement that Section 15400 and all other referenced Sections have been read and complied with. The certification statement shall be made by all of the following that are applicable; the Contractor, sub-contractor and the vendor. The statement shall be an individual statement for each party involved, and shall be included with every submittal and resubmittal.
- A. Following completion of construction and acceptance, Contractor shall submit Detailed layout drawings of completed piping to Owner. Drawing shall show the locations of piping appurtenances and specialties.

#### 1.4 REFERENCE STANDARDS

- A. American Society for Testing and Materials (ASTM)
- B. American National Standards Institute (ANSI)
- C. American Water Works Association (AWWA)
- D. National Fire Protection Association (NFPA)
- E. National Electrical Manufacturers Association (NEMA)
- F. Plumbing and Drainage Institute (PDI)
- G. Cast Iron Soil Pipe Institute (CISP)
- H. Underwriters Laboratories (UL)
- I. Factory Mutual (FM)
- J. American Society of Plumbing Engineers Date Book (May be used as a design guide)
- K. Where reference is made to one of the above standards, the revision in effect at the time of bid opening shall apply.
- 1. Installer Qualifications: An experienced installer who has completed concrete Work similar in material, design, and extent to that indicated for this Project and whose work has resulted in construction with a record of successful in- service performance.

### PLUMBING-GENERAL PROVISIONS

15400-2

2. Manufacturer Qualifications: A firm experienced in manufacturing ready- mixed concrete products complying with ASTM C 94 requirements for production facilities and equipment.

## 1.5 QUALITY ASSURANCE

- A. The Contractor shall be fully responsible for the proper execution and performance of the work described herein. It shall be their responsibility to inspect all installation conditions and bring to the attention of the Owner any conditions which may affect their work adversely. They shall report to the Owner, prior to commencing and portion of this work, any conditions unsuitable for the installation of their portion of the work.
- B. Mention herein or indication on the Drawings of equipment, materials, operation or methods shall require that each item mentioned or indicated be provided to make a complete system of plumbing ready for continuous operation.
- C. The location of all fixtures and piping shall be considered as approximate only. Before the work is installed, the position of such equipment and piping to meet structural conditions and to provide proper headroom clearance or for other sufficient causes and such changes shall be made without additional expense to the Owner.
- D. Comply with all the laws, ordinances, codes, rules and regulations of the State, local or other authorities having jurisdiction over any of the work specified herein including the Commonwealth of Massachusetts Fuel, Gas, and Plumbing Code.
- E. Obtain all required permits and pay all legal fees for the same and in general take complete charge and responsibility for all legal requirements pertaining to this Section of work. .
- F. Requirements set forth in this Section and indicated on the Drawings shall be followed when in excess of the required or minimum regulations.
- G. If any work is performed and subsequent changes are necessary to conform to the regulations, such change shall be made as part of this work at no additional cost to the Owner.
- H. All work shown on the Drawings is intended to be approximately correct to scale and to layout. The Drawings shall be taken in a sense as diagrammatic. Size of pipes and general method of running them are shown, but it is not intended to show every offset and fitting nor every structural difficulty that may be encountered. To carry out the true intent and purpose of the Drawings all necessary parts to make complete working systems ready for use shall be furnished without extra charge.
- I. Locations shown on the Drawings shall be checked and all measurements must be taken at the building.

## PLUMBING-GENERAL PROVISIONS

15400-3

## 1.6 SERVICE AND UTILITY CONNECTIONS

- A. The storm drainage systems for sump pumps shall terminate at the connection to the existing drain service outside the building. The existing drain service is generally located at the property line or the back of the existing sidewalk.

## 1.7 DELIVERY, STORAGE AND HANDLING

- A. Refer to requirements of Section 01601.
- B. All materials shall be inspected for size, quality and quantity against approved shop drawings upon delivery.

## 1.8 COORDINATION

- A. The Contractor shall assume full responsibility for coordination of the Plumbing systems, including; scheduling, and verification that all structures and piping are compatible.
- B. The Contractor shall start up each system and shall make all adjustments so that the system is placed in proper operating condition.

## 1.9 SUPPORTS

- A. All components shall be provided with lugs, brackets or field supplied devices to allow the components to be firmly attached to the structure. The lugs, brackets or field supplied devices shall be sized to withstand the seismic loads for the area and type of application.

## 1.10 SEISMIC RESTRAINTS

- A. Seismic restraints shall be provided for all plumbing systems including but not limited to all piping installed under Division 15.

## PART 2 PRODUCTS (NOT USED)

## PART 3 EXECUTION

### 3.1 INSTALLATION

- A. All the items specified in Section 15410 shall be installed according to the applicable manufacturer's recommendations, the details shown on the Drawings and as specified herein and in other related Sections.
- B. The Contractor shall not install materials until the Owner and Engineer have approved all submittals. If any materials are installed prior to approval of the submittals, it shall be at the Contractor's risk.
- C. All work shall be installed in accordance with the manufacturer's printed instructions and shall be rigid, plumb and true to line, with all parts in perfect working order. Maintain protective covers on all units until final cleanup time and at that time re- move covers and clean and polish all surfaces.

## PLUMBING-GENERAL PROVISIONS

15400-4

3.2 PROTECTION

- A. Materials shall be properly protected at all times and all pipe openings shall be temporarily closed so as to prevent obstruction and damage.

END OF SECTION 15400

## SECTION 15405

### PLUMBING - DEMOLITION

#### PART 1 GENERAL

##### 1.1 SUMMARY

- A. Provide all labor, materials, equipment and incidentals required and remove and dispose of interior plumbing piping for private inflow source removal work in the existing buildings as indicated on the Drawings and as specified herein.
- B. Provide all plumbing demolition work associated with the removal of plumbing piping from the existing facilities, including disconnecting and removing all piping to the existing sanitary plumbing system and to sump pumps.
- C. Maintain storm water and groundwater flow in existing sump pump systems.
- D. Contractor shall adequately brace piping to remain prior to cutting existing piping and demolition of piping.
- E. Test sump pump for operation prior to demolition of existing sump pump piping.

##### 1.2 RELATED WORK

- A. Cutting, coring and patching is included in Section.

#### PART 2 PRODUCTS (NOT USED)

#### PART 3 EXECUTION

##### 3.1 GENERAL

- A. In general, the work includes removal and disposal of plumbing piping including their hangers and supports. Existing sump pump connections to the sanitary system to be abandoned shall be capped or plugged at the existing sanitary service indicated to remain as shown on the Drawings. Sump pump piping to be re-directed to the storm drain system or leaching basin shall be prepared for connection of new piping. All piping that is to be abandoned shall be removed.

#### DEMOLITION AND REMOVAL

- A. Remove piping to be limits shown on the Drawings. In general pipes indicated to be removed shall be removed back to the source or nearest point of usage.
- B. Remove all brackets, stems, hangers, and other accessories for the pipes being removed.

### PLUMBING DEMOLITION

15405-1

- C. Test sump pumps to determine if sump pumps are operational prior to demolition of existing sump pump piping.

3.3 DISPOSITION OF MATERIALS AND EQUIPMENT

- A. All material removed under this Section shall become the property of the Contractor and shall be removed from the site and disposed of by the Contractor.

END OF SECTION 15405

PLUMBING DEMOLITION  
15405-2



## SECTION 15410

### PLUMBING - SUMP PUMP PIPING SYSTEMS

#### PART 1 GENERAL

##### 1.1 SUMMARY

- A. This Section specifies the basic Plumbing Systems of Piping and the materials of each system, including valves and appurtenances.
- B. Furnish all labor, materials, equipment, services and incidentals required and install complete interior Plumbing Piping systems as shown on the Drawings and as specified herein for private inflow removal work including new piping and valves for existing sump pumps.
- C. Furnishing and installing all pipe, fittings, valves, plugs, cleanouts, and hangers in conjunction with the sump pump work. Reuse existing sump pumps. Redirect the discharge from the sanitary sewer to an onsite infiltration basin or to a storm drain as shown on the Drawings.
- D. All piping shown on the Drawings is intended to be approximately correct to scale and layout. The Drawings shall be taken in a sense as diagrammatic. Size of piping is shown, but it is not the intent to show every offset or fitting, nor every hanger or support, or structural difficulty that may be encountered. To carry out the intent and purpose of the Drawings all necessary parts to make a complete working system ready for use shall be furnished without extra charge. All work shall be in compliance with State and local plumbing codes including the Commonwealth of Massachusetts Fuel, Gas, and Plumbing Code.

##### 1.2 RELATED WORK

Refer to Section 15400.

##### 1.3 SUBMITTALS

- A. Submit in accordance with sections 15400 and 01300, shop drawings and technical literature covering details of all plumbing piping systems being furnished under this Section prior to fabrication, assembly or shipment.
- B. All submittals shall contain a statement that Sections 15400 and 15410 and all other referenced Sections have been read and complied with. The certification statement shall be made by all of the following that are applicable; the Contractor, sub- contractor and the vendor. The statement shall be an individual statement for each party involved, and shall be included with every submittal and resubmittal.
- C. Layout drawings of the completed piping shall be provided to the Owner. Drawings shall show detailed locations of piping appurtenances, specialties, and all valves.

### PLUMBING-SUMP PUMP PIPING SYSTEMS

15410-1

- D. Provide manufacturers catalogs, literature, and engineering data on all hangers and supports. Load ratings, materials, and installation shall be in accordance with the recommendations of MSS SP-58 and MSS SP-69.

#### 1.4 REFERENCE STANDARDS

- A. Refer to Section 15400.

#### 1.5 SERVICE AND UTILITY CONNECTIONS

- A. Refer to Section 15400.

#### 1.6 QUALITY ASSURANCE

- A. Inspection by the Engineer of failure to inspect shall not relieve the Contractor of responsibility to provide materials and perform the work in accordance with the documents.

#### 1.7 DELIVERY, STORAGE AND HANDLING

- A. All materials shall be inspected for size, quality and quantity against approved shop drawings upon delivery.

#### 1.8 COORDINATION

- A. The Drawings indicate the extent and general arrangement of the systems. If any departures from the drawings or specifications are deemed necessary, details of such departures and the reasons therefore shall be submitted as soon as practical for review to Owner.
- B. The Contractor shall assume full responsibility for coordination of the Plumbing systems, including; scheduling, and verification that all structures and piping are compatible.
- C. The Contractor shall make every effort to coordinate the location of new piping for the work of this Contract with the property owner. The completed layout shall not interfere with property owner's future use needs of the basement as much as possible. Any disagreement between property owner and Contractor shall be decided by the Owner.

#### 1.9 SEISMIC RESTRAINTS

- A. Refer to Section 15400.

### PART 2 PRODUCTS (NOT USED)

#### 2.1 SUMP PUMP PIPING SYSTEM

- A. Pipe for sump pump discharges shall be manufactured from PVC compounds meeting ASTM D1784, Class 12454-B in accordance with ASTM D1785, PVC

### PLUMBING-SUMP PUMP PIPING SYSTEMS

15410-2

1120. The pipe shall be suitable for field cutting and solvent welding. Pipe shall be of the sizes as shown on the Drawings and shall be Schedule 40 unless otherwise shown.

- B. Fittings shall be the socket type for solvent welded joints conforming to ASTM D2467 or ASTM D2466 where Schedule 40 pipe is shown on the Drawings. Fittings shall be manufactured from PVC compound meeting ASTM D1784, Class 12454-B. Solvent cement shall be as specified in ASTM D2564.

## 2.2 BALL CHECK VALVES

- A. It is the intention of the Drawings and this Section to install a check valve at the bottom of all sump pump service risers and as shown on the Drawings. If design does not include connection directly at sump pump and new PVC piping from the sump pump to the ceiling, the Contractor shall install a new check valve and union, as detailed in the existing riser piping and provide all couplings and adapters required to connect to existing piping.
- B. All valves shall be certified as completely compatible for use with groundwater or storm water; compatibility shall apply to the material of the valve and internal components, including all seals, gaskets, O-rings and washers; solvents and primers used in valve joint make-up shall be specifically in conformance with the written instructions of the valve supplier.
- C. Valve ends shall be socket-type designed for solvent welding. The valve manufacturer shall provide specific recommendations for solvent and primer.
- D. Valve material shall be PVC, Type 1, Grade 1, per ASTM D1784 classification, made from unplasticized polymer, and generally suitable for service to 120 degrees F.
- E. O-rings, valve seats and stem seals shall be Teflon, or Teflon encapsulated elastomer. Alternative materials may not be substituted without complete documentation provided to the Engineer of service suitability.
- F. Gaskets shall be made from PTFE-bonded sheet material, GORE-TEX manufactured by W.L. Gore & Associates; AV Low-Torque gaskets by Asahi/America or equal.
- G. No factory or field coatings shall be applied to the valves.
- H. All valves shall have a non-shock service pressure rating of not less than 120 psig at 70 degrees F. All valves shall be given hydrostatic and pressure and leakage tests at the factory.
- I. Ball check valves shall be double-union style with socket ends, solid and completely spherical ball and capable of either horizontal or vertical mounting. Valves shall be the standard, catalogued products of Chemtrol, Asahi/America, Plast-O-Matic, Hayward, or equal.

## PLUMBING-SUMP PUMP PIPING SYSTEMS

15410-3

## 2.3 CLEANOUTS

- A. Cleanouts shall consist of solvent weld PVC Schedule 40 tee or wye fitting with PVC screw cleanout plug with square or hexagonal nuts. Cleanout adapter with plug may be used as approved by the Engineer. All cleanouts shall be of size shown on the Drawings.

## 2.4 HANGERS, SUPPORTS AND ANCHORS

- A. Piping support systems shall include restraints as required by the applicable building codes to withstand seismic loading.
- B. The absence of pipe supports and details on the drawings shall not relieve the contractor of the responsibility for providing them.
- C. The Contractor shall be responsible to provide a complete system of supports, expansion joints, and anchors.
- D. All hangers shall be of a type to permit vertical adjustment after installation.

## 2.5 PLUGS

- A. Plugs for connections between the drain lines to be redirected to the storm water system and the existing sanitary system shall be a permanent plug fully enclosing or capping the existing connection to the sanitary system manufactured specifically for the type of pipe being plugged. All plugs and work shall be in accordance with local and state codes and regulations.

## PART 3 EXECUTION

### 3.1 INSTALLATION

- A. Install all piping, valves, hangers and appurtenances as specified herein and in the referenced Sections above.
- B. The Contractor shall not install any materials until the Owner and Engineer have approved all submittals. If any materials are installed prior to approval of the submittals, it shall be at the Contractor's risk.
- C. The Contractor is responsible for the final design conforming and correlating all quantities and dimensions, selecting fabrication processes and techniques of construction, and performing the work in a safe and satisfactory manner.
- D. Valves
  - 1. Install valves in locations to be easily operated.
- E. PVC Solvent Weld Piping and Valves

## PLUMBING-SUMP PUMP PIPING SYSTEMS

15410-4

1. The installation of plastic pipe shall be strictly in accordance with the manufacturer's technical data and printed instructions. Pipe slopes shall be in accordance with local and State plumbing codes.
2. Joints for PVC pipe shall be solvent cemented. In making solvent cemented connections, clean dirt and moisture from pipe and fittings, bevel pipe ends slightly with emery cloth to remove any shoulder or burrs created by cutting of the pipe. Solvent cement joints shall be made in accordance with ASTM D2855. Primer shall be used whenever recommended by the pipe, fitting, or cement manufacturer and in all cases for joints on pipe systems 4-in in diameter or larger. Making solvent cement joints shall not be performed and the work shall stop when the temperature, measured in the shade, is 40 degrees F and falling.
3. Joints between PVC pipe and cast-iron soil pipe shall be made with approved mechanical compression joints designed for such use.
4. Installation of valves and fittings shall be in accordance with manufacturer's instructions. In making solvent cement connections, the solvent cement or primer shall not be spilled on valves. Any cement allowed to run from joints shall be cleaned from the pipe and fittings immediately.

F. Cleanouts

1. Install cleanouts as shown and in accordance with applicable code, at end of each branch drain and pressure sump pump discharge line where rainwater lines change direction, and at the bottom of every drop as a cleanout tee above floor.

G. Plugs

1. Permanently plug connections between the existing drain lines and the sanitary system to be redirected to the storm drain system. Plugs shall be installed per the manufacturer's instructions and shall be fully air and water tight.

3.2 FIELD TESTING

- A. Provide all connections for testing sump pumps and roof drain systems under this Section. Remove all debris resulting from testing. Use the water in an efficient and economical manner.
- B. Provide all apparatus and all other supplies or materials which may be necessary for testing the roof drain and sump pump systems and operating the apparatus during the period while tests of any kind are being made, or for carrying out the work of the Contract.
- C. All additional tests, methods or materials that may be required by the local ordinances and not specifically specified herein, shall be made as directed by the local inspection authority.
- D. Provide for all repeated tests as necessary to make systems tight as required. E. Test sump pump piping as follows:

PLUMBING-SUMP PUMP PIPING SYSTEMS

15410-5

1. Test sump pump for operation prior to demolishing existing sump pump piping. If sump pump does not operate, provide alternate means for completing sump pump discharge piping test for completed work.
2. Test for leakage of sump pump piping by continually pumping water through completed piping system via existing sump pump for a minimum of 15 minutes. Make visual inspection of interior and exterior piping for leakage. Immediately repair any leaking or damaged piping and retest.

### 3.3 CLEANING

- A. At the completion of the work, clean all piping included in this Section. Return property and site to pre-construction conditions.

### 3.4 ACCEPTANCE INSPECTION

- A. Schedule appointment with plumbing inspector for inspection and acceptance of completed plumbing system for sump pump piping.
- B. Schedule appointment as close to completion of work as possible.

END OF SECTION 15410

## PLUMBING-SUMP PUMP PIPING SYSTEMS

15410-6

## **Appendix “A” – Drawings**

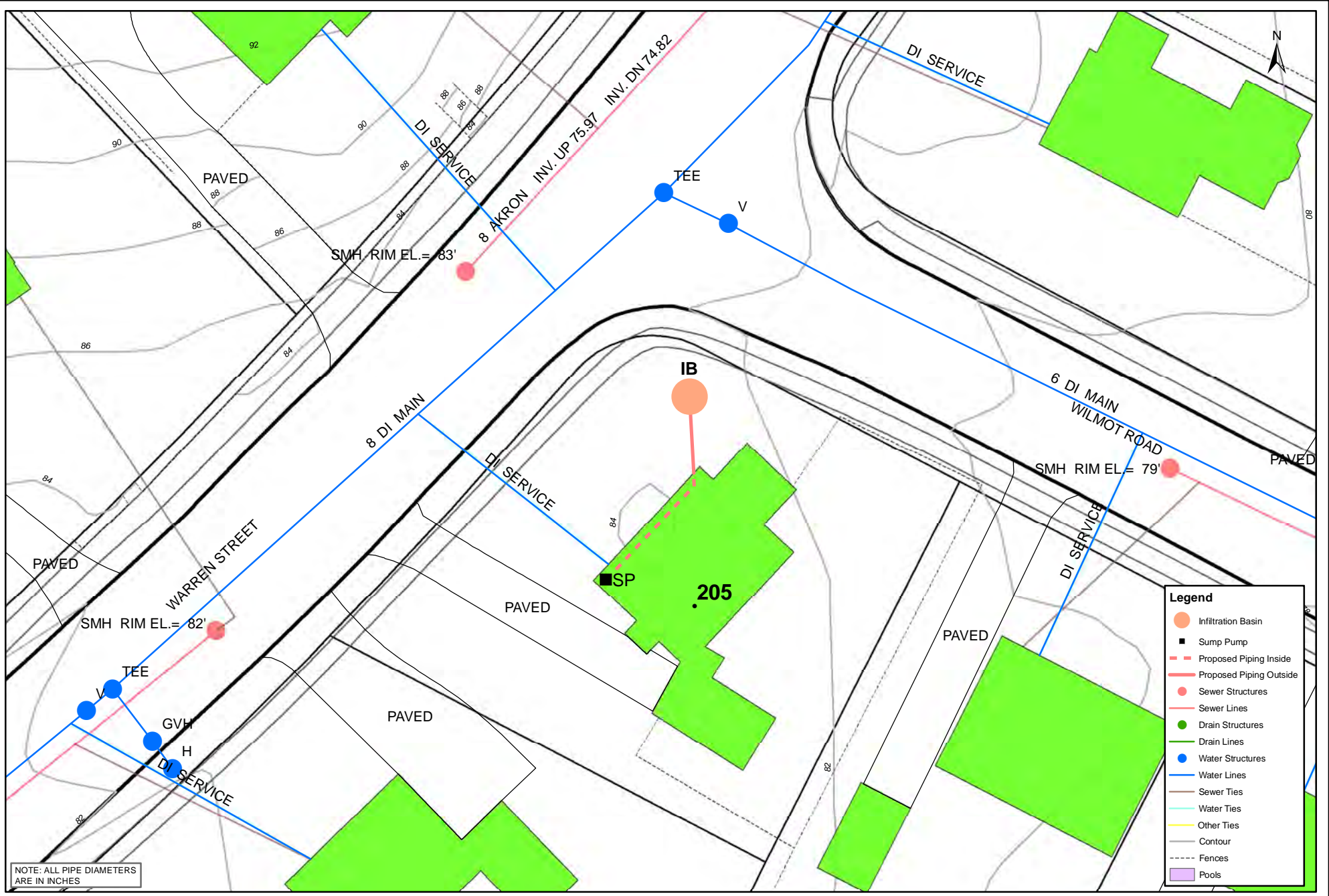

NOTE: ALL PIPE DIAMETERS ARE IN INCHES

**CITY OF WALTHAM - SUMP PUMP AMNESTY PROGRAM**  
**CONTRACT 2 - AREAS 5B, 5D & 15**  
**205 WARREN STREET**

1 inch = 25 feet

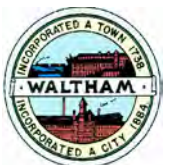



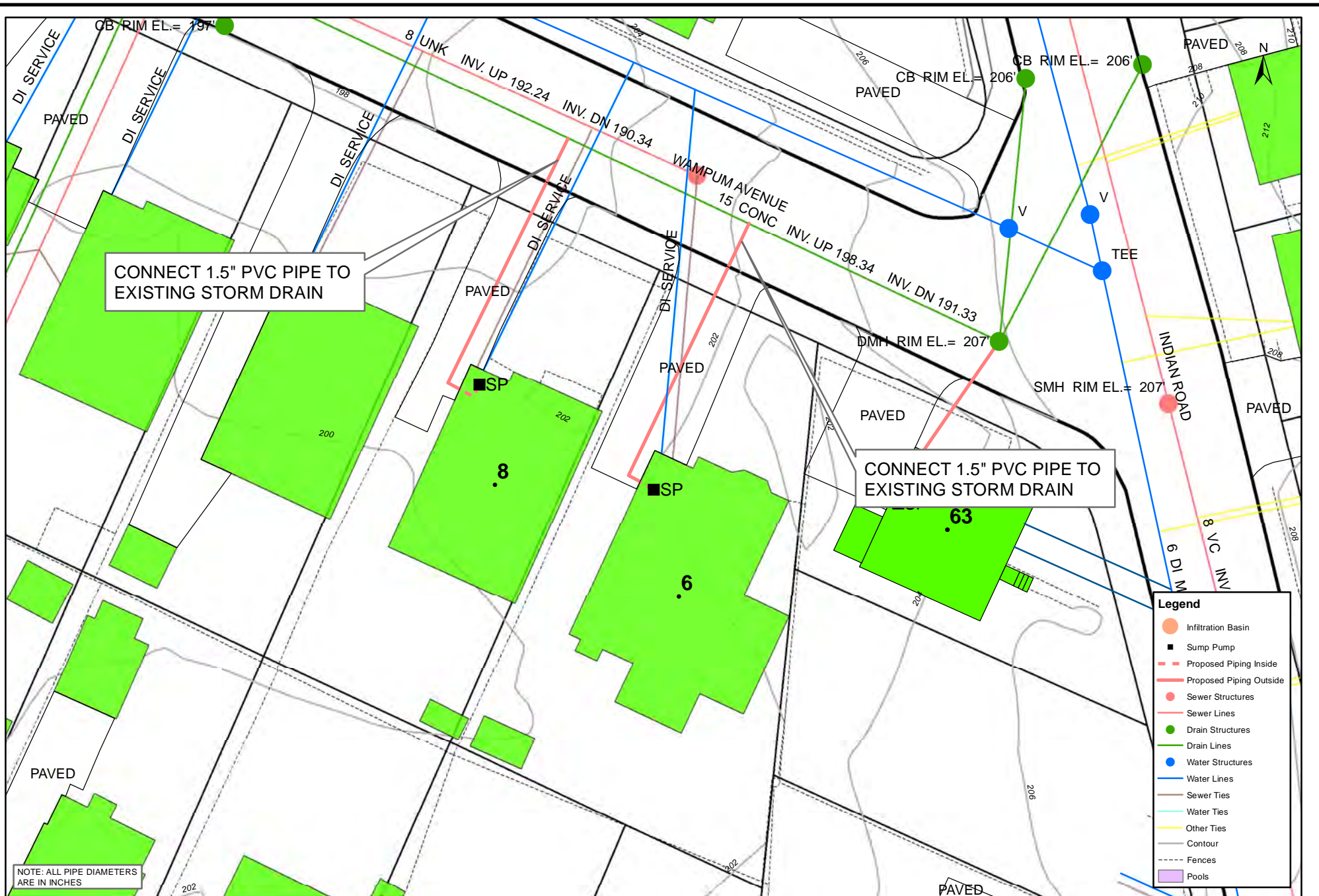

CONNECT 1.5" PVC PIPE TO EXISTING STORM DRAIN

CONNECT 1.5" PVC PIPE TO EXISTING STORM DRAIN

NOTE: ALL PIPE DIAMETERS ARE IN INCHES

Legend	
	Infiltration Basin
	Sump Pump
	Proposed Piping Inside
	Proposed Piping Outside
	Sewer Structures
	Sewer Lines
	Drain Structures
	Drain Lines
	Water Structures
	Water Lines
	Sewer Ties
	Water Ties
	Other Ties
	Contour
	Fences
	Pools



# CITY OF WALTHAM - SUMP PUMP AMNESTY PROGRAM

## CONTRACT 2 - AREAS 5B, 5D & 15

### 6 & 8 WAMPUM AVENUE

1 inch = 25 feet





**CITY OF WALTHAM - SUMP PUMP AMNESTY PROGRAM**  
**CONTRACT 2 - AREAS 5B, 5D & 15**  
**101 TRIMOUNT AVAENUE**

1 inch = 25 feet

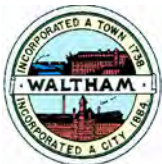



**CITY OF WALTHAM - SUMP PUMP AMNESTY PROGRAM**  
**CONTRACT 2 - AREAS 5B, 5D & 15**  
**88 TRIMOUNT AVAENUE**

1 inch = 25 feet

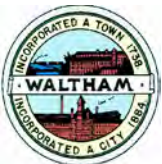



NOTE: ALL PIPE DIAMETERS ARE IN INCHES

Legend	
	Infiltration Basin
	Sump Pump
	Proposed Piping Inside
	Proposed Piping Outside
	Sewer Structures
	Sewer Lines
	Drain Structures
	Drain Lines
	Water Structures
	Water Lines
	Sewer Ties
	Water Ties
	Other Ties
	Contour
	Fences
	Pools

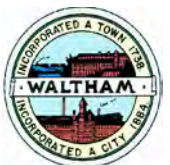

**CITY OF WALTHAM - SUMP PUMP AMNESTY PROGRAM**  
**CONTRACT 2 - AREAS 5B, 5D & 15**  
**71 STONE ROAD**

1 inch = 25 feet



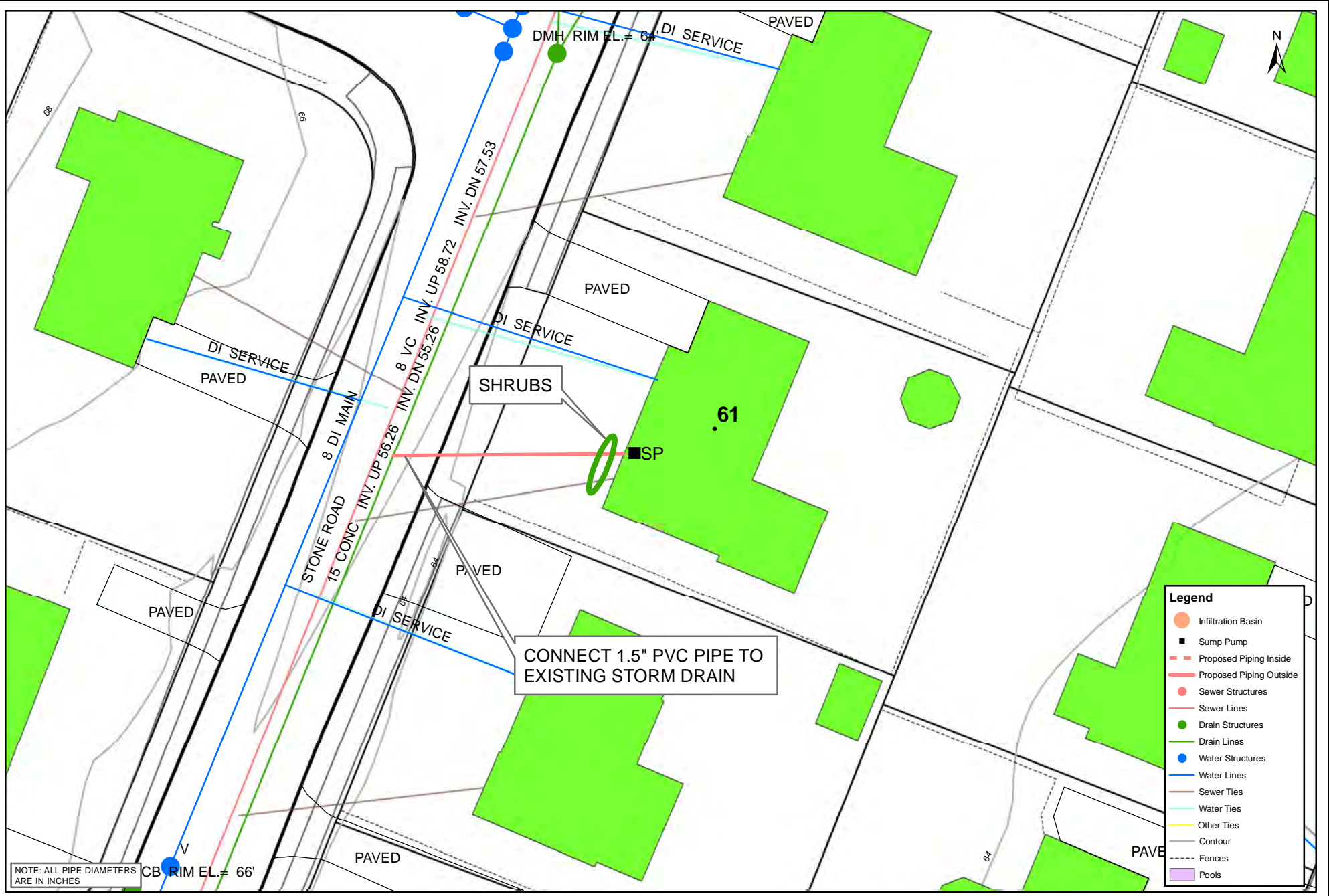

NOTE: ALL PIPE DIAMETERS ARE IN INCHES  
 CB RIM EL. = 66'

Legend	
	Infiltration Basin
	Sump Pump
	Proposed Piping Inside
	Proposed Piping Outside
	Sewer Structures
	Sewer Lines
	Drain Structures
	Drain Lines
	Water Structures
	Water Lines
	Sewer Ties
	Water Ties
	Other Ties
	Contour
	Fences
	Pools

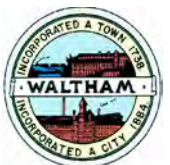

**CITY OF WALTHAM - SUMP PUMP AMNESTY PROGRAM**  
**CONTRACT 2 - AREAS 5B, 5D & 15**  
**61 STONE ROAD**

1 inch = 25 feet



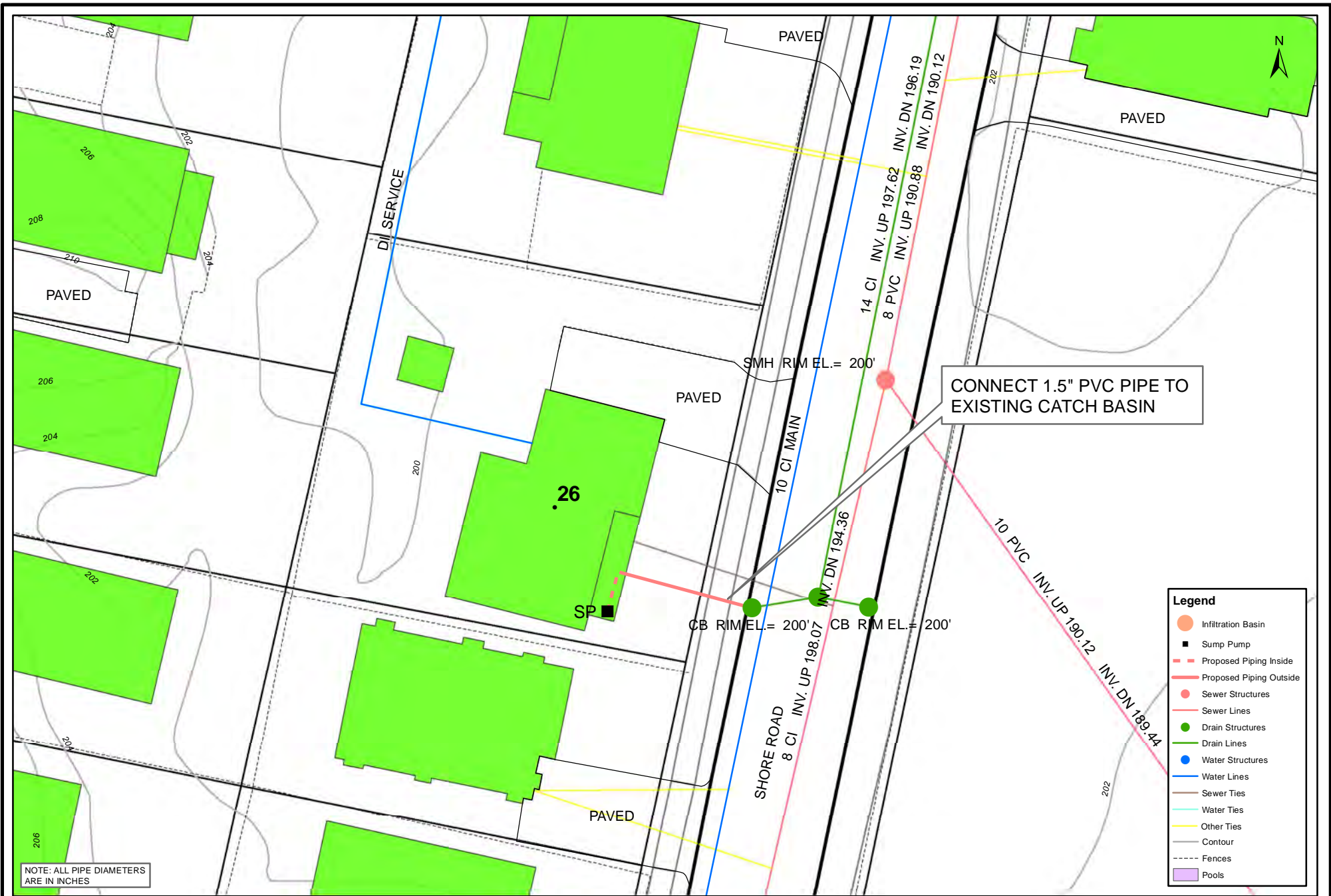

**CITY OF WALTHAM - SUMP PUMP AMNESTY PROGRAM**  
**CONTRACT 2 - AREAS 5B, 5D & 15**  
**26 SHORE ROAD**

1 inch = 25 feet

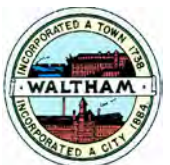



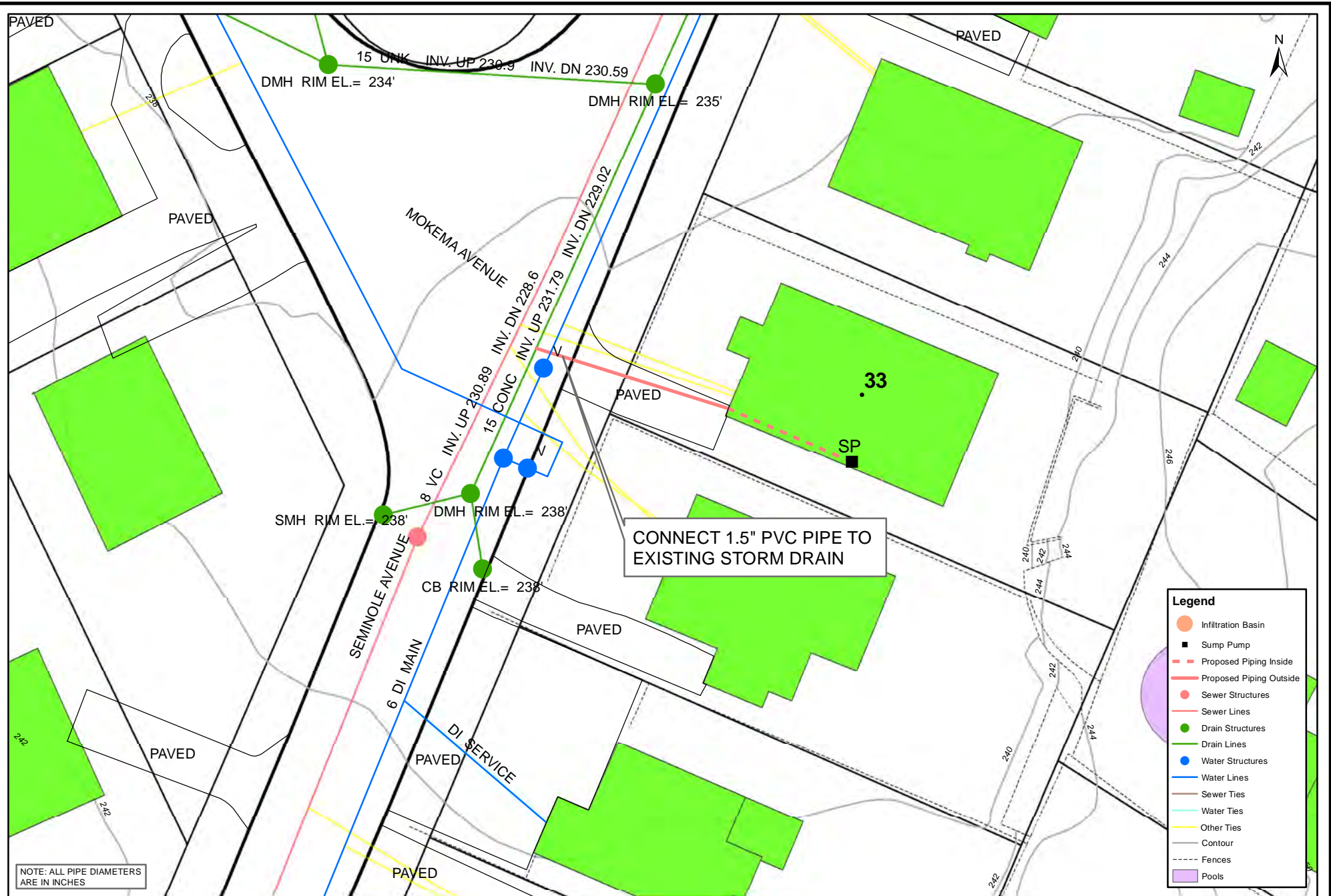

NOTE: ALL PIPE DIAMETERS ARE IN INCHES

Legend	
	Infiltration Basin
	Sump Pump
	Proposed Piping Inside
	Proposed Piping Outside
	Sewer Structures
	Drain Structures
	Drain Lines
	Water Structures
	Water Lines
	Sewer Ties
	Water Ties
	Other Ties
	Contour
	Fences
	Pools

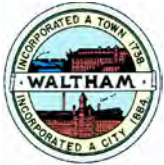

**CITY OF WALTHAM - SUMP PUMP AMNESTY PROGRAM**  
**CONTRACT 2 - AREAS 5B, 5D & 15**  
**33 SEMINOLE AVENUE**

1 inch = 25 feet







NOTE: ALL PIPE DIAMETERS ARE IN INCHES

**CITY OF WALTHAM - SUMP PUMP AMNESTY PROGRAM**  
**CONTRACT 2 - AREAS 5B, 5D & 15**  
**98, 104 & 105 PRINCETON AVENUE**

1 inch = 25 feet

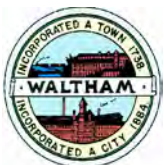



NOTE: ALL PIPE DIAMETERS ARE IN INCHES

**CITY OF WALTHAM - SUMP PUMP AMNESTY PROGRAM**  
**CONTRACT 2 - AREAS 5B, 5D & 15**  
**88 & 95 PRINCETON AVENUE**

1 inch = 25 feet

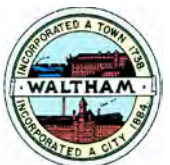



**CITY OF WALTHAM - SUMP PUMP AMNESTY PROGRAM**  
**CONTRACT 2 - AREAS 5B, 5D & 15**  
**43 OVERLOOK ROAD**

1 inch = 25 feet

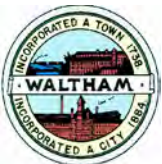



NOTE: ALL PIPE DIAMETERS ARE IN INCHES

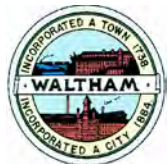

**CITY OF WALTHAM - SUMP PUMP AMNESTY PROGRAM**  
**CONTRACT 2 - AREAS 5B, 5D & 15**  
**11 NUTTING ROAD**

1 inch = 25 feet



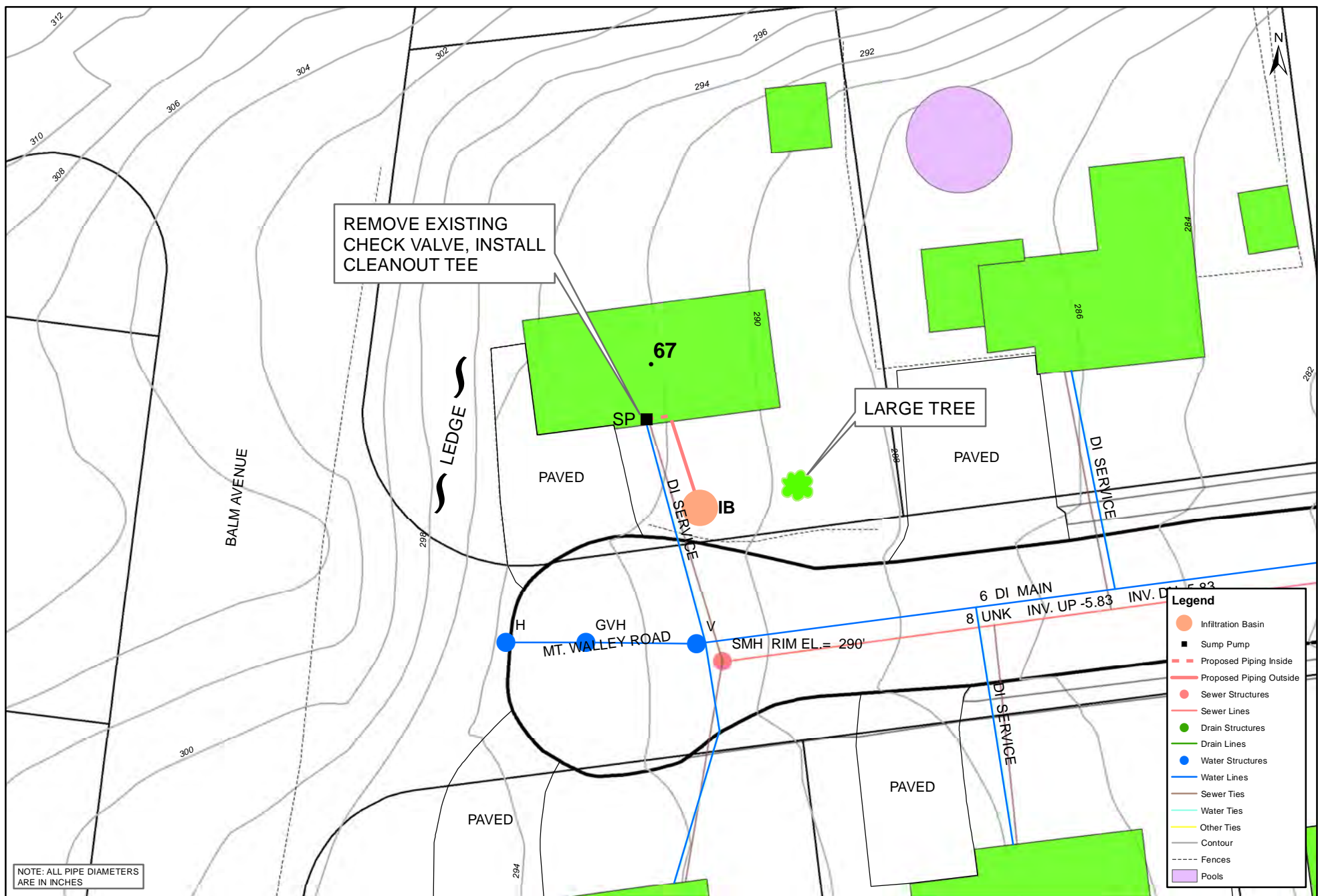

**CITY OF WALTHAM - SUMP PUMP AMNESTY PROGRAM**  
**CONTRACT 2 - AREAS 5B, 5D & 15**  
**67 MOUNT WALLEY ROAD**

1 inch = 25 feet

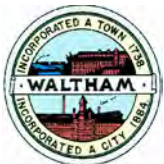

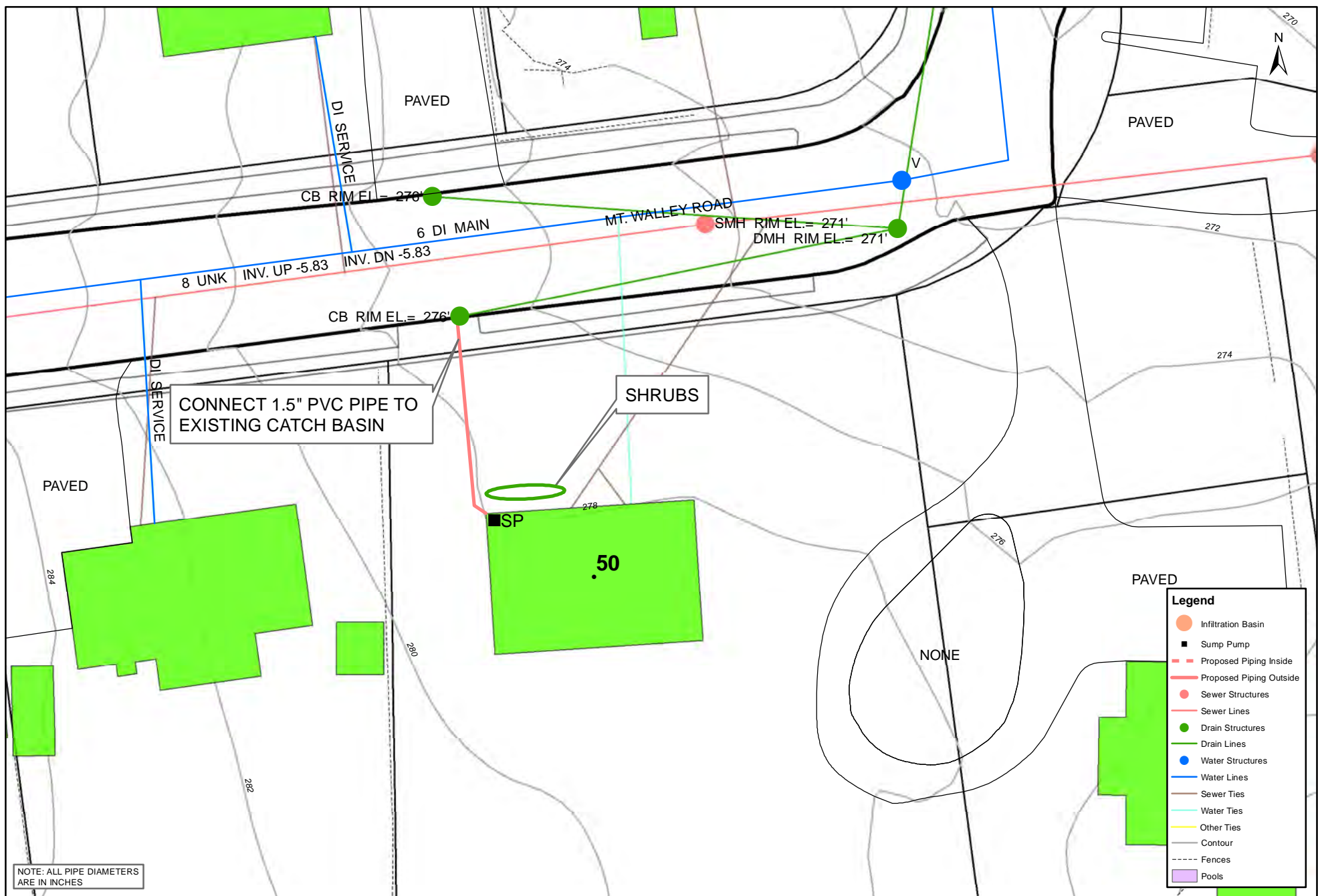

NOTE: ALL PIPE DIAMETERS ARE IN INCHES

Legend	
	Infiltration Basin
	Sump Pump
	Proposed Piping Inside
	Proposed Piping Outside
	Sewer Structures
	Drain Structures
	Drain Lines
	Water Structures
	Water Lines
	Sewer Ties
	Water Ties
	Other Ties
	Contour
	Fences
	Pools



# CITY OF WALTHAM - SUMP PUMP AMNESTY PROGRAM

## CONTRACT 2 - AREAS 5B, 5D & 15

### 50 MOUNT WALLEY ROAD

1 inch = 25 feet





Legend	
	Infiltration Basin
	Sump Pump
	Proposed Piping Inside
	Proposed Piping Outside
	Sewer Structures
	Sewer Lines
	Drain Structures
	Drain Lines
	Water Structures
	Water Lines
	Sewer Ties
	Water Ties
	Other Ties
	Contour
	Fences
	Pools

NOTE: ALL PIPE DIAMETERS ARE IN INCHES

**CITY OF WALTHAM - SUMP PUMP AMNESTY PROGRAM**  
**CONTRACT 2 - AREAS 5B, 5D & 15**  
**107 MOKEMA AVENUE**

1 inch = 25 feet

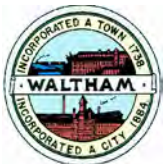



**CITY OF WALTHAM - SUMP PUMP AMNESTY PROGRAM**  
**CONTRACT 2 - AREAS 5B, 5D & 15**  
**47 MOKEMA AVENUE**

1 inch = 25 feet

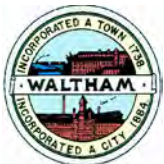



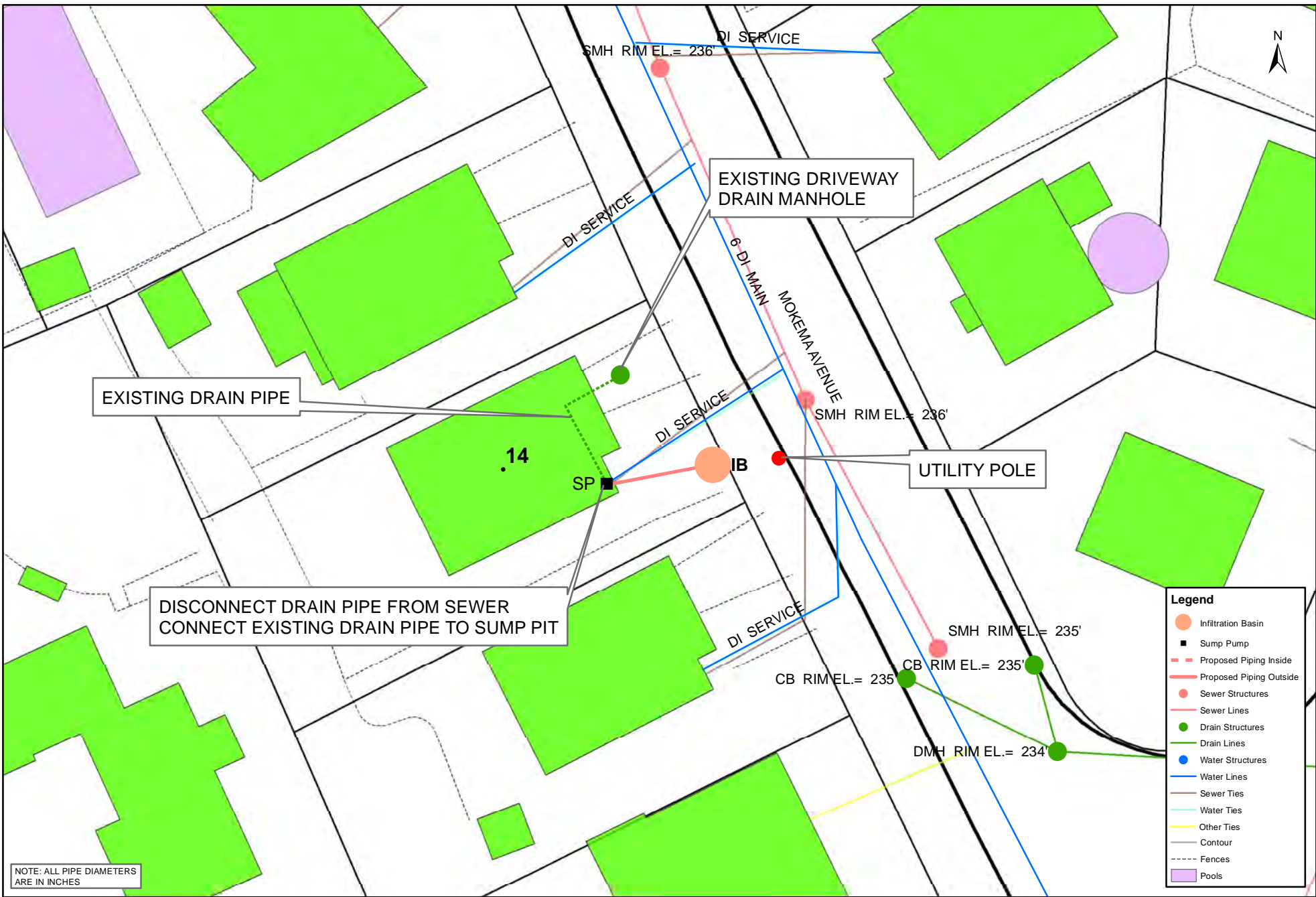

- Legend**
- Infiltration Basin
  - Sump Pump
  - Proposed Piping Inside
  - Proposed Piping Outside
  - Sewer Structures
  - Drain Structures
  - Drain Lines
  - Water Structures
  - Water Lines
  - Sewer Ties
  - Water Ties
  - Other Ties
  - Contour
  - - - Fences
  - Pools

NOTE: ALL PIPE DIAMETERS ARE IN INCHES

**CITY OF WALTHAM - SUMP PUMP AMNESTY PROGRAM**  
**CONTRACT 2 - AREAS 5B, 5D & 15**  
**14 MOKEMA AVAENUE**

1 inch = 25 feet

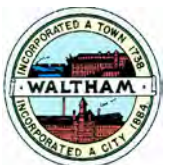

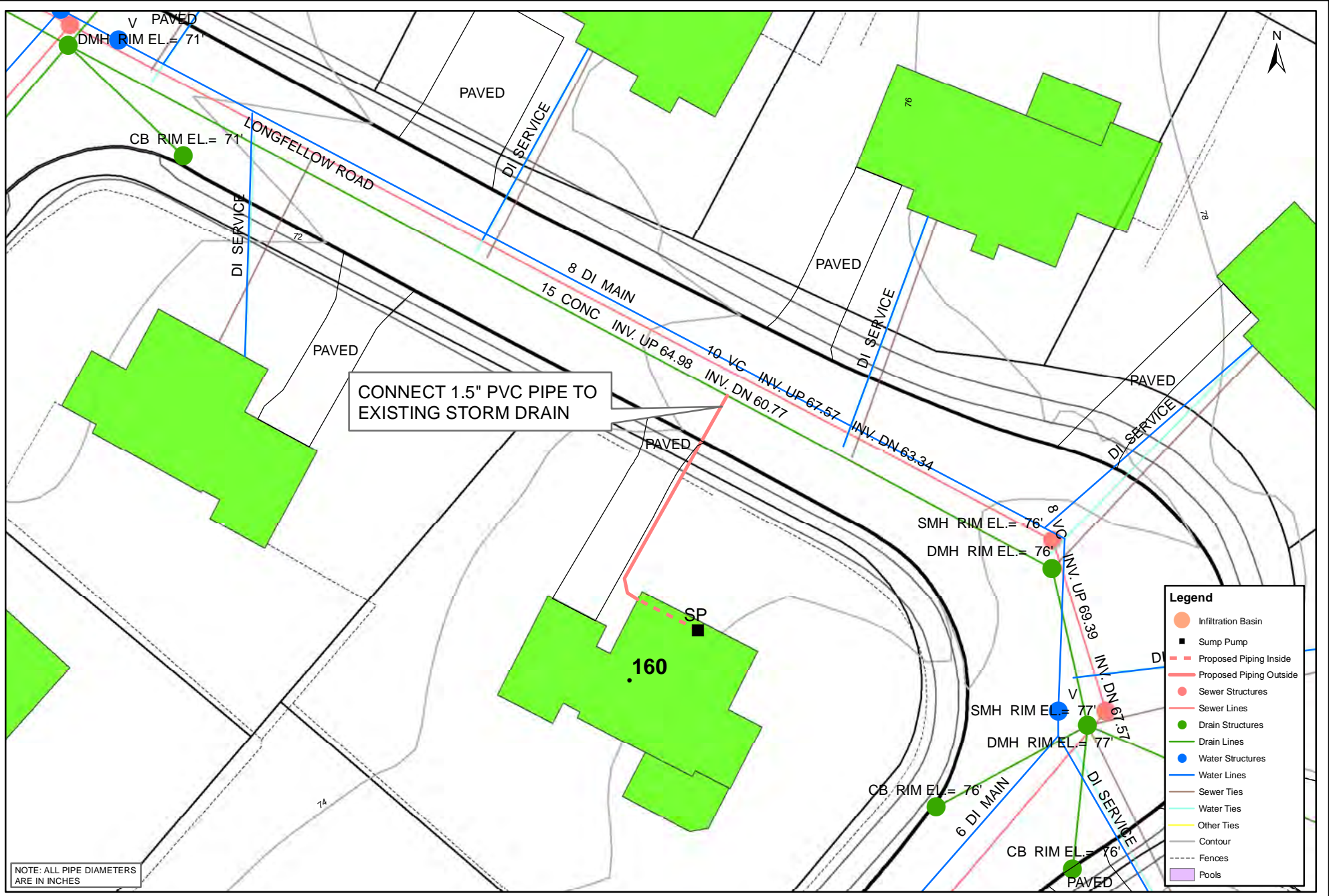

NOTE: ALL PIPE DIAMETERS ARE IN INCHES

Legend	
	Infiltration Basin
	Sump Pump
	Proposed Piping Inside
	Proposed Piping Outside
	Sewer Structures
	Sewer Lines
	Drain Structures
	Drain Lines
	Water Structures
	Water Lines
	Sewer Ties
	Water Ties
	Other Ties
	Contour
	Fences
	Pools

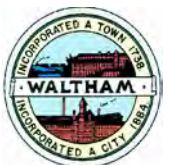

**CITY OF WALTHAM - SUMP PUMP AMNESTY PROGRAM**  
**CONTRACT 2 - AREAS 5B, 5D & 15**  
**160 LONGFELLOW ROAD**

1 inch = 25 feet



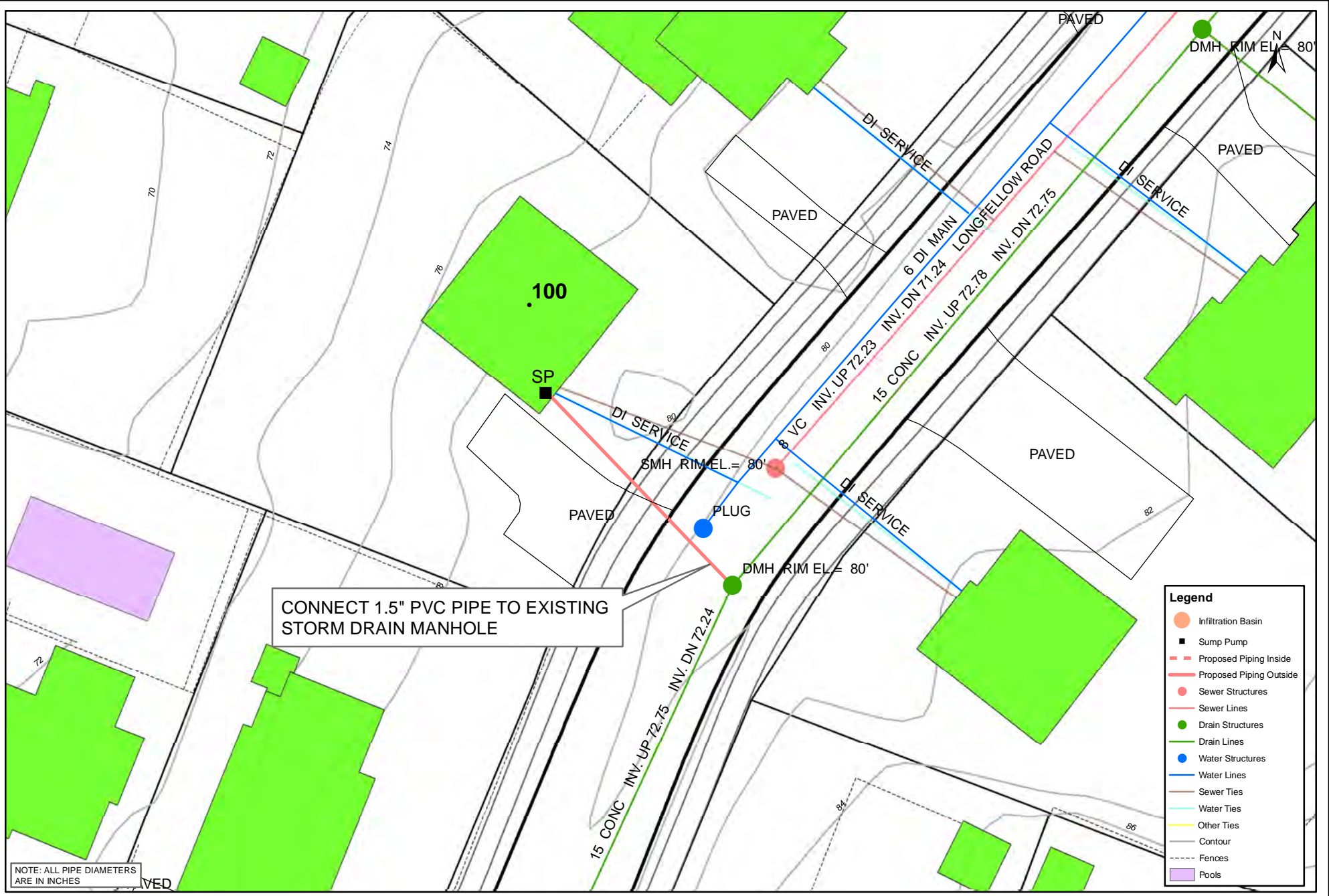

NOTE: ALL PIPE DIAMETERS ARE IN INCHES

Legend	
	Infiltration Basin
	Sump Pump
	Proposed Piping Inside
	Proposed Piping Outside
	Sewer Structures
	Sewer Lines
	Drain Structures
	Drain Lines
	Water Structures
	Water Lines
	Sewer Ties
	Water Ties
	Other Ties
	Contour
	Fences
	Pools

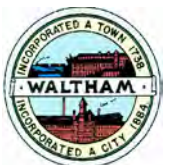

**CITY OF WALTHAM - SUMP PUMP AMNESTY PROGRAM**  
**CONTRACT 2 - AREAS 5B, 5D & 15**  
**100 LONGFELLOW ROAD**

1 inch = 25 feet





**CITY OF WALTHAM - SUMP PUMP AMNESTY PROGRAM**  
**CONTRACT 2 - AREAS 5B, 5D & 15**  
**468 LINCOLN STREET**

1 inch = 25 feet

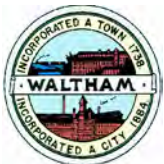

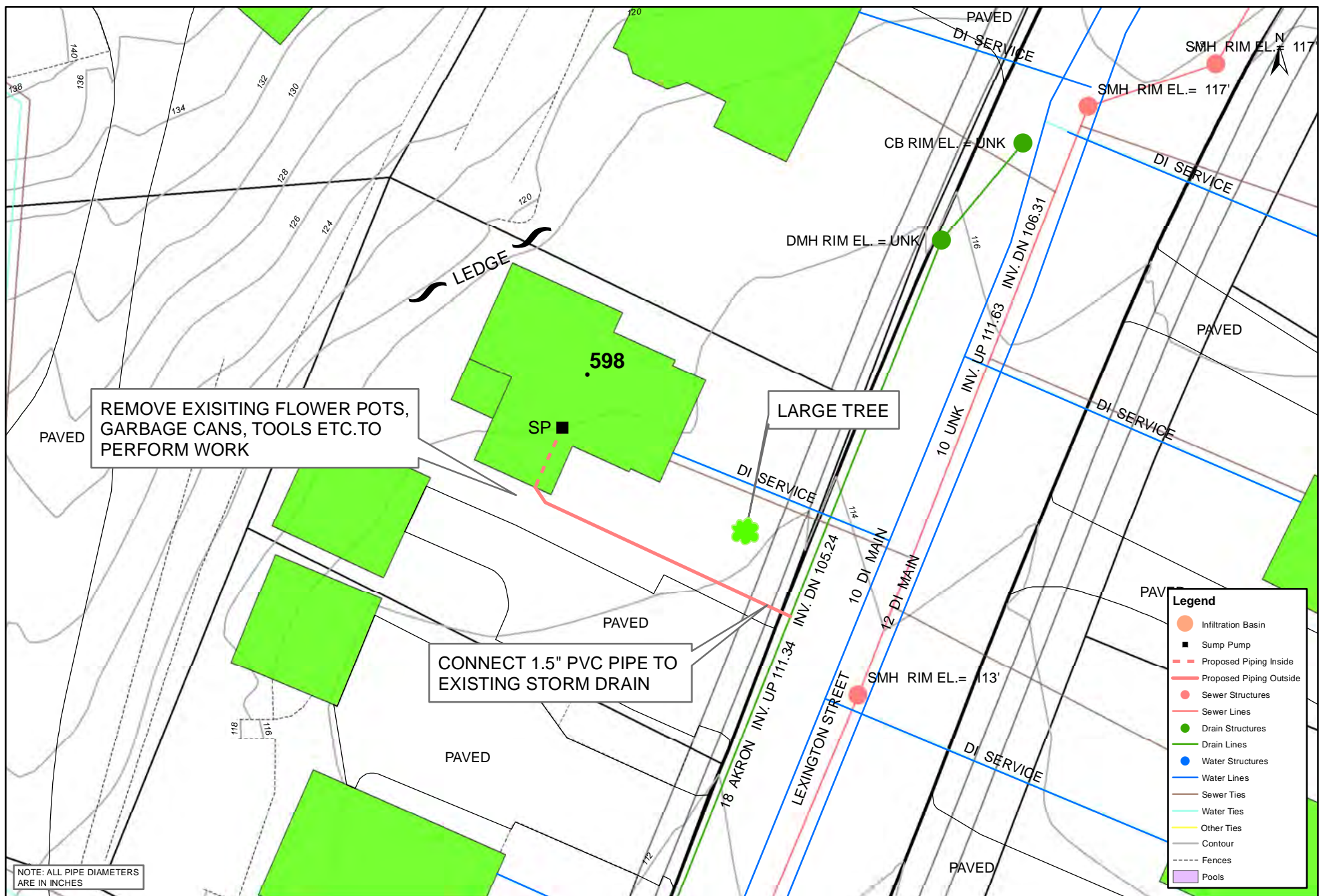

**CITY OF WALTHAM - SUMP PUMP AMNESTY PROGRAM**  
**CONTRACT 2 - AREAS 5B, 5D & 15**  
**598 LEXINGTON STREET**

1 inch = 25 feet

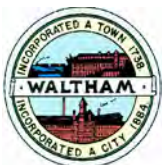

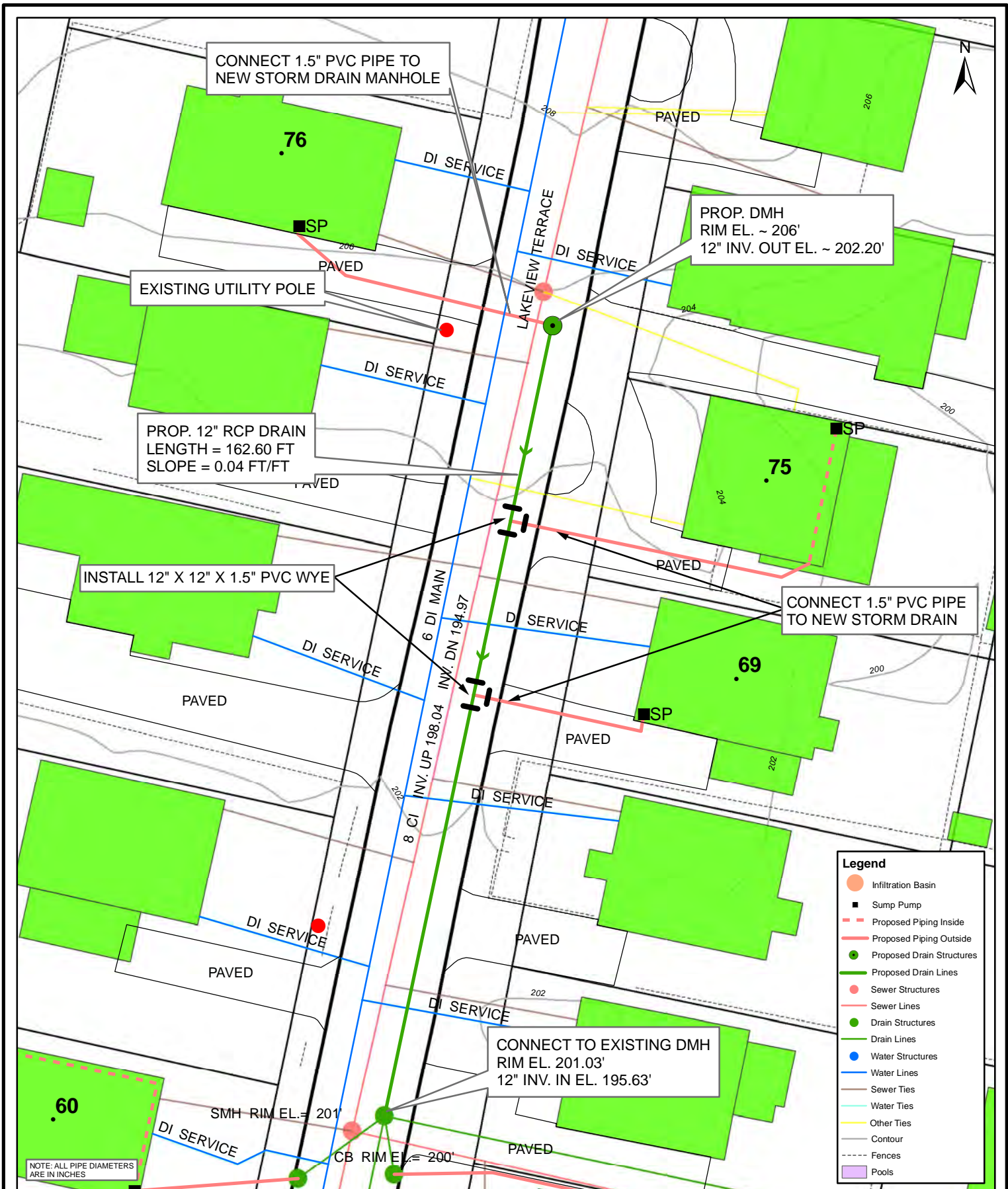

1 inch = 25 feet

**CITY OF WALTHAM - SUMP PUMP AMNESTY PROGRAM  
 CONTRACT 2 - AREAS 5B, 5D & 15  
 69, 75 & 76 LAKEVIEW TERRACE**



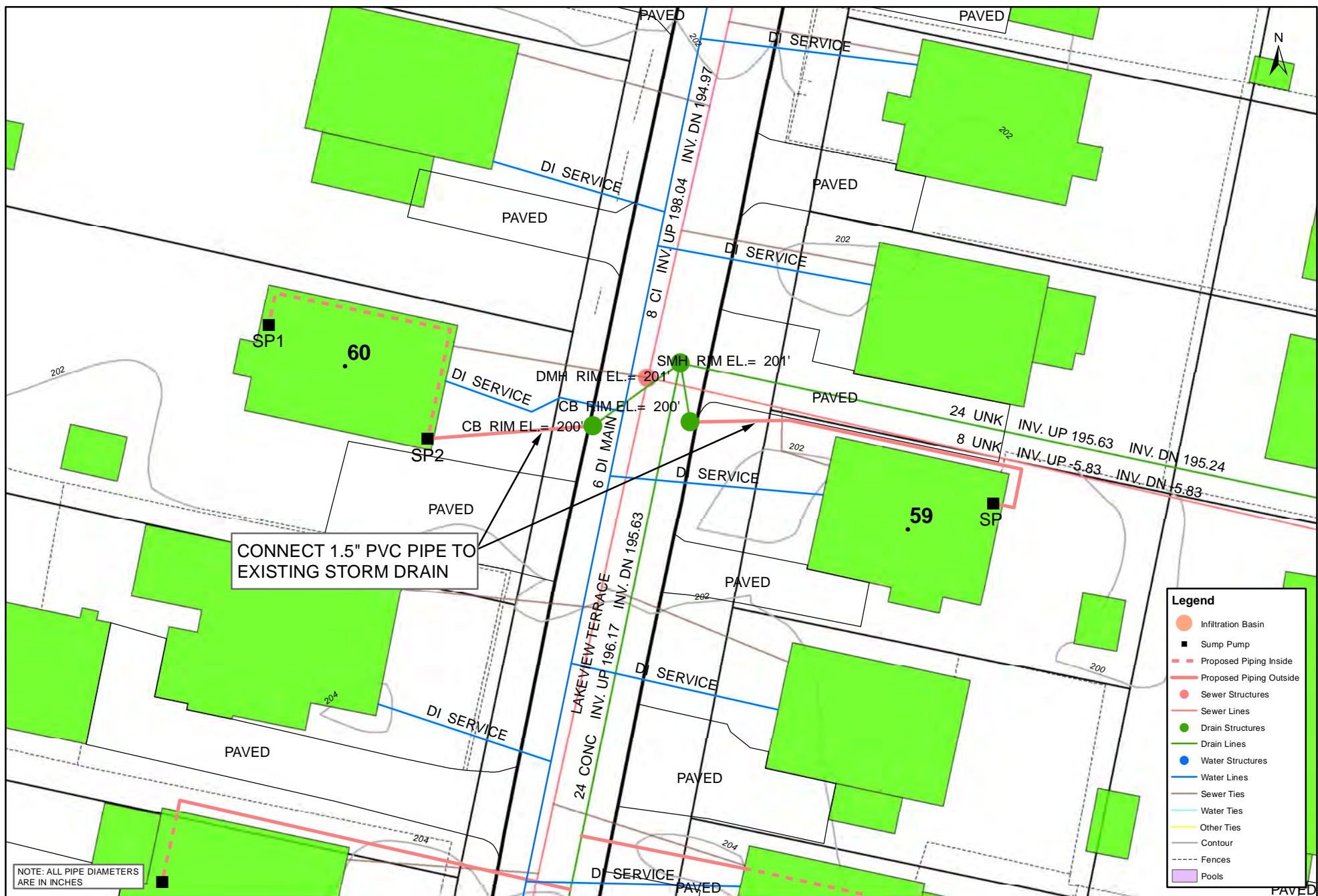

NOTE: ALL PIPE DIAMETERS ARE IN INCHES

**Legend**

- Infiltration Basin
- Sump Pump
- - - Proposed Piping Inside
- Proposed Piping Outside
- Sewer Structures
- Drain Structures
- Drain Lines
- Water Structures
- Water Lines
- Sewer Ties
- Water Ties
- Other Ties
- Contour
- Fences
- Pools

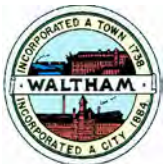

# CITY OF WALTHAM - SUMP PUMP AMNESTY PROGRAM

## CONTRACT 2 - AREAS 5B, 5D & 15

### 59 & 60 LAKEVIEW TERRACE

1 inch = 25 feet



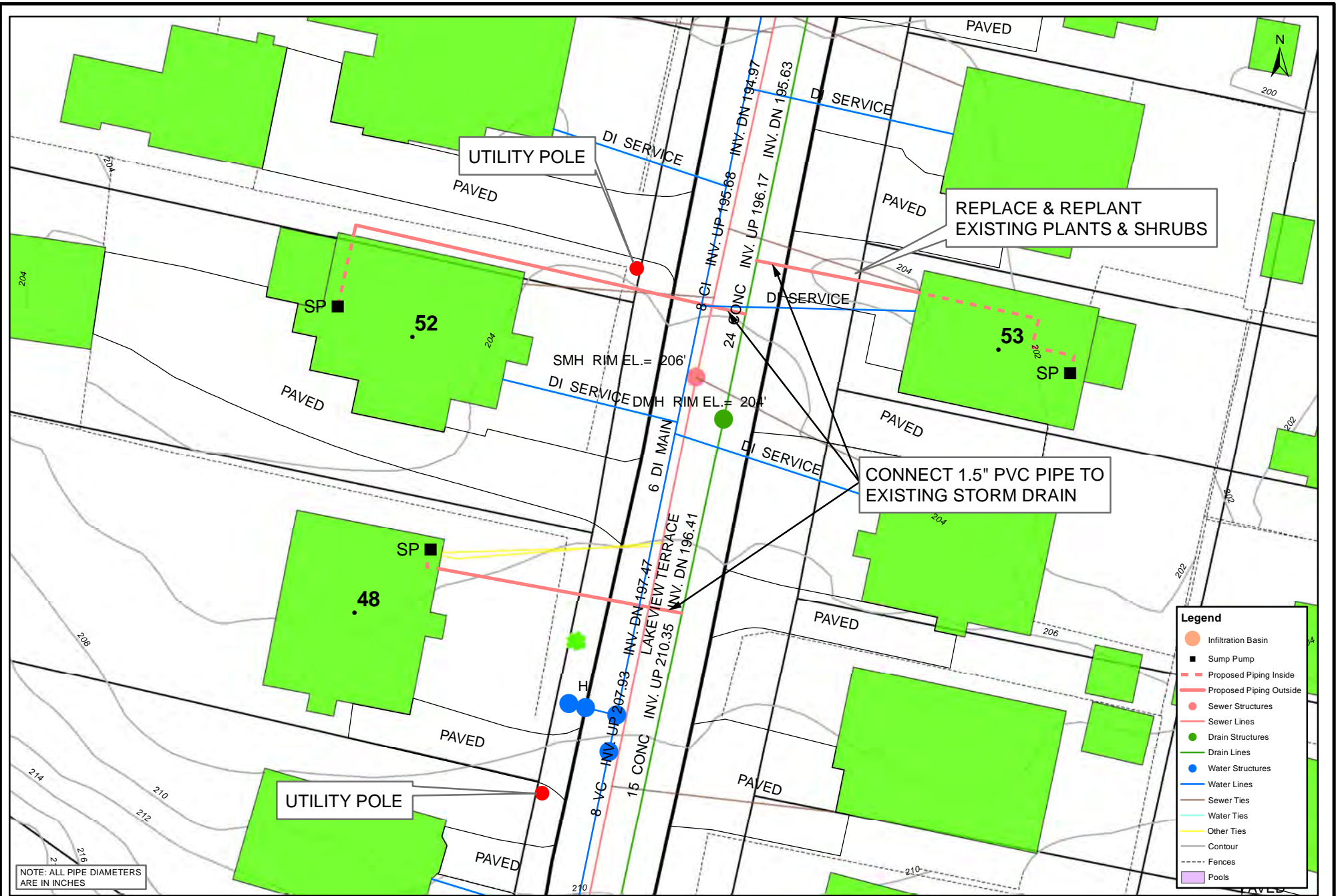

**CITY OF WALTHAM - SUMP PUMP AMNESTY PROGRAM**  
**CONTRACT 2 - AREAS 5B, 5D & 15**  
**48, 52 & 53 LAKEVIEW TERRACE**

1 inch = 25 feet

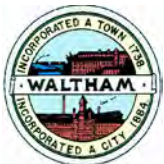





Legend	
	Infiltration Basin
	Sump Pump
	Proposed Piping Inside
	Proposed Piping Outside
	Sewer Structures
	Sewer Lines
	Drain Structures
	Drain Lines
	Water Structures
	Water Lines
	Sewer Ties
	Water Ties
	Other Ties
	Contour
	Fences
	Pools

NOTE: ALL PIPE DIAMETERS ARE IN INCHES

**CITY OF WALTHAM - SUMP PUMP AMNESTY PROGRAM**  
**CONTRACT 2 - AREAS 5B, 5D & 15**  
**133 LAKE STREET**

1 inch = 25 feet

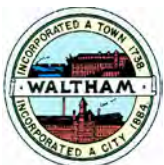

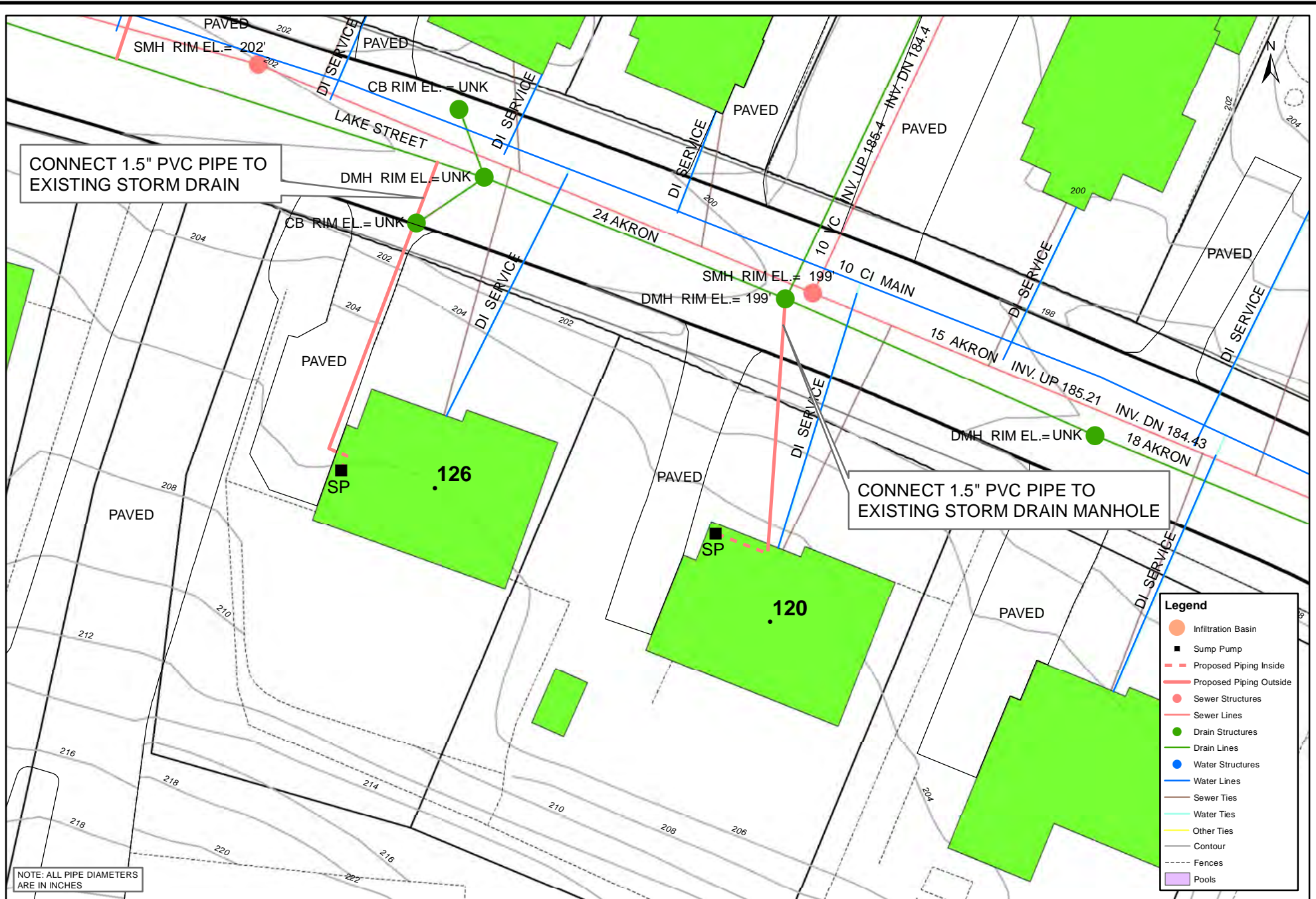

**CITY OF WALTHAM - SUMP PUMP AMNESTY PROGRAM**  
**CONTRACT 2 - AREAS 5B, 5D & 15**  
**120 & 126 LAKE STREET**

1 inch = 25 feet

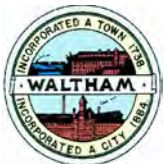

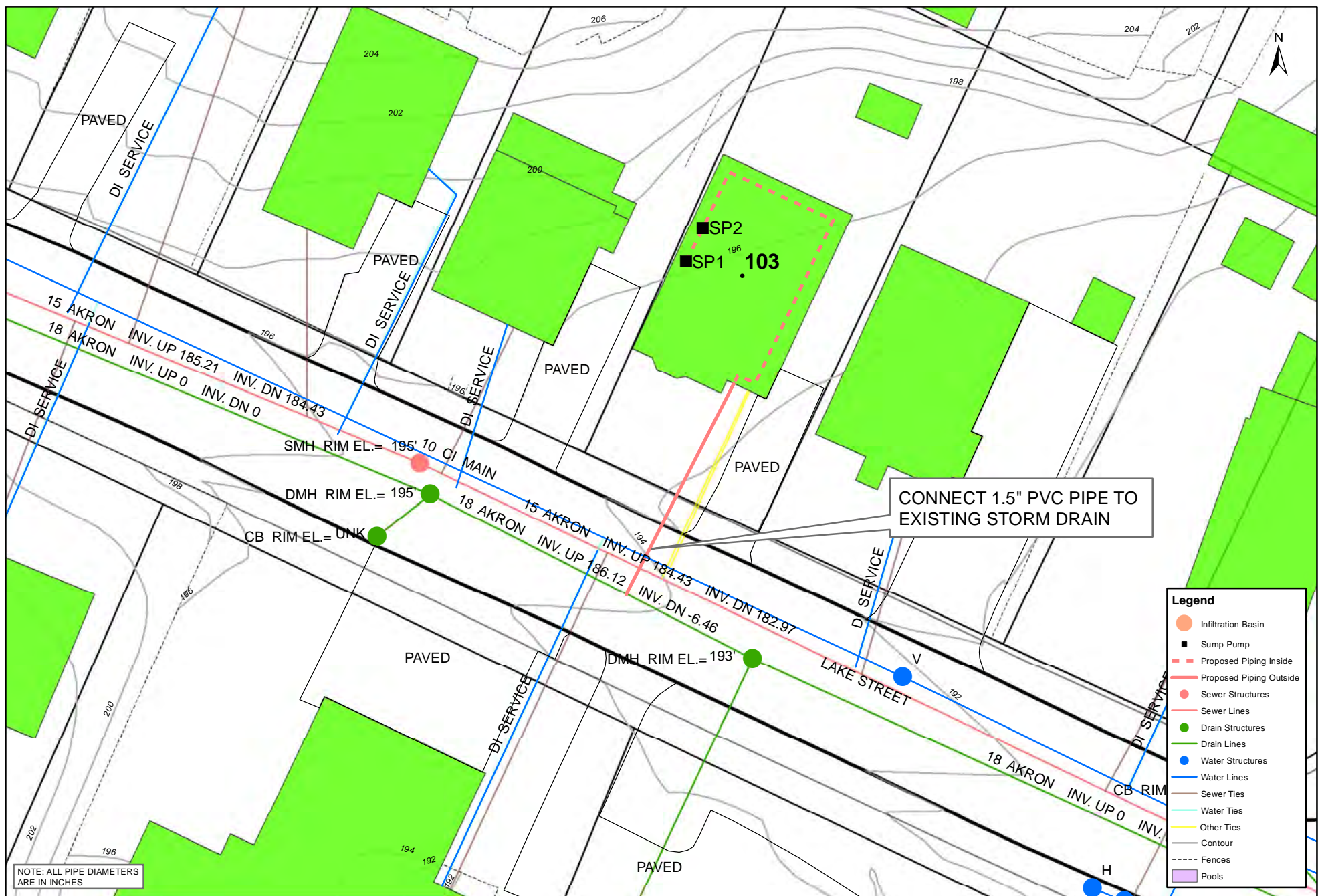

NOTE: ALL PIPE DIAMETERS ARE IN INCHES

Legend	
	Infiltration Basin
	Sump Pump
	Proposed Piping Inside
	Proposed Piping Outside
	Sewer Structures
	Sewer Lines
	Drain Structures
	Drain Lines
	Water Structures
	Water Lines
	Sewer Ties
	Water Ties
	Other Ties
	Contour
	Fences
	Pools

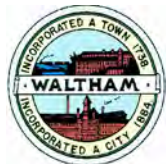

# CITY OF WALTHAM - SUMP PUMP AMNESTY PROGRAM

## CONTRACT 2 - AREAS 5B, 5D & 15

### 103 LAKE STREET

1 inch = 25 feet





NOTE: ALL PIPE DIAMETERS ARE IN INCHES

Legend	
<span style="color: orange;">●</span>	Infiltration Basin
<span style="color: black;">■</span>	Sump Pump
<span style="color: red;">---</span>	Proposed Piping Inside
<span style="color: red;">---</span>	Proposed Piping Outside
<span style="color: red;">●</span>	Sewer Structures
<span style="color: red;">---</span>	Sewer Lines
<span style="color: green;">●</span>	Drain Structures
<span style="color: green;">---</span>	Drain Lines
<span style="color: blue;">---</span>	Water Structures
<span style="color: blue;">---</span>	Water Lines
<span style="color: brown;">---</span>	Sewer Ties
<span style="color: cyan;">---</span>	Water Ties
<span style="color: yellow;">---</span>	Other Ties
<span style="color: grey;">---</span>	Contour
<span style="color: black;">---</span>	Fences
<span style="color: purple;">---</span>	Pools

**CITY OF WALTHAM - SUMP PUMP AMNESTY PROGRAM**  
**CONTRACT 2 - AREAS 5B, 5D & 15**  
**78 LAKE STREET**

1 inch = 25 feet

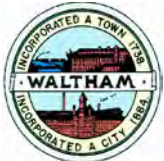



**CITY OF WALTHAM - SUMP PUMP AMNESTY PROGRAM**  
**CONTRACT 2 - AREAS 5B, 5D & 15**  
**26 LAKE STREET**

1 inch = 25 feet



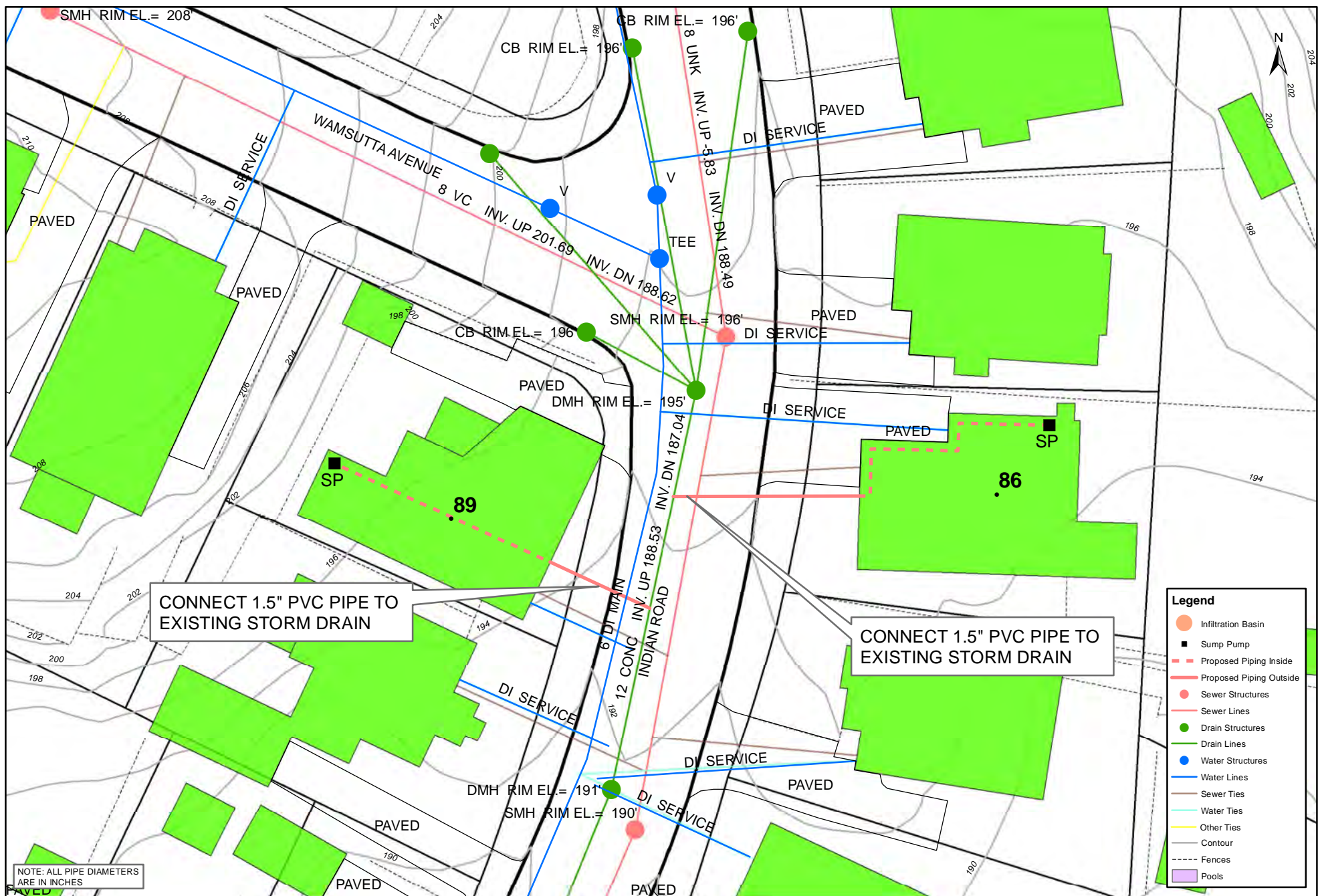

**Legend**

- Infiltration Basin
- Sump Pump
- Proposed Piping Inside
- Proposed Piping Outside
- Sewer Structures
- Sewer Lines
- Drain Structures
- Drain Lines
- Water Structures
- Water Lines
- Sewer Ties
- Water Ties
- Other Ties
- Contour
- Fences
- Pools

NOTE: ALL PIPE DIAMETERS ARE IN INCHES

**CITY OF WALTHAM - SUMP PUMP AMNESTY PROGRAM**  
**CONTRACT 2 - AREAS 5B, 5D & 15**  
**86 & 89 INDIAN ROAD**

1 inch = 25 feet

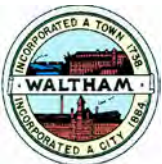

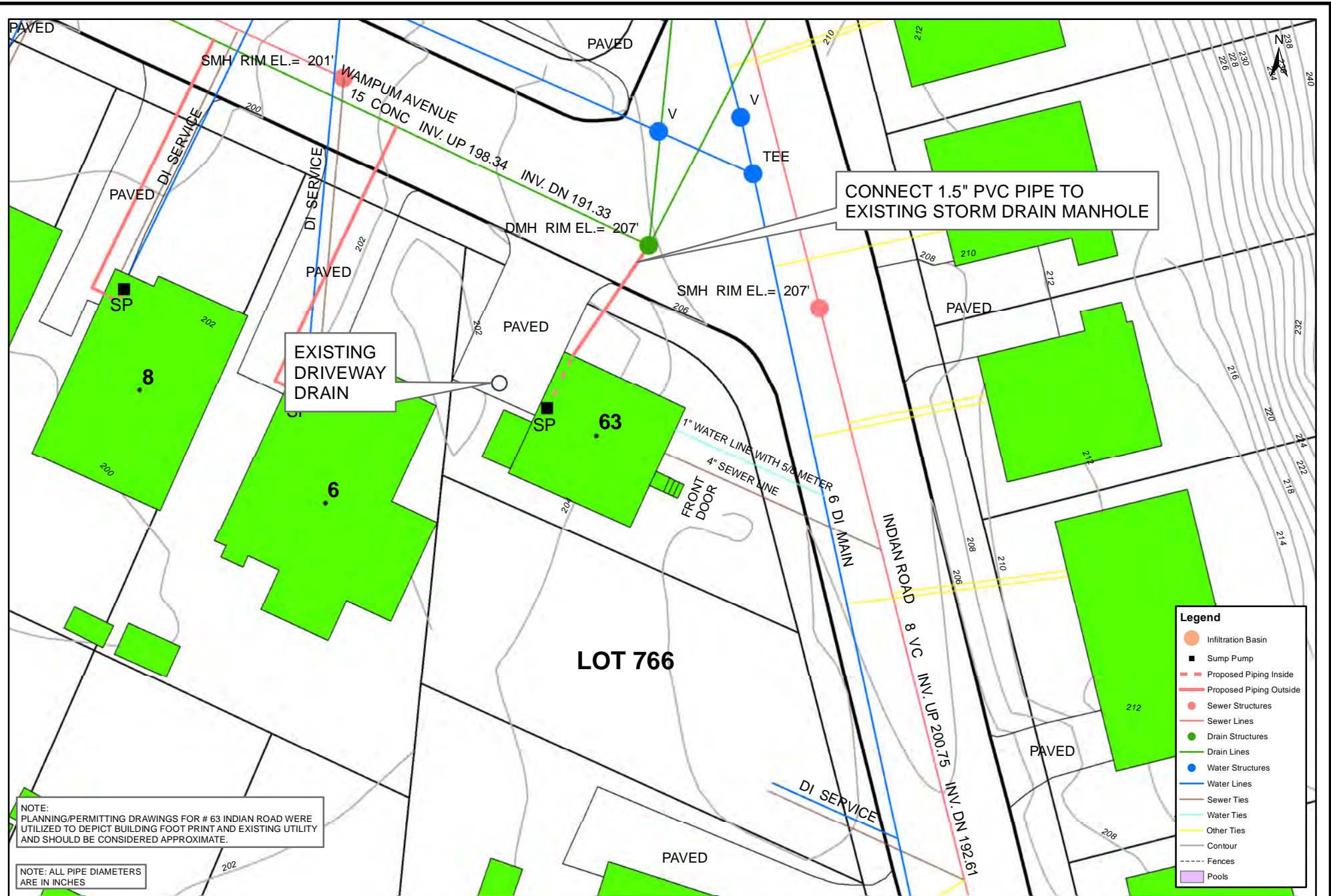

NOTE:  
PLANNING/PERMITTING DRAWINGS FOR # 63 INDIAN ROAD WERE  
UTILIZED TO DEPICT BUILDING FOOT PRINT AND EXISTING UTILITY  
AND SHOULD BE CONSIDERED APPROXIMATE.

NOTE: ALL PIPE DIAMETERS  
ARE IN INCHES

Legend	
	Infiltration Basin
	Sump Pump
	Proposed Piping Inside
	Proposed Piping Outside
	Sewer Structures
	Sewer Lines
	Drain Structures
	Drain Lines
	Water Structures
	Water Lines
	Sewer Ties
	Water Ties
	Other Ties
	Contour
	Fences
	Pools

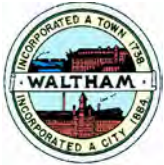

# CITY OF WALTHAM - SUMP PUMP AMNESTY PROGRAM

## CONTRACT 2 - AREAS 5B, 5D & 15

### 63 INDIAN ROAD

1 inch = 25 feet







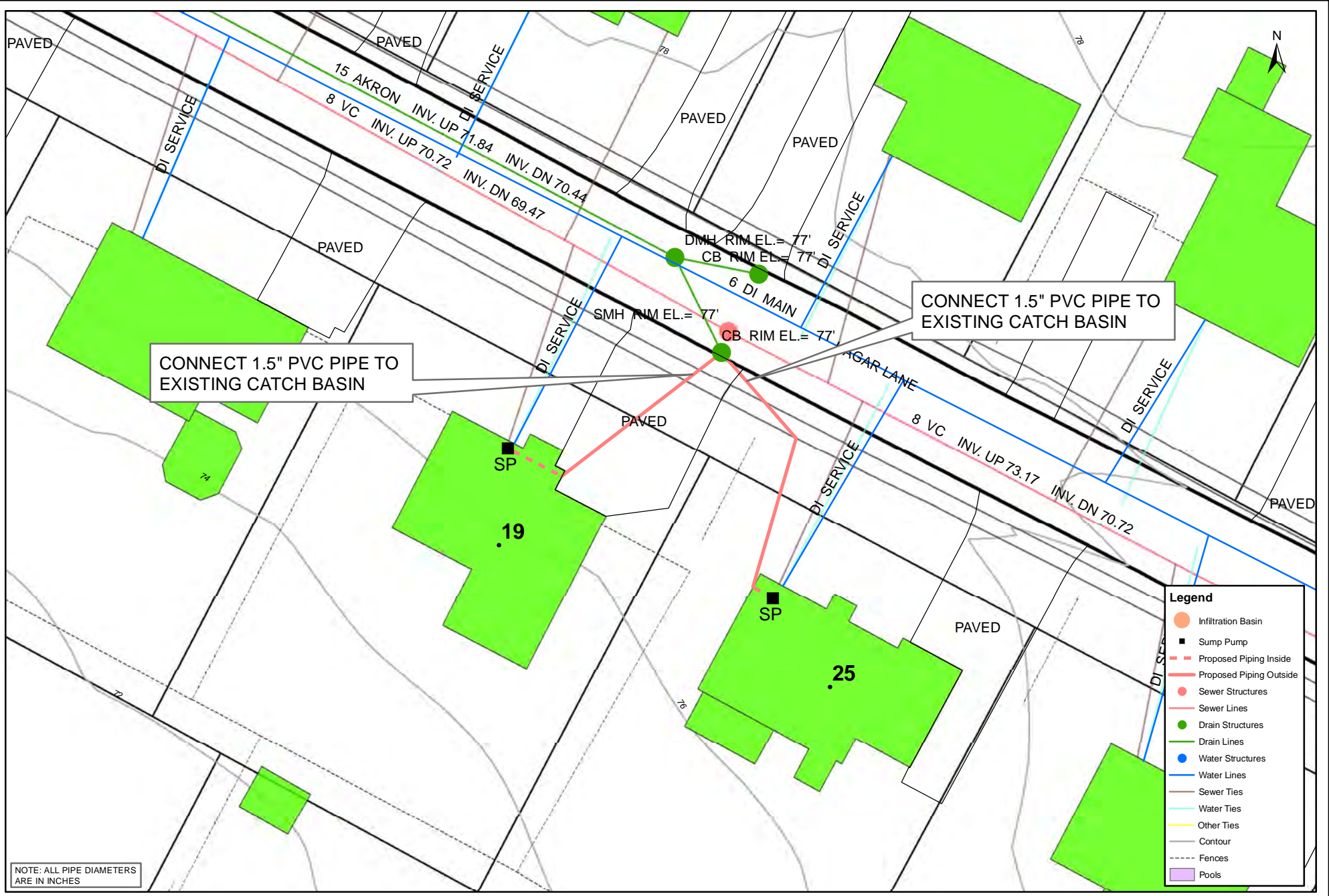

**Legend**

- Infiltration Basin
- Sump Pump
- Proposed Piping Inside
- Proposed Piping Outside
- Sewer Structures
- Sewer Lines
- Drain Structures
- Drain Lines
- Water Structures
- Water Lines
- Sewer Ties
- Water Ties
- Other Ties
- Contour
- - - Fences
- Pools

NOTE: ALL PIPE DIAMETERS ARE IN INCHES

**CITY OF WALTHAM - SUMP PUMP AMNESTY PROGRAM**  
**CONTRACT 2 - AREAS 5B, 5D & 15**  
**19 & 25 HAGAR LANE**

1 inch = 25 feet

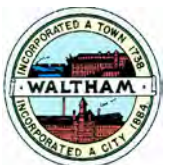



**CITY OF WALTHAM - SUMP PUMP AMNESTY PROGRAM**  
**CONTRACT 2 - AREAS 5B, 5D & 15**  
**26 GLEN CIRCLE**

1 inch = 25 feet

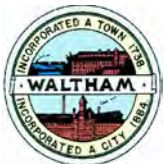

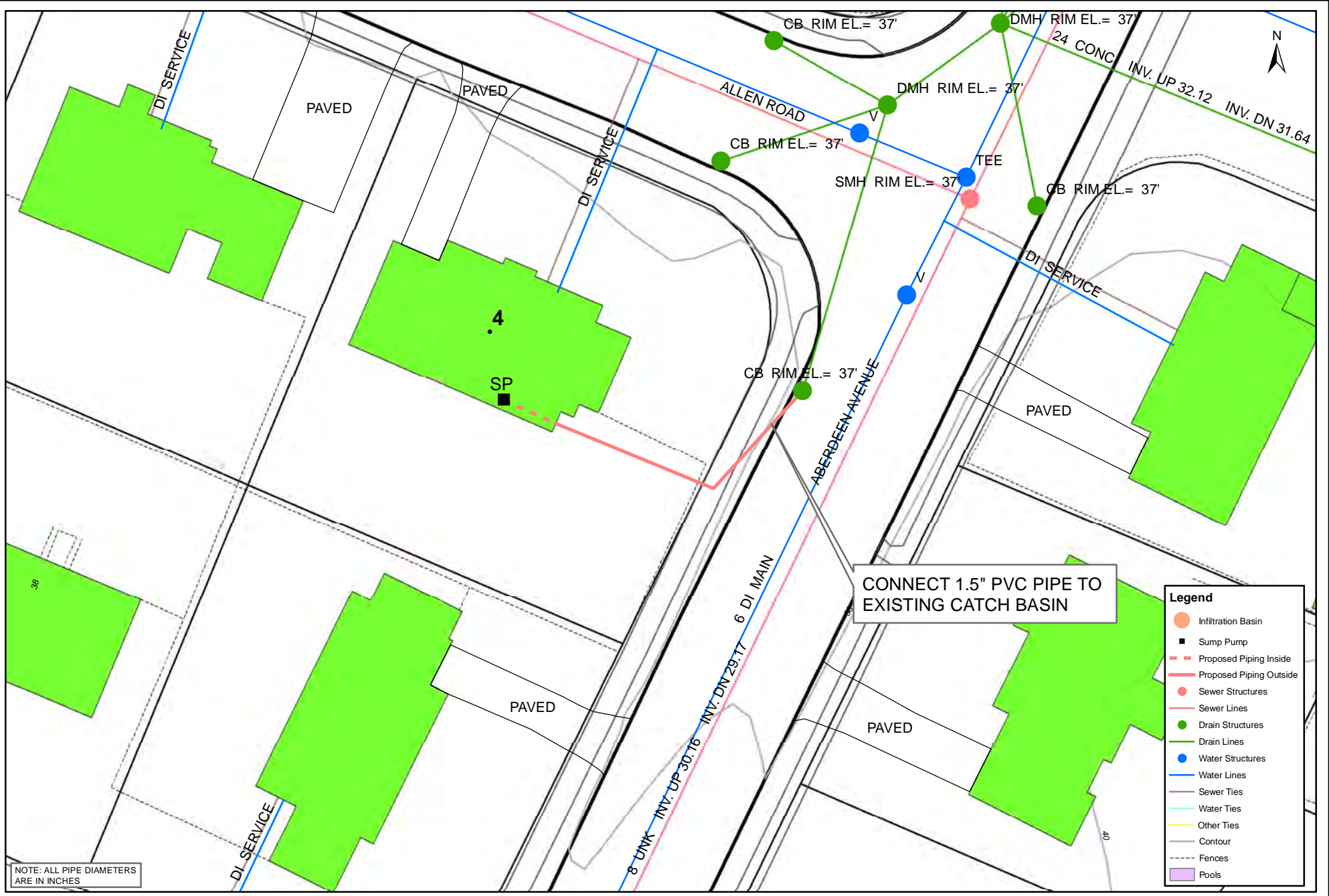

NOTE: ALL PIPE DIAMETERS ARE IN INCHES

Legend	
	Infiltration Basin
	Sump Pump
	Proposed Piping Inside
	Proposed Piping Outside
	Sewer Structures
	Sewer Lines
	Drain Structures
	Drain Lines
	Water Structures
	Water Lines
	Sewer Ties
	Water Ties
	Other Ties
	Contour
	Fences
	Pools

**CITY OF WALTHAM - SUMP PUMP AMNESTY PROGRAM**  
**CONTRACT 2 - AREAS 5B, 5D & 15**  
**4 ALLEN ROAD**

1 inch = 25 feet

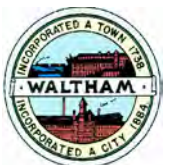



**CITY OF WALTHAM - SUMP PUMP AMNESTY PROGRAM**  
**CONTRACT 2 - AREAS 5B, 5D & 15**  
**50 AMHERST AVENUE**

1 inch = 25 feet

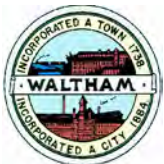



NOTE: ALL PIPE DIAMETERS ARE IN INCHES

Legend	
	Infiltration Basin
	Sump Pump
	Proposed Piping Inside
	Proposed Piping Outside
	Sewer Structures
	Sewer Lines
	Drain Structures
	Drain Lines
	Water Structures
	Water Lines
	Sewer Ties
	Water Ties
	Other Ties
	Contour
	Fences
	Pools

**CITY OF WALTHAM - SUMP PUMP AMNESTY PROGRAM**  
**CONTRACT 2 - AREAS 5B, 5D & 15**  
**74 AMHERST AVENUE**

1 inch = 25 feet

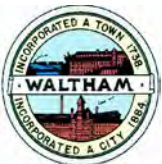

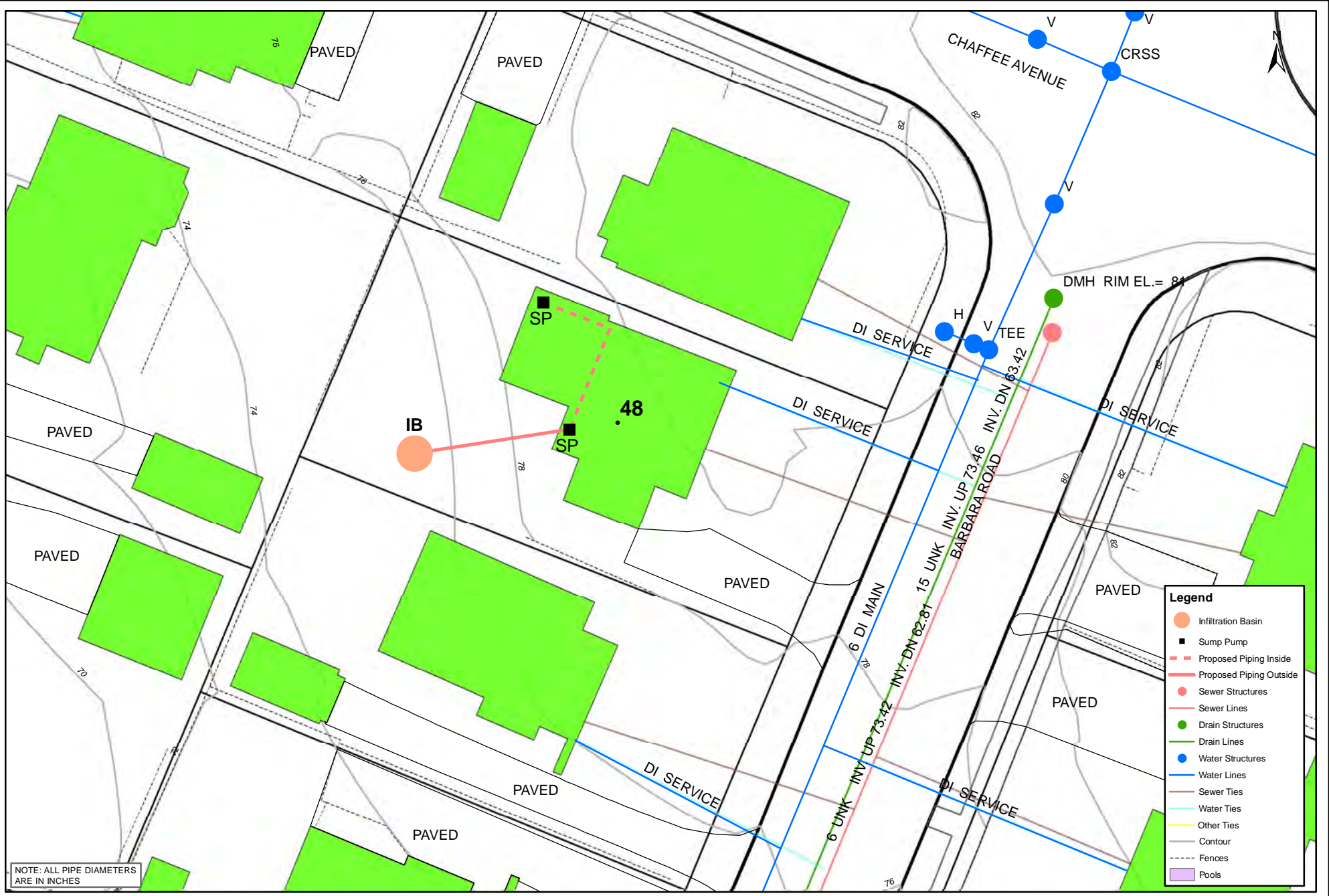

NOTE: ALL PIPE DIAMETERS ARE IN INCHES

Legend	
	Infiltration Basin
	Sump Pump
	Proposed Piping Inside
	Proposed Piping Outside
	Sewer Structures
	Sewer Lines
	Drain Structures
	Drain Lines
	Water Structures
	Water Lines
	Sewer Ties
	Water Ties
	Other Ties
	Contour
	Fences
	Pools

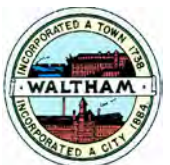

**CITY OF WALTHAM - SUMP PUMP AMNESTY PROGRAM**  
**CONTRACT 2 - AREAS 5B, 5D & 15**  
**48 BARBARA ROAD**

1 inch = 25 feet



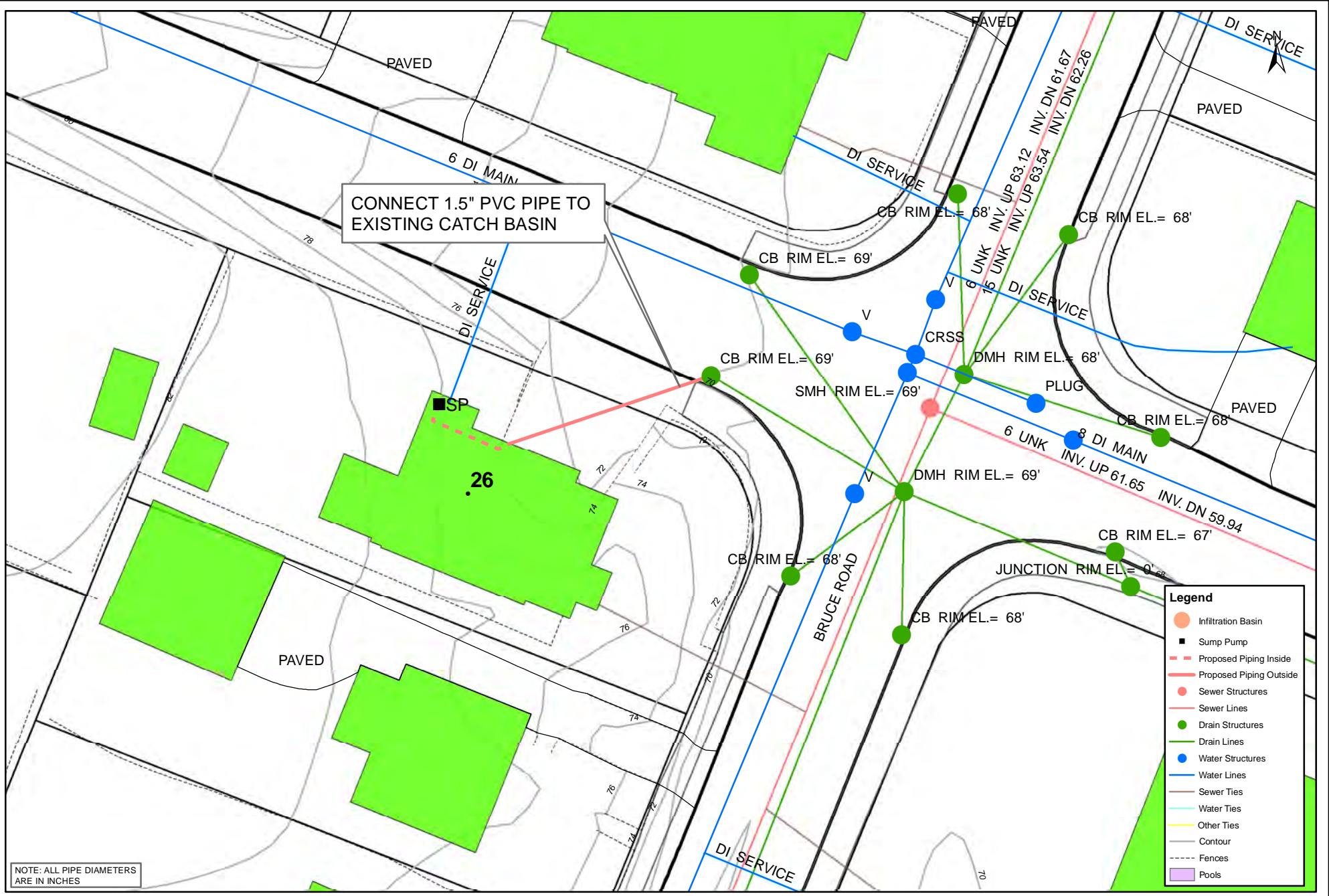

CONNECT 1.5" PVC PIPE TO EXISTING CATCH BASIN

- Legend**
- Infiltration Basin
  - Sump Pump
  - Proposed Piping Inside
  - Proposed Piping Outside
  - Sewer Structures
  - Sewer Lines
  - Drain Structures
  - Drain Lines
  - Water Structures
  - Water Lines
  - Sewer Ties
  - Water Ties
  - Other Ties
  - Contour
  - - - Fences
  - Pools

NOTE: ALL PIPE DIAMETERS ARE IN INCHES

**CITY OF WALTHAM - SUMP PUMP AMNESTY PROGRAM**  
**CONTRACT 2 - AREAS 5B, 5D & 15**  
**26 BRUCE ROAD**

1 inch = 25 feet

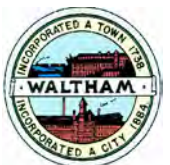

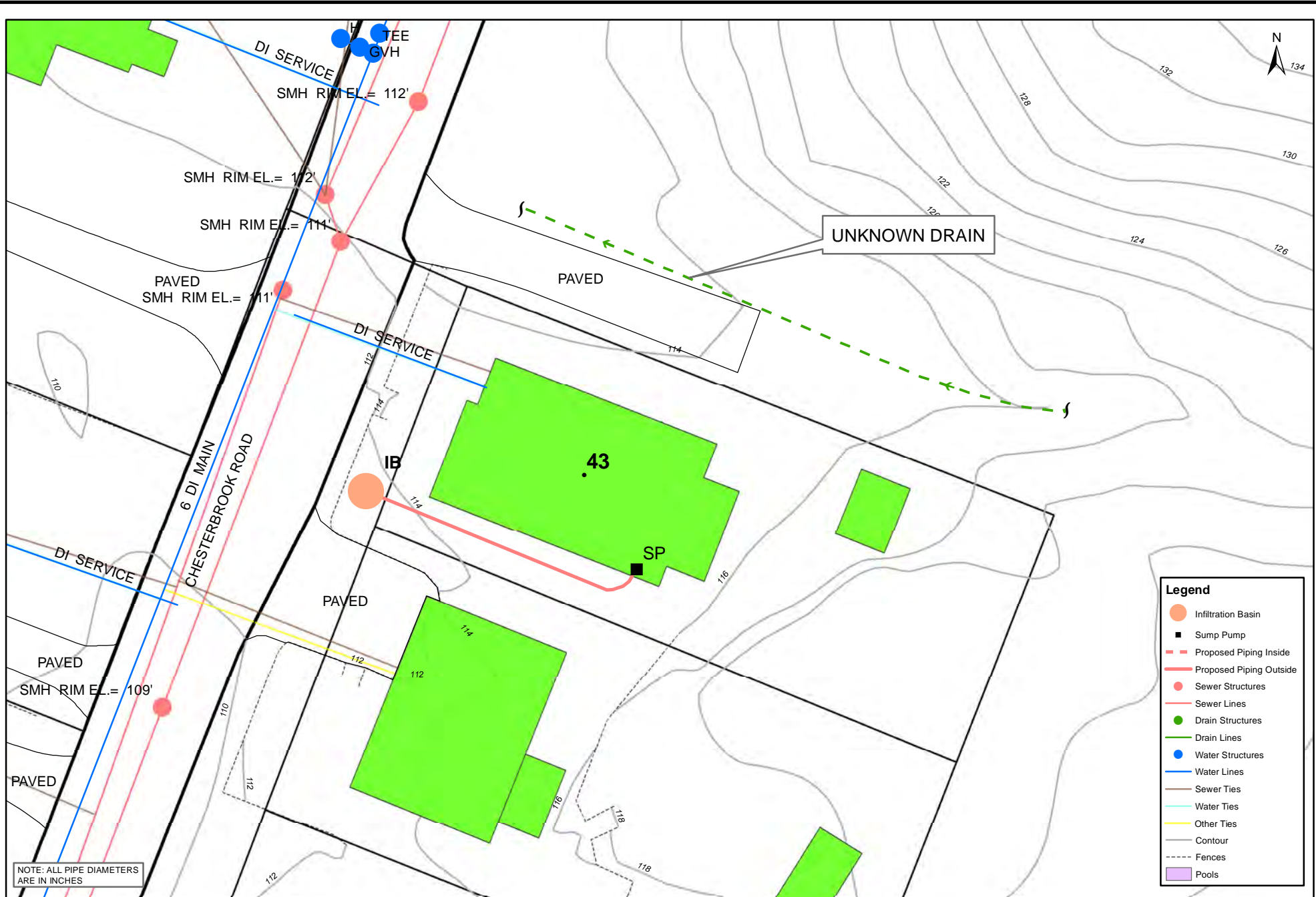

**CITY OF WALTHAM - SUMP PUMP AMNESTY PROGRAM**  
**CONTRACT 2 - AREAS 5B, 5D & 15**  
**43 CHESTERBROOK AVENUE**

1 inch = 25 feet

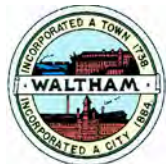



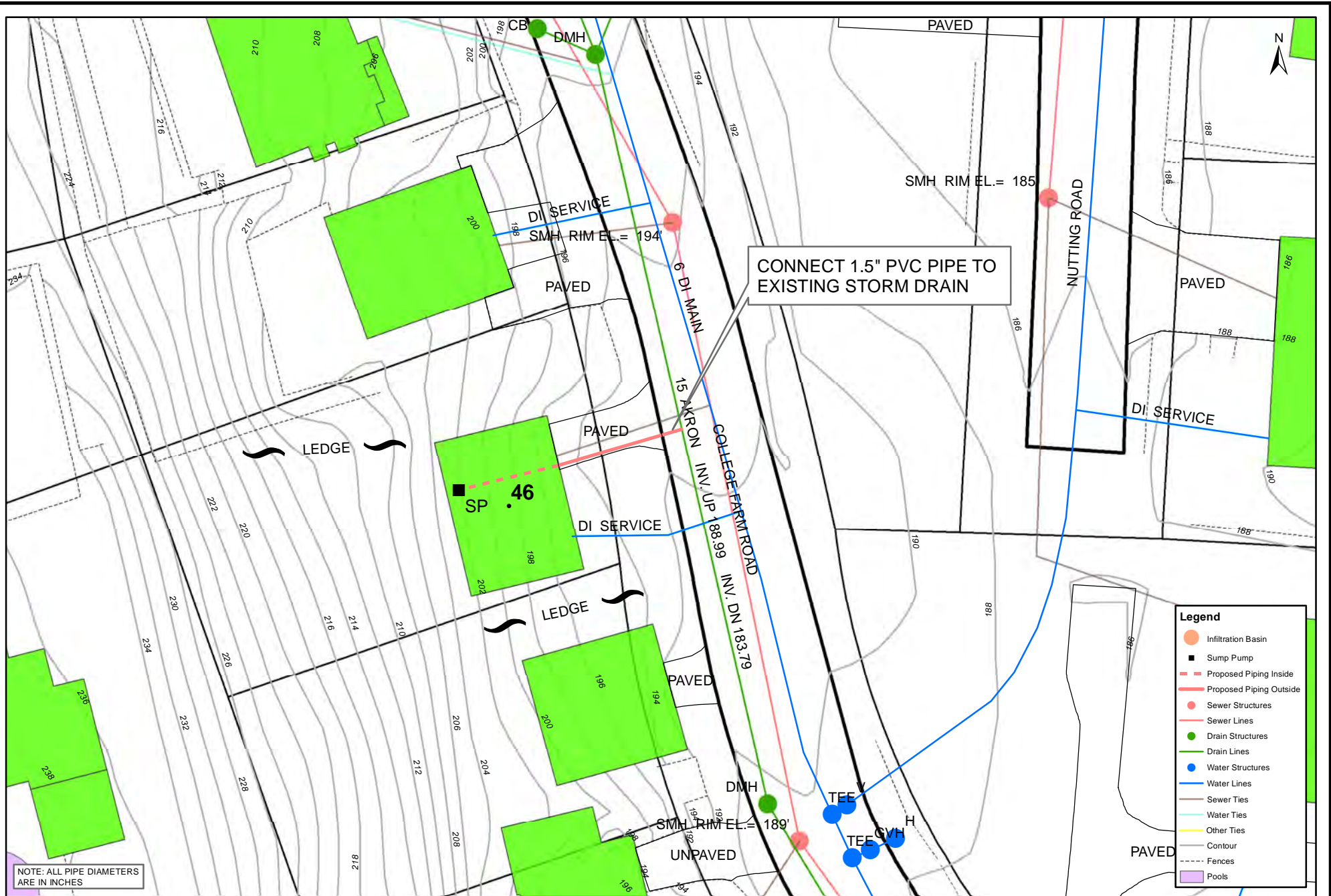

NOTE: ALL PIPE DIAMETERS ARE IN INCHES

Legend	
	Infiltration Basin
	Sump Pump
	Proposed Piping Inside
	Proposed Piping Outside
	Sewer Structures
	Sewer Lines
	Drain Structures
	Drain Lines
	Water Structures
	Water Lines
	Sewer Ties
	Water Ties
	Other Ties
	Contour
	Fences
	Pools

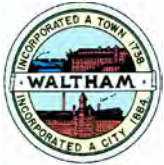

**CITY OF WALTHAM - SUMP PUMP AMNESTY PROGRAM**  
**CONTRACT 2 - AREAS 5B, 5D & 15**  
**46 COLLEGE FARM ROAD**

1 inch = 25 feet





**CITY OF WALTHAM - SUMP PUMP AMNESTY PROGRAM**  
**CONTRACT 2 - AREAS 5B, 5D & 15**  
**26 GLEN CIRCLE**

1 inch = 25 feet

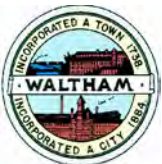

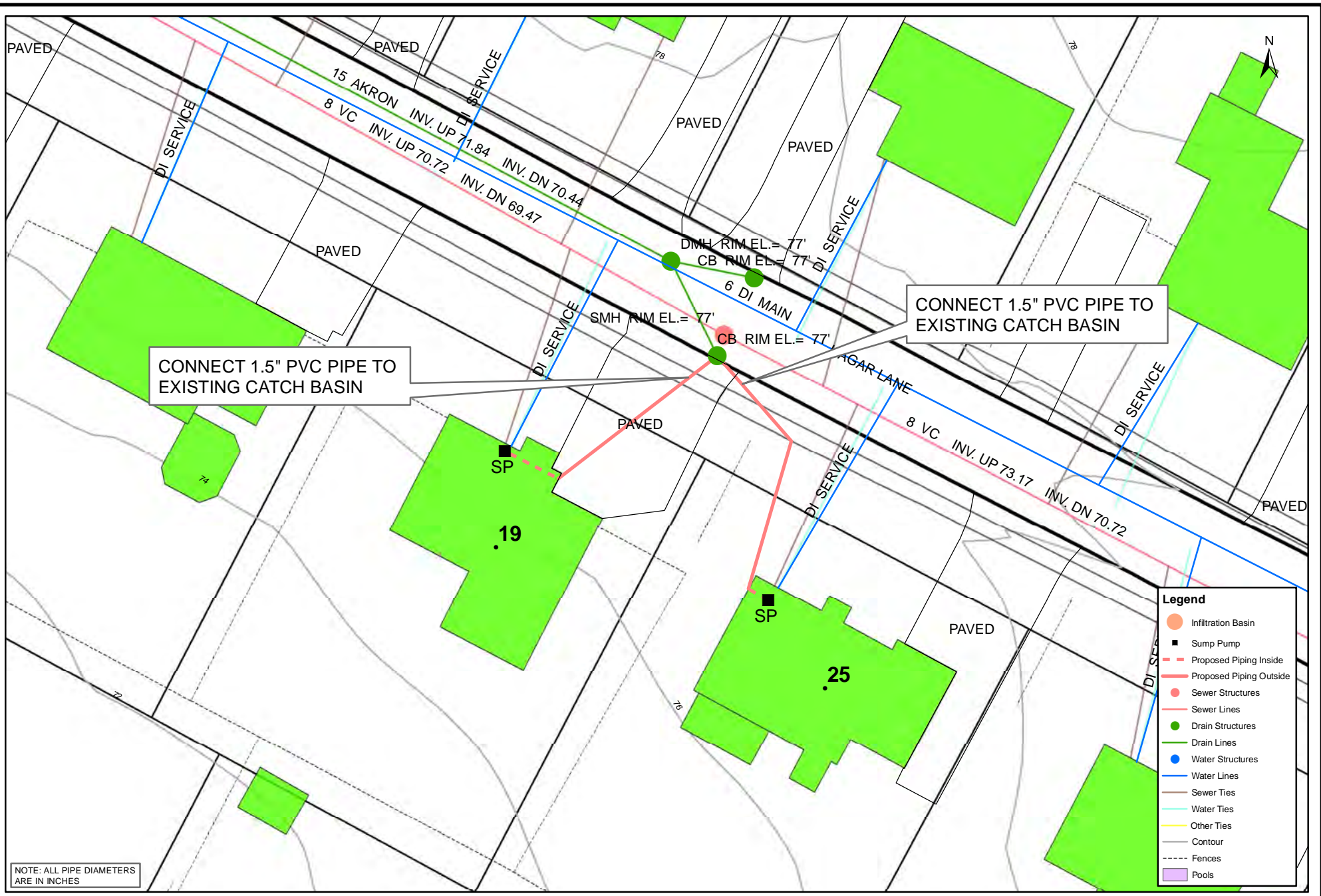

CONNECT 1.5" PVC PIPE TO EXISTING CATCH BASIN

CONNECT 1.5" PVC PIPE TO EXISTING CATCH BASIN

- Legend**
- Infiltration Basin
  - Sump Pump
  - Proposed Piping Inside
  - Proposed Piping Outside
  - Sewer Structures
  - Sewer Lines
  - Drain Structures
  - Drain Lines
  - Water Structures
  - Water Lines
  - Sewer Ties
  - Water Ties
  - Other Ties
  - Contour
  - - - Fences
  - Pools

NOTE: ALL PIPE DIAMETERS ARE IN INCHES

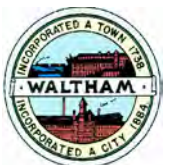

**CITY OF WALTHAM - SUMP PUMP AMNESTY PROGRAM**  
**CONTRACT 2 - AREAS 5B, 5D & 15**  
**19 & 25 HAGAR LANE**

1 inch = 25 feet





DISCONNECT AREA  
DRAIN FROM SEWER

REDIRECT AREA  
DRAIN TO SUMP PUMP

SMH RIM EL.= 234'

NOTE: ALL PIPE DIAMETERS  
ARE IN INCHES

- Legend**
- Infiltration Basin
  - Sump Pump
  - Proposed Piping Inside
  - Proposed Piping Outside
  - Sewer Structures
  - Drain Structures
  - Drain Lines
  - Water Structures
  - Water Lines
  - Sewer Ties
  - Water Ties
  - Other Ties
  - Contour
  - - - Fences
  - Pools

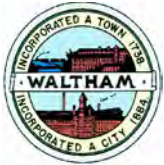

**CITY OF WALTHAM - SUMP PUMP AMNESTY PROGRAM**  
**CONTRACT 2 - AREAS 5B, 5D & 15**  
**28 HIBISCUS AVENUE**

1 inch = 25 feet



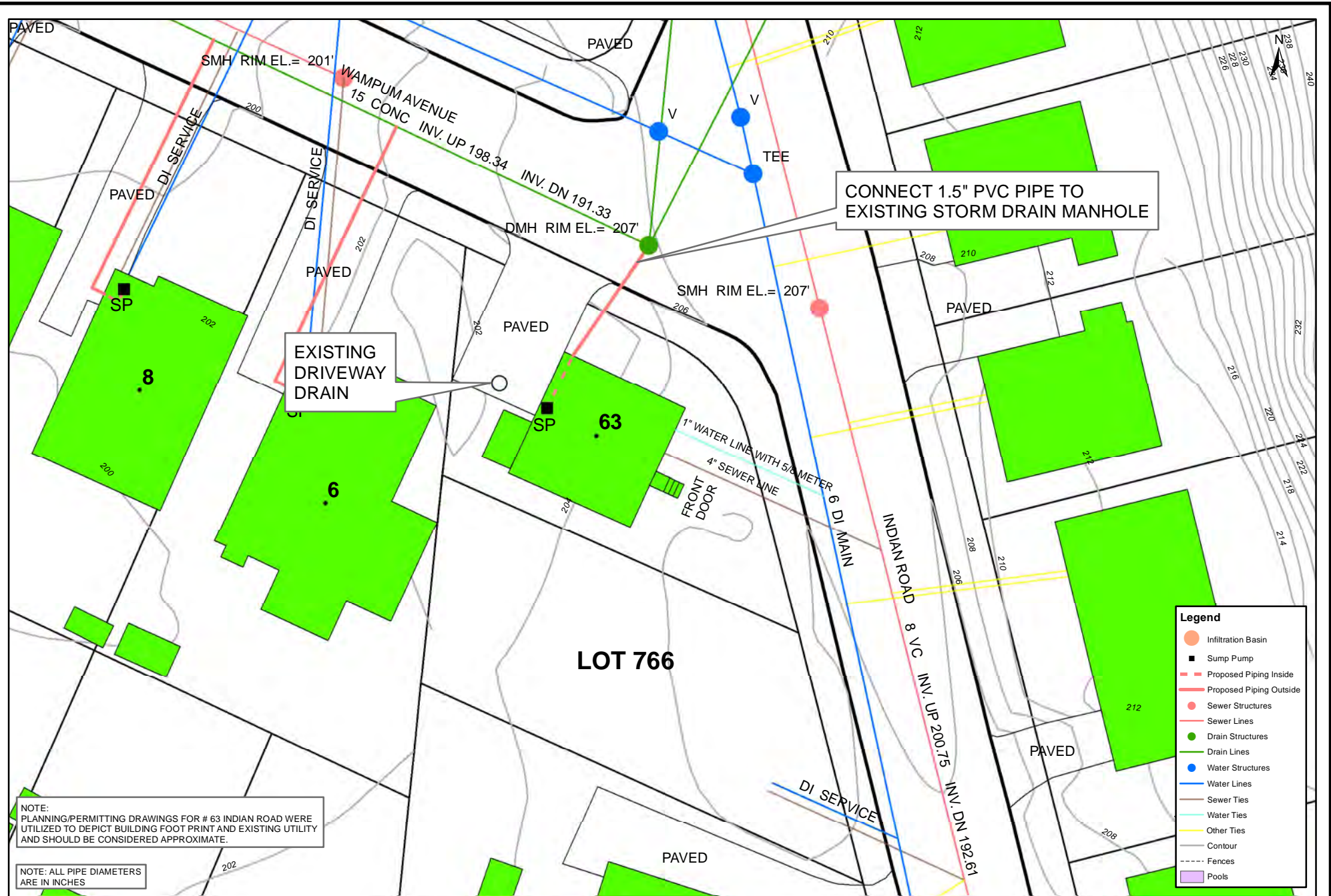

NOTE:  
PLANNING/PERMITTING DRAWINGS FOR # 63 INDIAN ROAD WERE  
UTILIZED TO DEPICT BUILDING FOOT PRINT AND EXISTING UTILITY  
AND SHOULD BE CONSIDERED APPROXIMATE.

NOTE: ALL PIPE DIAMETERS  
ARE IN INCHES

Legend	
	Infiltration Basin
	Sump Pump
	Proposed Piping Inside
	Proposed Piping Outside
	Sewer Structures
	Sewer Lines
	Drain Structures
	Drain Lines
	Water Structures
	Water Lines
	Sewer Ties
	Water Ties
	Other Ties
	Contour
	Fences
	Pools

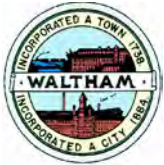

**CITY OF WALTHAM - SUMP PUMP AMNESTY PROGRAM**  
**CONTRACT 2 - AREAS 5B, 5D & 15**  
**63 INDIAN ROAD**

1 inch = 25 feet



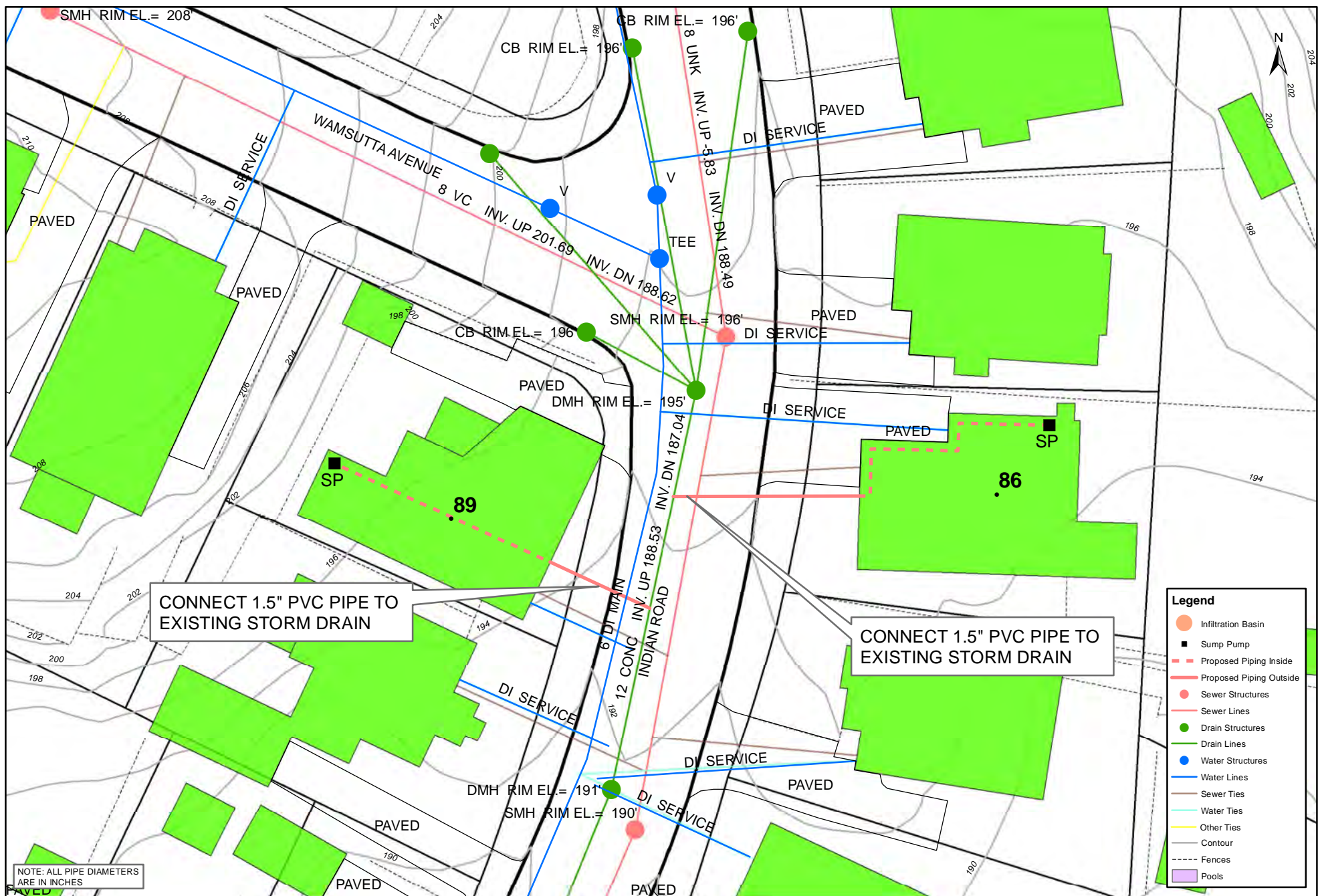

**Legend**

- Infiltration Basin
- Sump Pump
- Proposed Piping Inside
- Proposed Piping Outside
- Sewer Structures
- Sewer Lines
- Drain Structures
- Drain Lines
- Water Structures
- Water Lines
- Sewer Ties
- Water Ties
- Other Ties
- Contour
- Fences
- Pools

CONNECT 1.5" PVC PIPE TO EXISTING STORM DRAIN

CONNECT 1.5" PVC PIPE TO EXISTING STORM DRAIN

NOTE: ALL PIPE DIAMETERS ARE IN INCHES

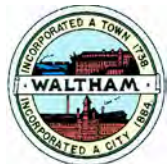

**CITY OF WALTHAM - SUMP PUMP AMNESTY PROGRAM**  
**CONTRACT 2 - AREAS 5B, 5D & 15**  
**86 & 89 INDIAN ROAD**

1 inch = 25 feet





NOTE: ALL PIPE DIAMETERS ARE IN INCHES

**CITY OF WALTHAM - SUMP PUMP AMNESTY PROGRAM**  
**CONTRACT 2 - AREAS 5B, 5D & 15**  
**26 LAKE STREET**

1 inch = 25 feet

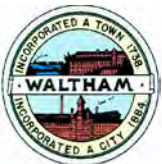



NOTE: ALL PIPE DIAMETERS ARE IN INCHES

Legend	
	Infiltration Basin
	Sump Pump
	Proposed Piping Inside
	Proposed Piping Outside
	Sewer Structures
	Sewer Lines
	Drain Structures
	Drain Lines
	Water Structures
	Water Lines
	Sewer Ties
	Water Ties
	Other Ties
	Contour
	Fences
	Pools

**CITY OF WALTHAM - SUMP PUMP AMNESTY PROGRAM**  
**CONTRACT 2 - AREAS 5B, 5D & 15**  
**78 LAKE STREET**

1 inch = 25 feet

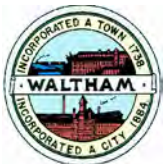



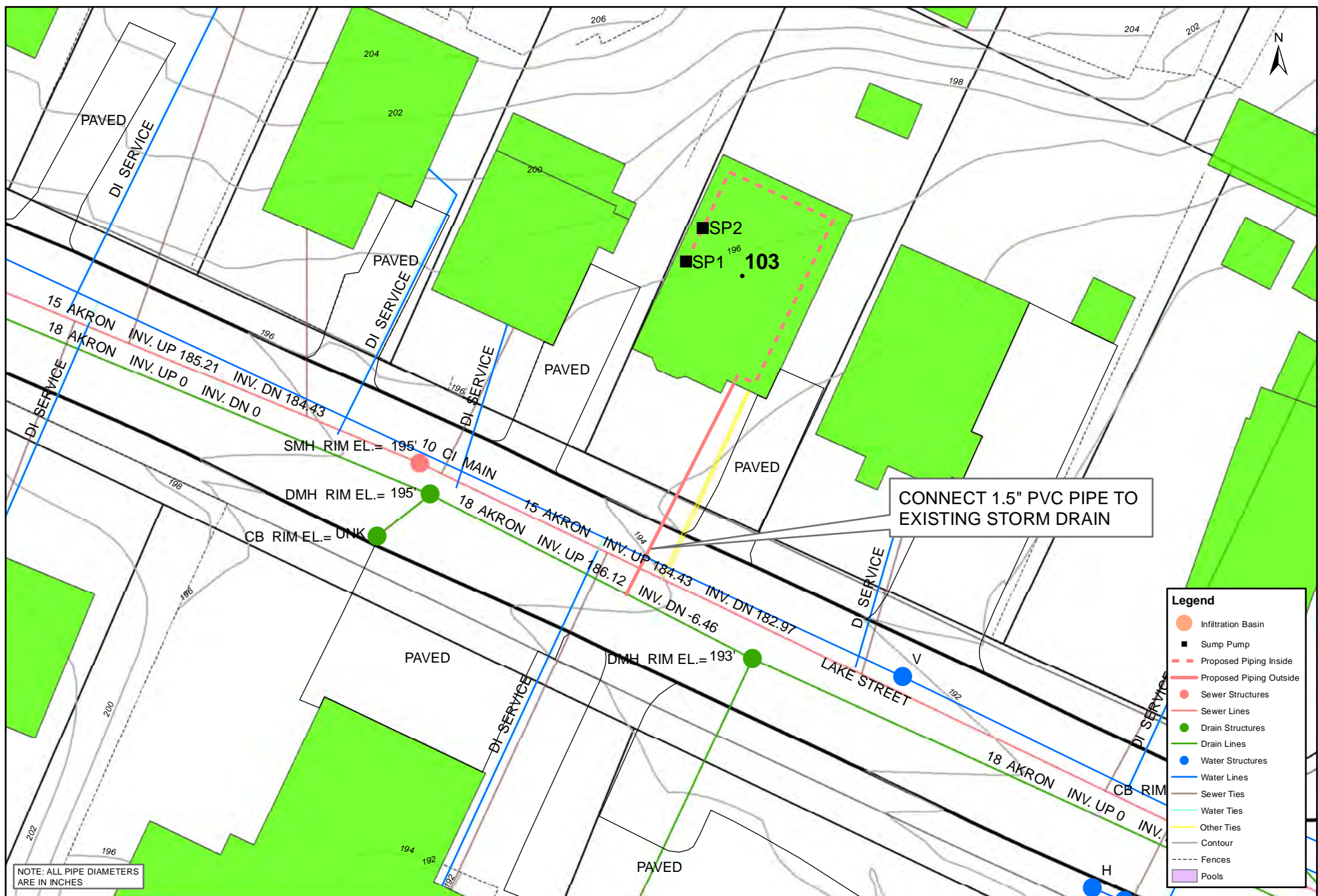

NOTE: ALL PIPE DIAMETERS ARE IN INCHES

Legend	
	Infiltration Basin
	Sump Pump
	Proposed Piping Inside
	Proposed Piping Outside
	Sewer Structures
	Sewer Lines
	Drain Structures
	Drain Lines
	Water Structures
	Water Lines
	Sewer Ties
	Water Ties
	Other Ties
	Contour
	Fences
	Pools

**CITY OF WALTHAM - SUMP PUMP AMNESTY PROGRAM**  
**CONTRACT 2 - AREAS 5B, 5D & 15**  
**103 LAKE STREET**

1 inch = 25 feet

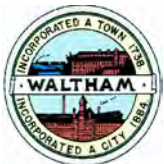

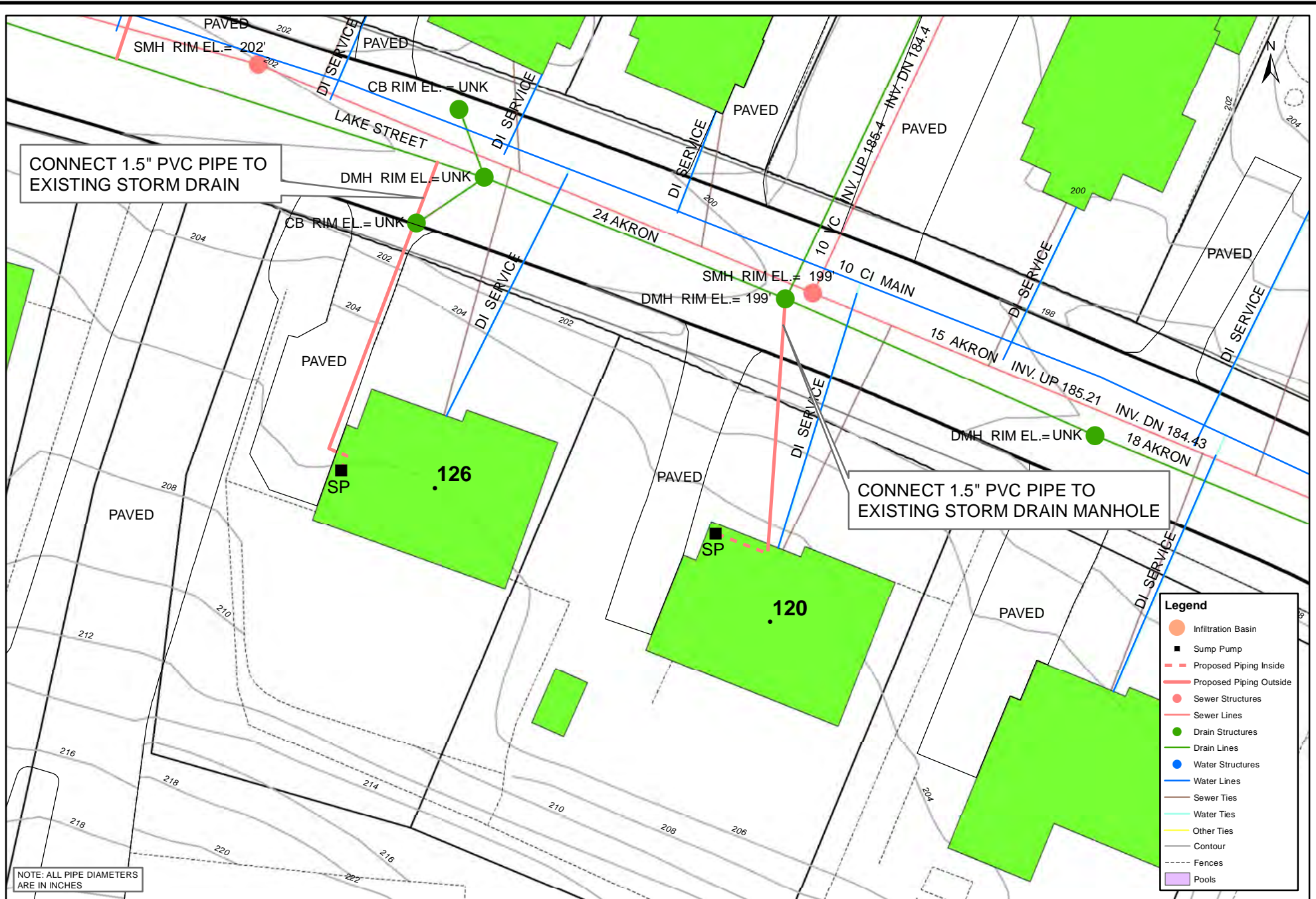

**CITY OF WALTHAM - SUMP PUMP AMNESTY PROGRAM**  
**CONTRACT 2 - AREAS 5B, 5D & 15**  
**120 & 126 LAKE STREET**

1 inch = 25 feet

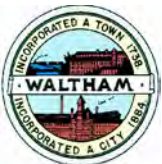



Legend	
	Infiltration Basin
	Sump Pump
	Proposed Piping Inside
	Proposed Piping Outside
	Sewer Structures
	Sewer Lines
	Drain Structures
	Drain Lines
	Water Structures
	Water Lines
	Sewer Ties
	Water Ties
	Other Ties
	Contour
	Fences
	Pools

NOTE: ALL PIPE DIAMETERS ARE IN INCHES

**CITY OF WALTHAM - SUMP PUMP AMNESTY PROGRAM**  
**CONTRACT 2 - AREAS 5B, 5D & 15**  
**133 LAKE STREET**

1 inch = 25 feet

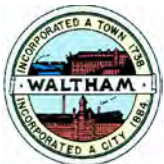

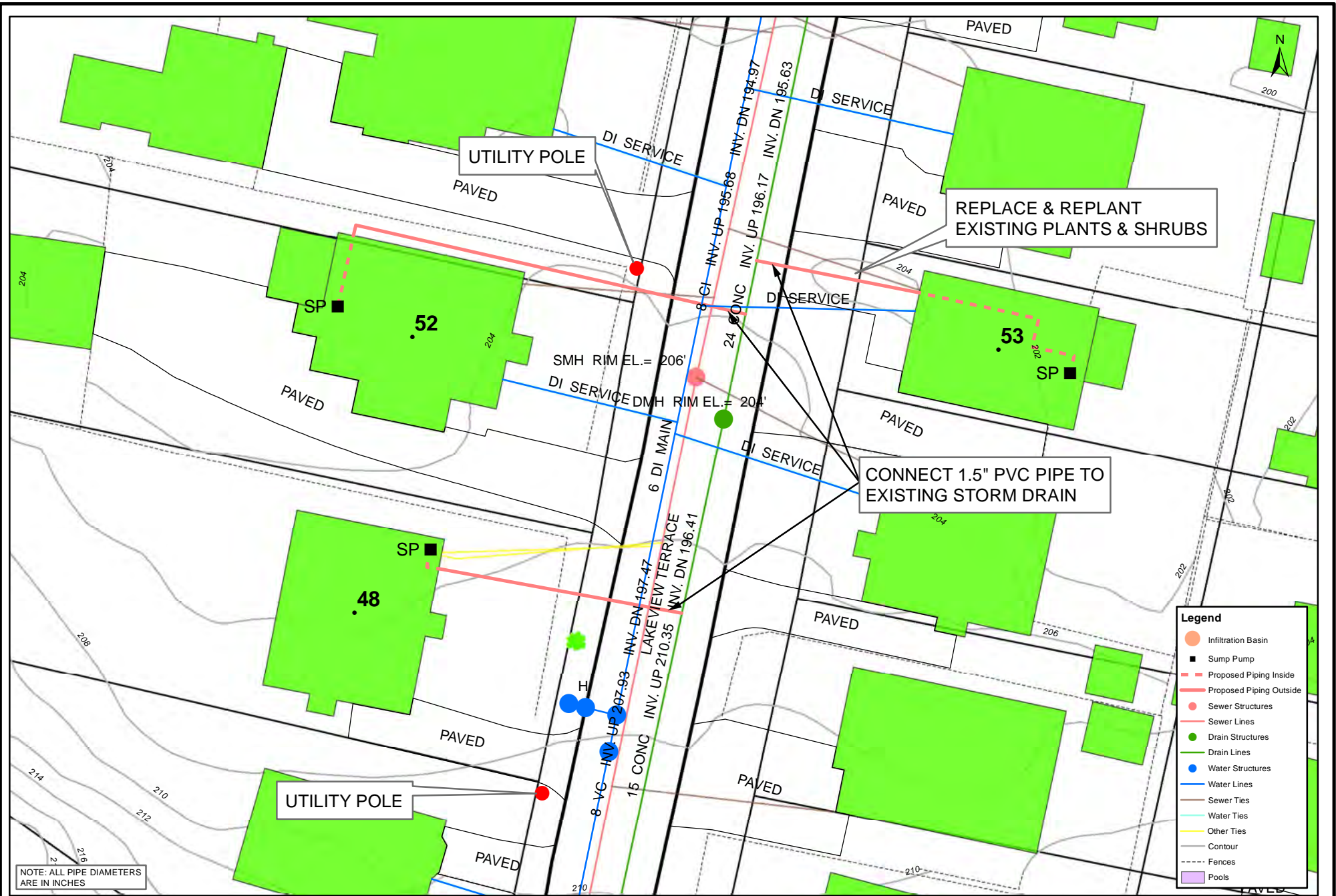

NOTE: ALL PIPE DIAMETERS ARE IN INCHES

**CITY OF WALTHAM - SUMP PUMP AMNESTY PROGRAM**  
**CONTRACT 2 - AREAS 5B, 5D & 15**  
**48, 52 & 53 LAKEVIEW TERRACE**

1 inch = 25 feet

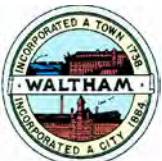



NOTE: ALL PIPE DIAMETERS ARE IN INCHES

**Legend**

- Infiltration Basin
- Sump Pump
- - - Proposed Piping Inside
- Proposed Piping Outside
- Sewer Structures
- Drain Structures
- Drain Lines
- Water Structures
- Water Lines
- Sewer Ties
- Water Ties
- Other Ties
- Contour
- Fences
- Pools



**CITY OF WALTHAM - SUMP PUMP AMNESTY PROGRAM  
 CONTRACT 2 - AREAS 5B, 5D & 15  
 59 & 60 LAKEVIEW TERRACE**

1 inch = 25 feet



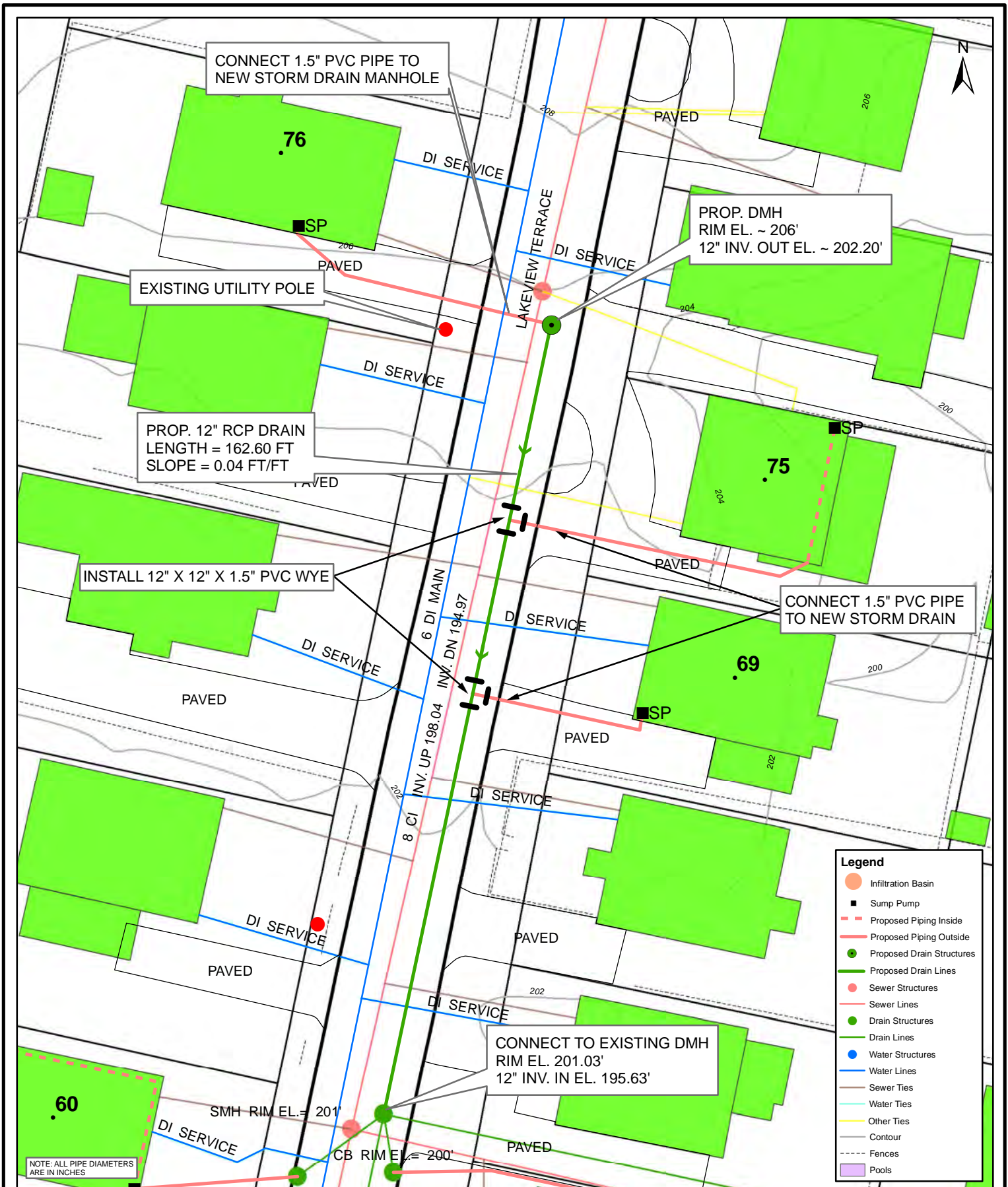

1 inch = 25 feet

**CITY OF WALTHAM - SUMP PUMP AMNESTY PROGRAM  
CONTRACT 2 - AREAS 5B, 5D & 15  
69, 75 & 76 LAKEVIEW TERRACE**



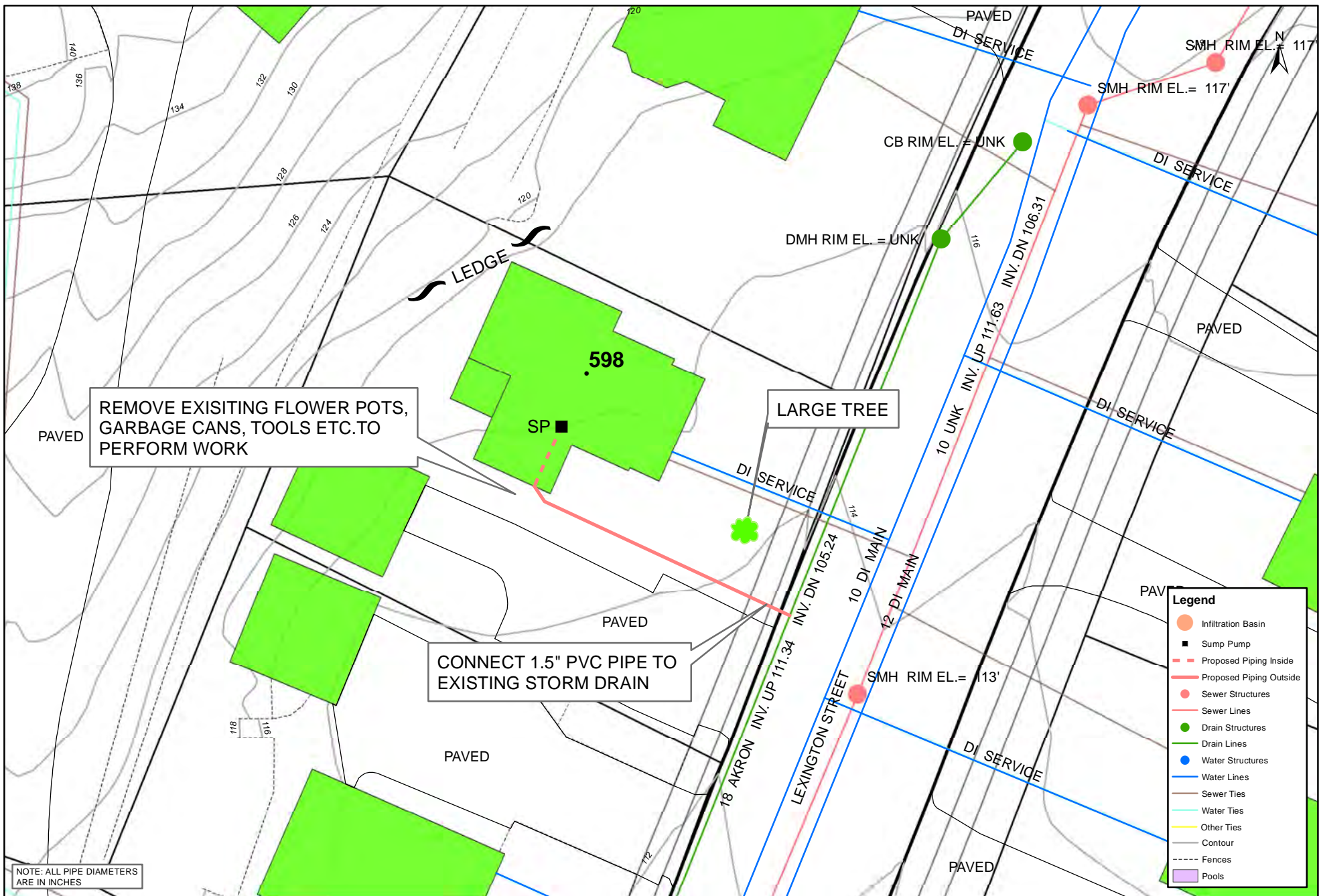

**CITY OF WALTHAM - SUMP PUMP AMNESTY PROGRAM**  
**CONTRACT 2 - AREAS 5B, 5D & 15**  
**598 LEXINGTON STREET**

1 inch = 25 feet

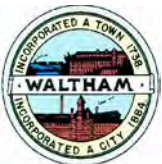



NOTE: ALL PIPE DIAMETERS ARE IN INCHES

**Legend**

- Infiltration Basin
- Sump Pump
- Proposed Piping Inside
- Proposed Piping Outside
- Sewer Structures
- Drain Structures
- Drain Lines
- Water Structures
- Water Lines
- Sewer Ties
- Water Ties
- Other Ties
- Contour
- Fences
- Pools



**CITY OF WALTHAM - SUMP PUMP AMNESTY PROGRAM**  
**CONTRACT 2 - AREAS 5B, 5D & 15**  
**468 LINCOLN STREET**

1 inch = 25 feet





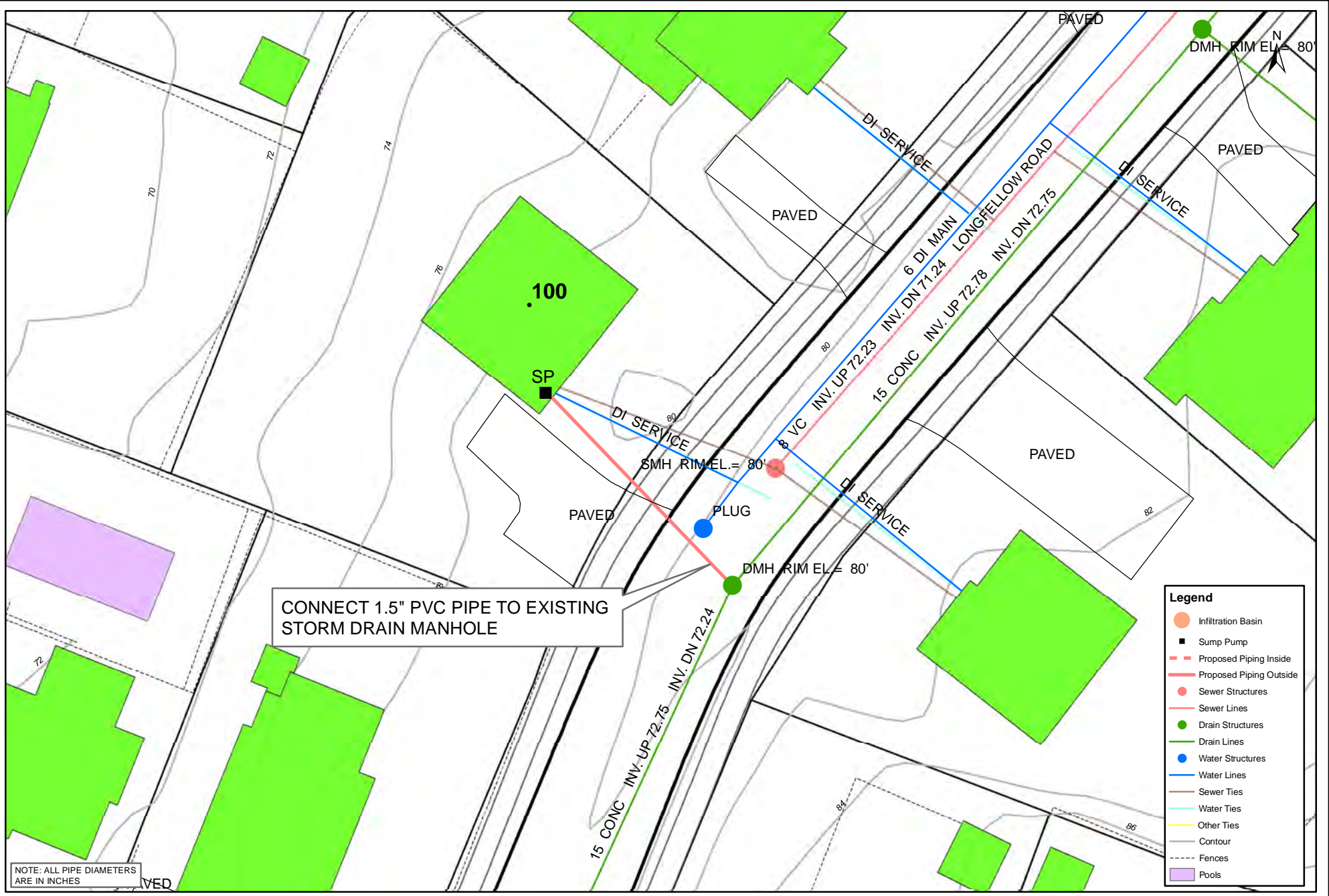

NOTE: ALL PIPE DIAMETERS ARE IN INCHES

Legend	
	Infiltration Basin
	Sump Pump
	Proposed Piping Inside
	Proposed Piping Outside
	Sewer Structures
	Sewer Lines
	Drain Structures
	Drain Lines
	Water Structures
	Water Lines
	Sewer Ties
	Water Ties
	Other Ties
	Contour
	Fences
	Pools

**CITY OF WALTHAM - SUMP PUMP AMNESTY PROGRAM**  
**CONTRACT 2 - AREAS 5B, 5D & 15**  
**100 LONGFELLOW ROAD**

1 inch = 25 feet

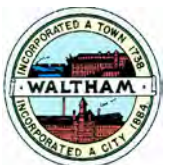

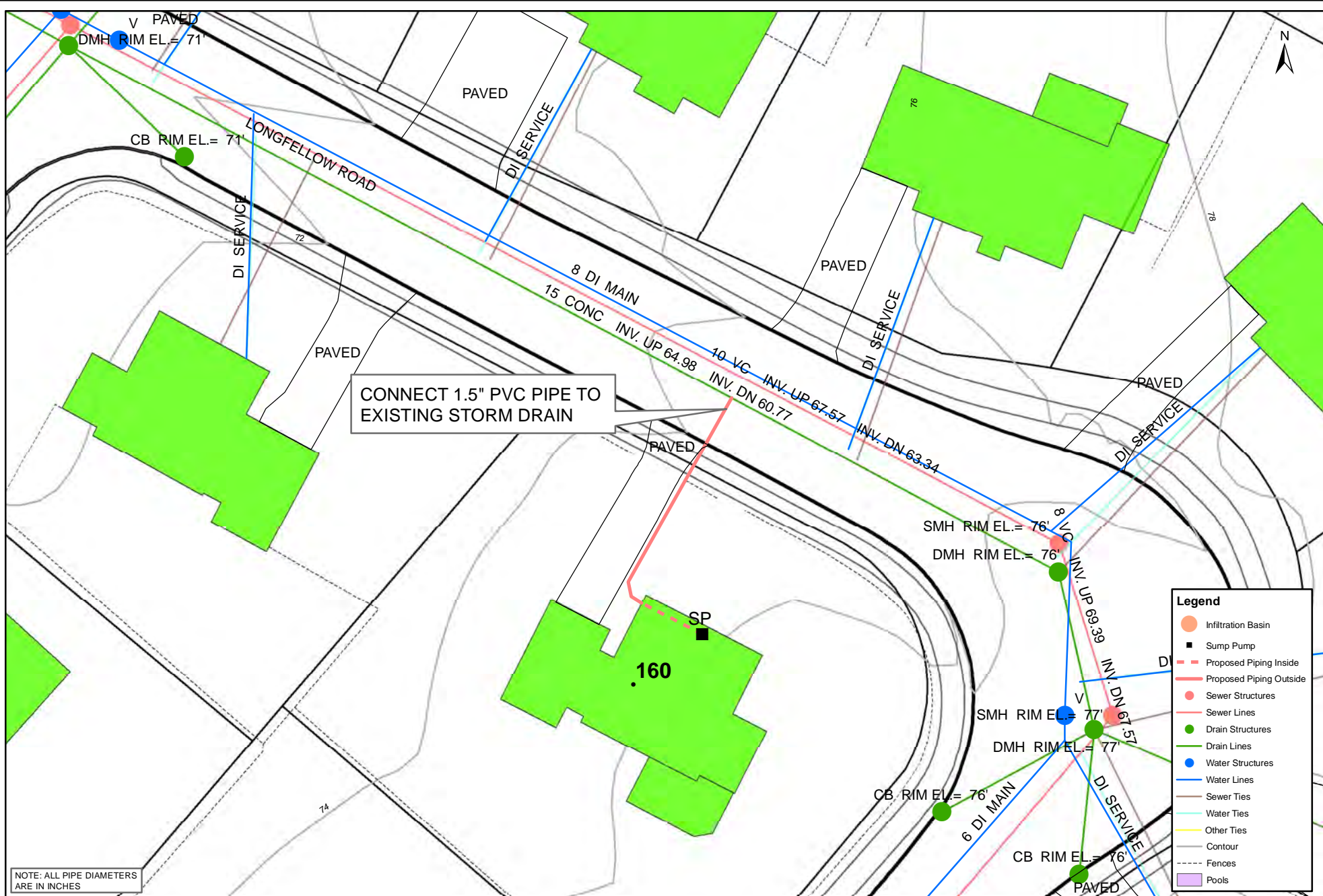

NOTE: ALL PIPE DIAMETERS ARE IN INCHES

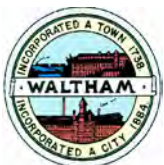

## CITY OF WALTHAM - SUMP PUMP AMNESTY PROGRAM CONTRACT 2 - AREAS 5B, 5D & 15 160 LONGFELLOW ROAD

1 inch = 25 feet



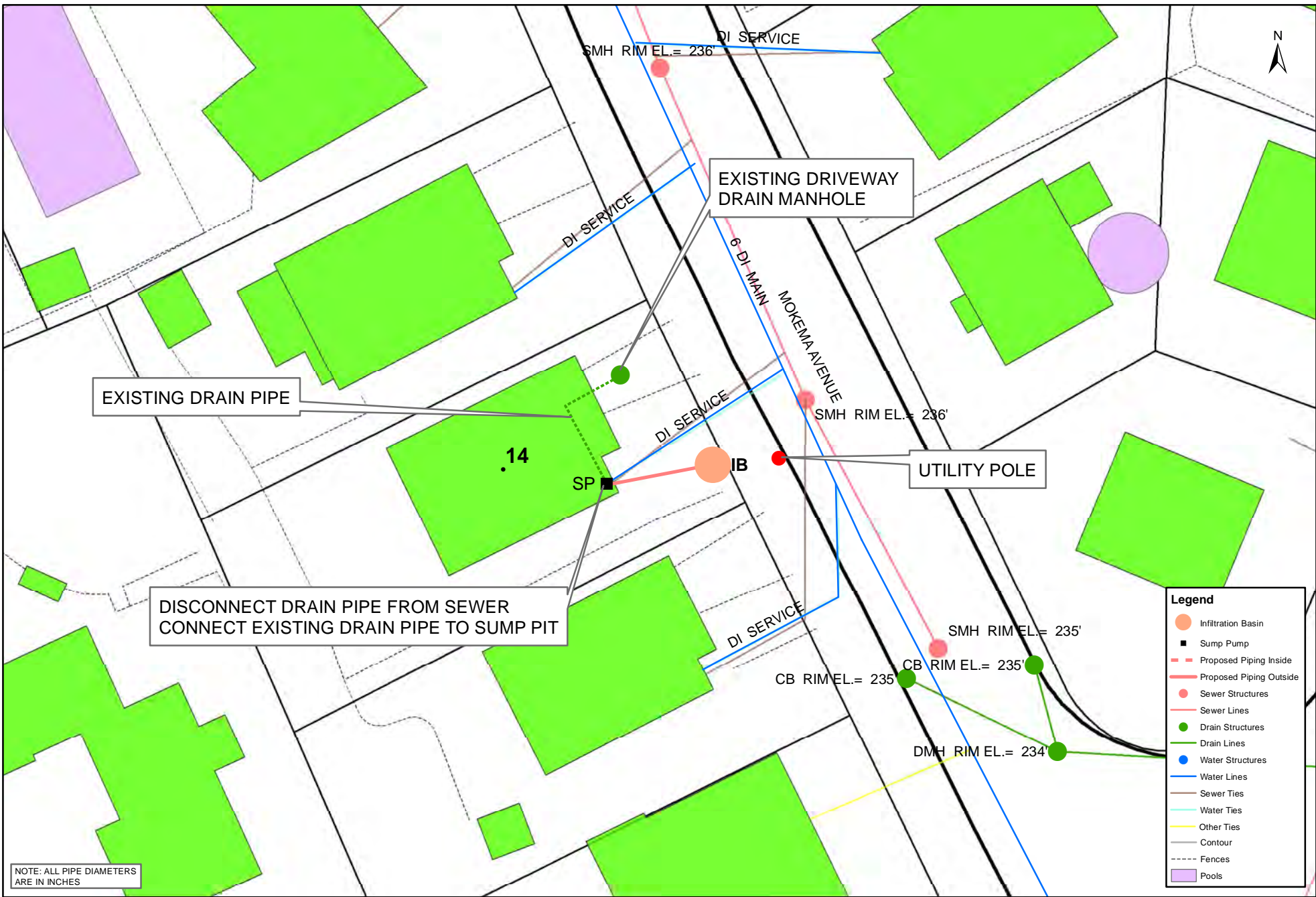

NOTE: ALL PIPE DIAMETERS ARE IN INCHES

**Legend**

- Infiltration Basin
- Sump Pump
- Proposed Piping Inside
- Proposed Piping Outside
- Sewer Structures
- Drain Structures
- Drain Lines
- Water Structures
- Water Lines
- Sewer Ties
- Water Ties
- Other Ties
- Contour
- Fences
- ▭ Pools

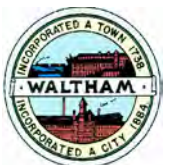

**CITY OF WALTHAM - SUMP PUMP AMNESTY PROGRAM  
 CONTRACT 2 - AREAS 5B, 5D & 15  
 14 MOKEMA AVAENUE**

1 inch = 25 feet





**CITY OF WALTHAM - SUMP PUMP AMNESTY PROGRAM**  
**CONTRACT 2 - AREAS 5B, 5D & 15**  
**47 MOKEMA AVENUE**

1 inch = 25 feet

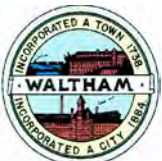



NOTE: ALL PIPE DIAMETERS ARE IN INCHES

Legend	
	Infiltration Basin
	Sump Pump
	Proposed Piping Inside
	Proposed Piping Outside
	Sewer Structures
	Sewer Lines
	Drain Structures
	Drain Lines
	Water Structures
	Water Lines
	Sewer Ties
	Water Ties
	Other Ties
	Contour
	Fences
	Pools

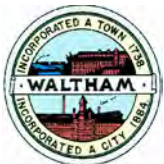

**CITY OF WALTHAM - SUMP PUMP AMNESTY PROGRAM**  
**CONTRACT 2 - AREAS 5B, 5D & 15**  
**107 MOKEMA AVENUE**

1 inch = 25 feet



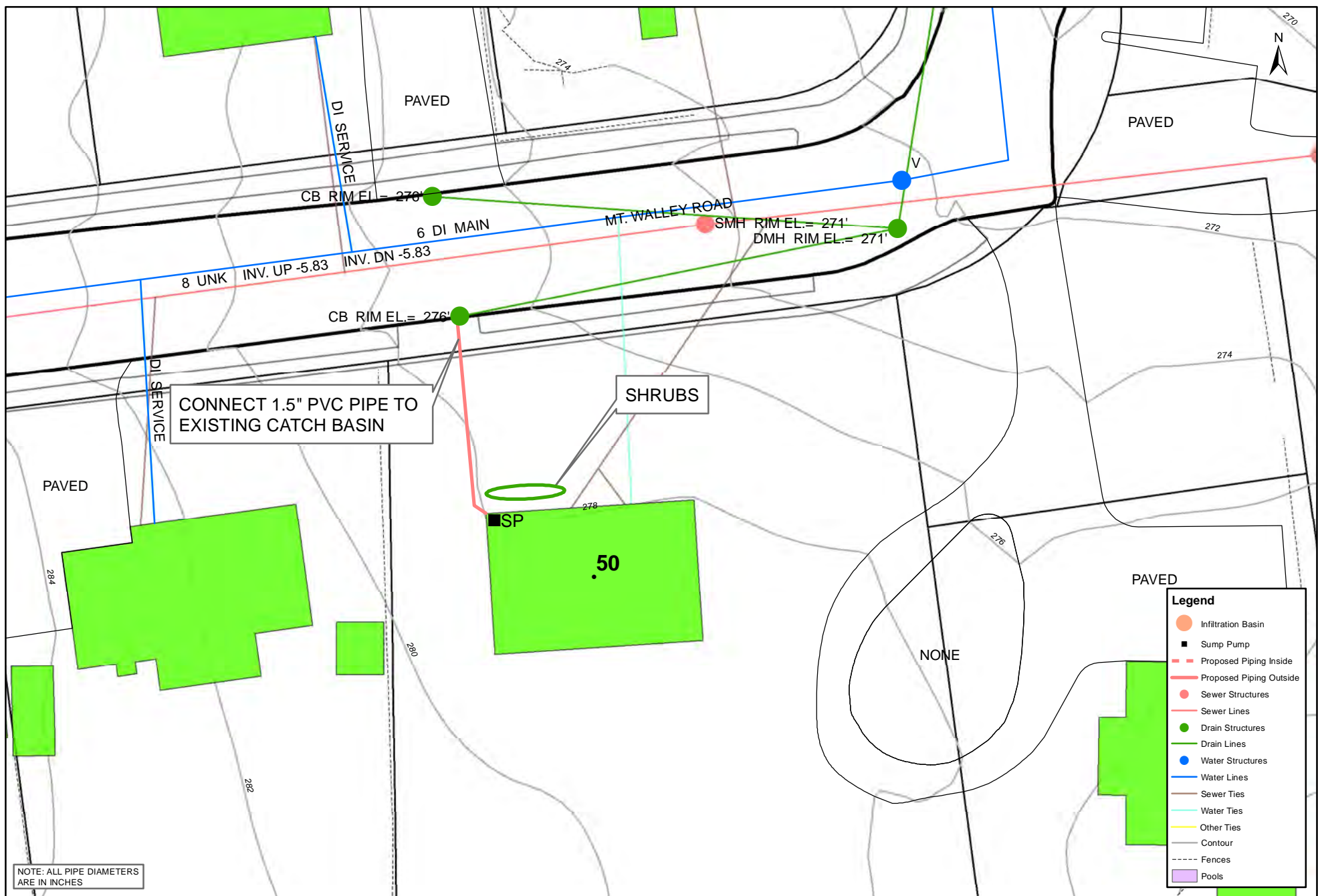

NOTE: ALL PIPE DIAMETERS ARE IN INCHES

**CITY OF WALTHAM - SUMP PUMP AMNESTY PROGRAM**  
**CONTRACT 2 - AREAS 5B, 5D & 15**  
**50 MOUNT WALLEY ROAD**

1 inch = 25 feet



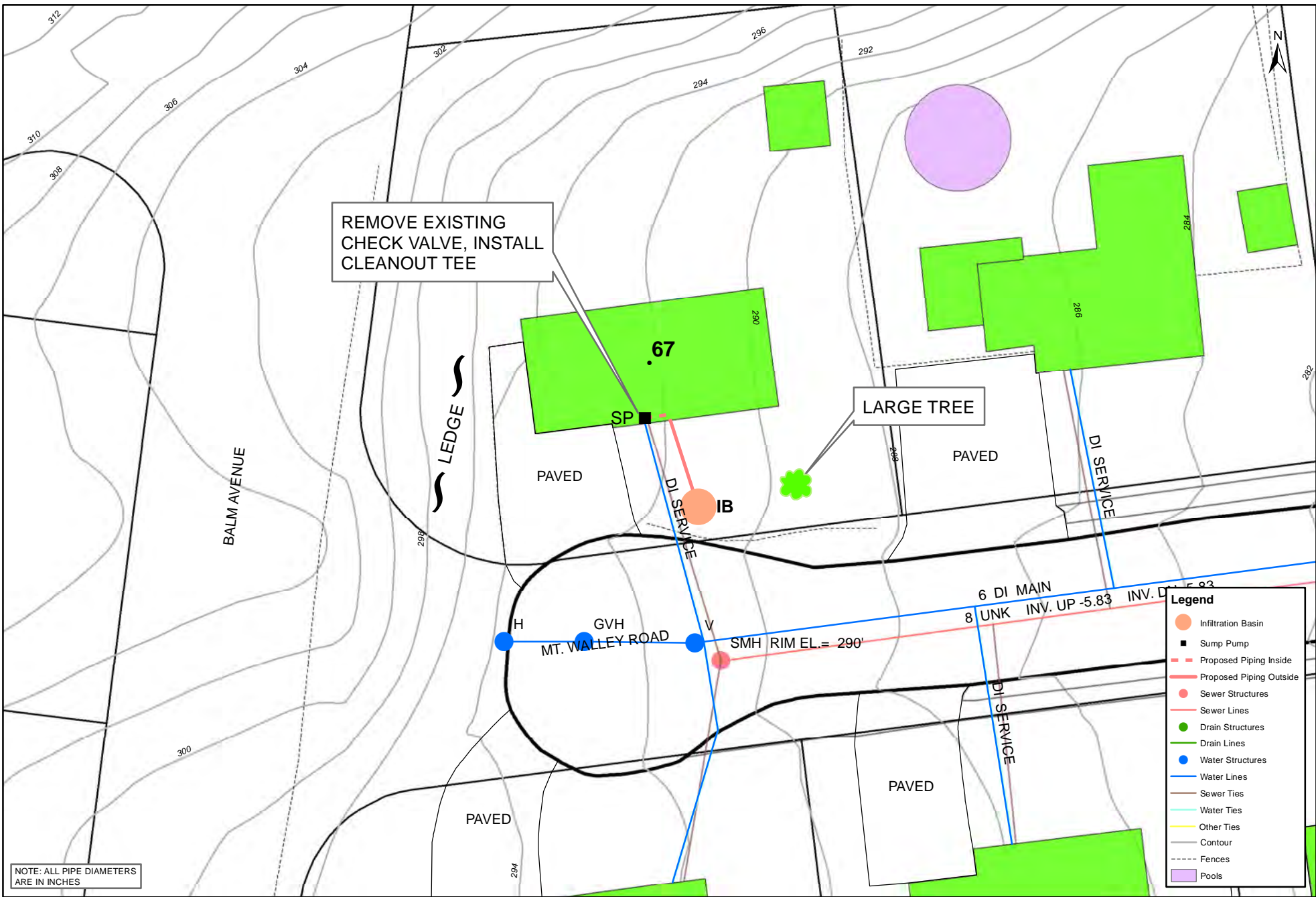

NOTE: ALL PIPE DIAMETERS ARE IN INCHES

**CITY OF WALTHAM - SUMP PUMP AMNESTY PROGRAM**  
**CONTRACT 2 - AREAS 5B, 5D & 15**  
**67 MOUNT WALLEY ROAD**

1 inch = 25 feet

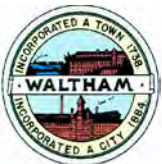



NOTE: ALL PIPE DIAMETERS ARE IN INCHES

Legend	
	Infiltration Basin
	Sump Pump
	Proposed Piping Inside
	Proposed Piping Outside
	Sewer Structures
	Drain Structures
	Drain Lines
	Water Structures
	Water Lines
	Sewer Ties
	Water Ties
	Other Ties
	Contour
	Fences
	Pools



**CITY OF WALTHAM - SUMP PUMP AMNESTY PROGRAM**  
**CONTRACT 2 - AREAS 5B, 5D & 15**  
**11 NUTTING ROAD**

1 inch = 25 feet







**CITY OF WALTHAM - SUMP PUMP AMNESTY PROGRAM**  
**CONTRACT 2 - AREAS 5B, 5D & 15**  
**43 OVERLOOK ROAD**

1 inch = 25 feet

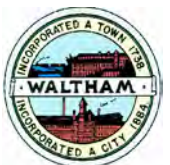



**CITY OF WALTHAM - SUMP PUMP AMNESTY PROGRAM**  
**CONTRACT 2 - AREAS 5B, 5D & 15**  
**88 & 95 PRINCETON AVENUE**

1 inch = 25 feet

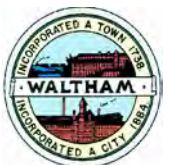



**CITY OF WALTHAM - SUMP PUMP AMNESTY PROGRAM**  
**CONTRACT 2 - AREAS 5B, 5D & 15**  
**98, 104 & 105 PRINCETON AVENUE**

1 inch = 25 feet

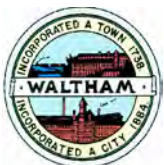

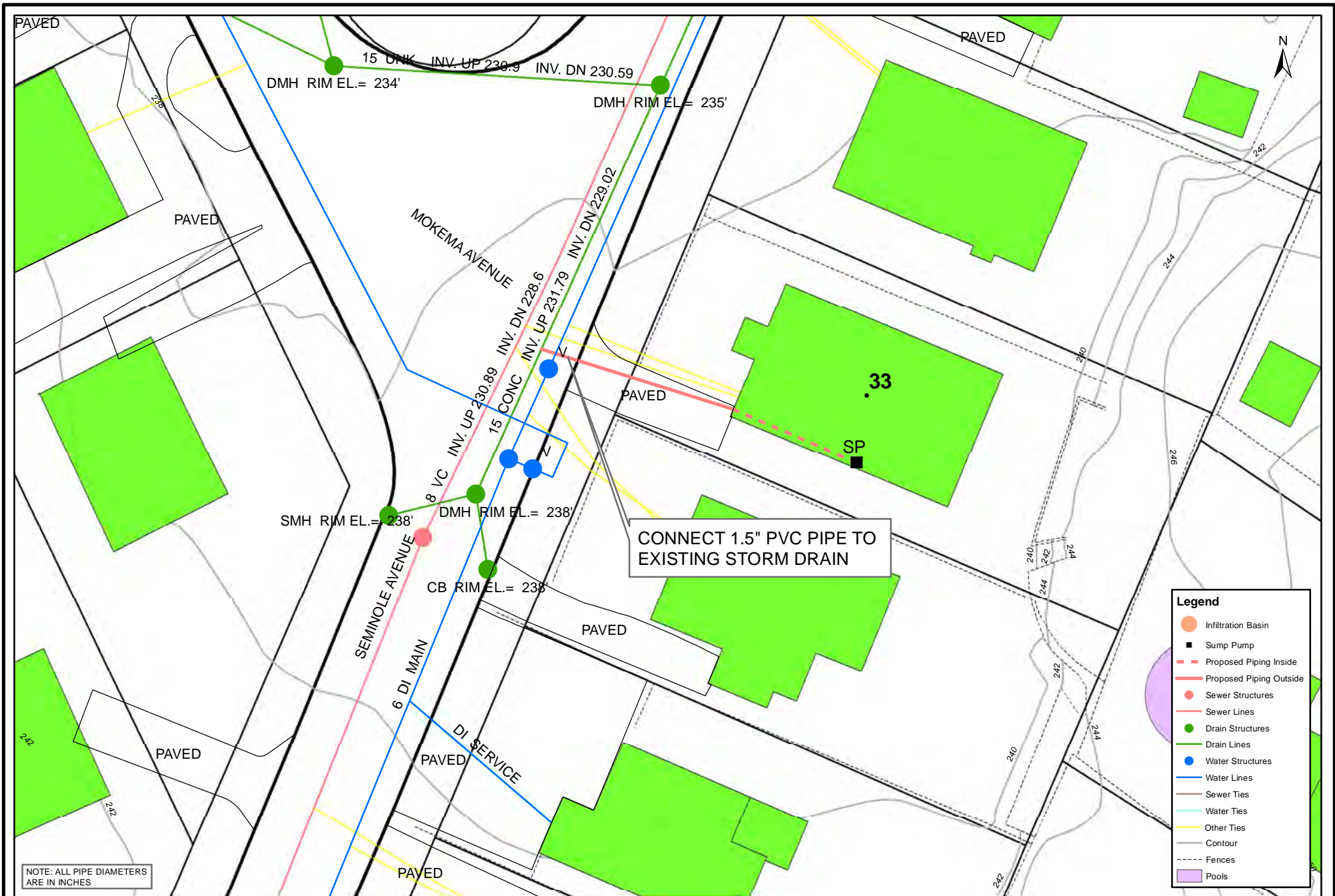

CONNECT 1.5" PVC PIPE TO EXISTING STORM DRAIN

Legend	
	Infiltration Basin
	Sump Pump
	Proposed Piping Inside
	Proposed Piping Outside
	Sewer Structures
	Sewer Lines
	Drain Structures
	Drain Lines
	Water Structures
	Water Lines
	Sewer Ties
	Water Ties
	Other Ties
	Contours
	Fences
	Pools

NOTE: ALL PIPE DIAMETERS ARE IN INCHES

**CITY OF WALTHAM - SUMP PUMP AMNESTY PROGRAM**  
**CONTRACT 2 - AREAS 5B, 5D & 15**  
**33 SEMINOLE AVENUE**

1 inch = 25 feet

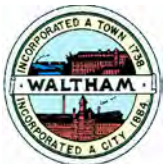



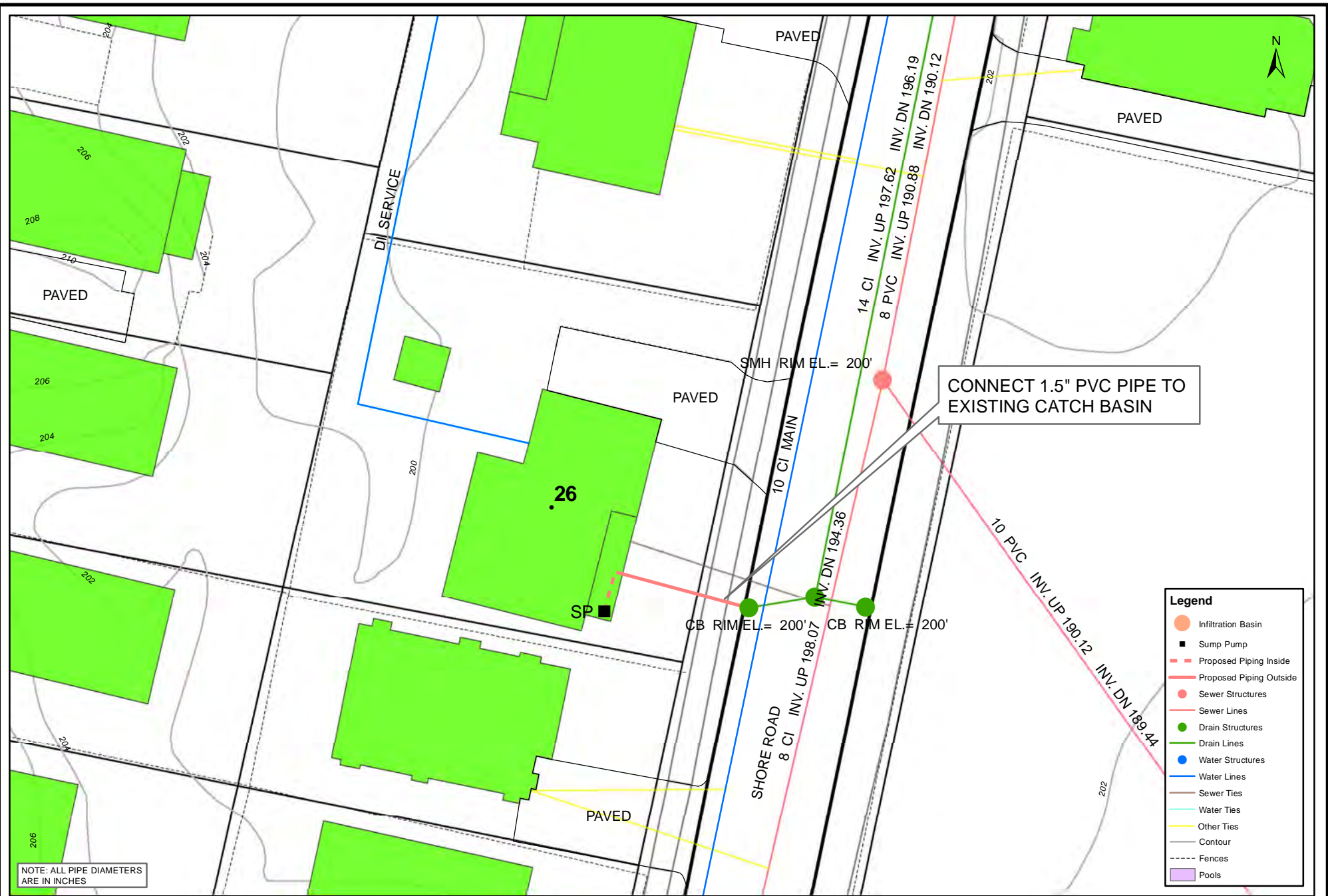

NOTE: ALL PIPE DIAMETERS ARE IN INCHES

Legend	
	Infiltration Basin
	Sump Pump
	Proposed Piping Inside
	Proposed Piping Outside
	Sewer Structures
	Sewer Lines
	Drain Structures
	Drain Lines
	Water Structures
	Water Lines
	Sewer Ties
	Water Ties
	Other Ties
	Contour
	Fences
	Pools

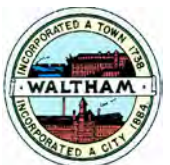

**CITY OF WALTHAM - SUMP PUMP AMNESTY PROGRAM**  
**CONTRACT 2 - AREAS 5B, 5D & 15**  
**26 SHORE ROAD**

1 inch = 25 feet



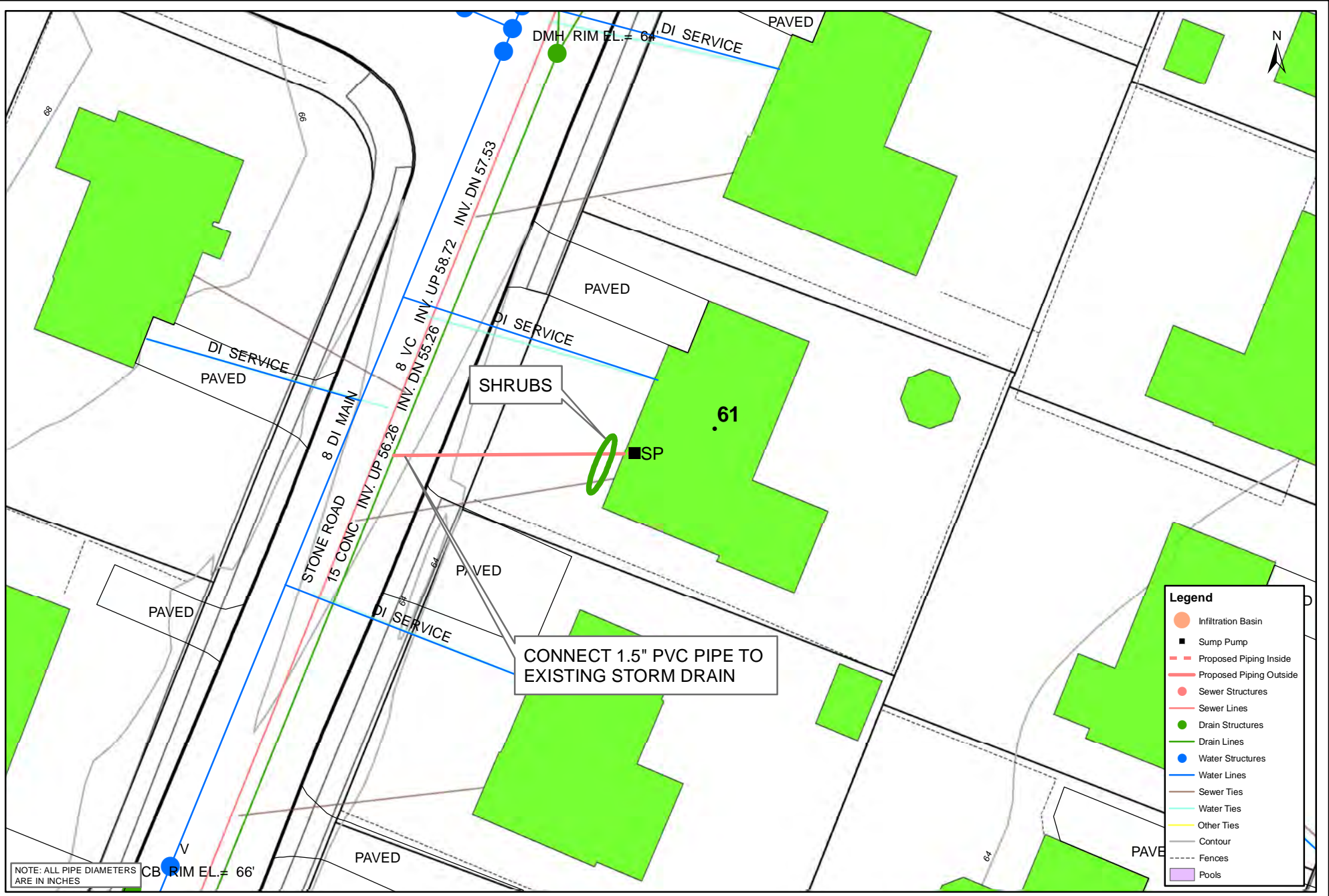

NOTE: ALL PIPE DIAMETERS ARE IN INCHES

Legend	
	Infiltration Basin
	Sump Pump
	Proposed Piping Inside
	Proposed Piping Outside
	Sewer Structures
	Sewer Lines
	Drain Structures
	Drain Lines
	Water Structures
	Water Lines
	Sewer Ties
	Water Ties
	Other Ties
	Contour
	Fences
	Pools

**CITY OF WALTHAM - SUMP PUMP AMNESTY PROGRAM**  
**CONTRACT 2 - AREAS 5B, 5D & 15**  
**61 STONE ROAD**

1 inch = 25 feet

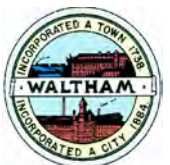



NOTE: ALL PIPE DIAMETERS ARE IN INCHES

Legend	
	Infiltration Basin
	Sump Pump
	Proposed Piping Inside
	Proposed Piping Outside
	Sewer Structures
	Sewer Lines
	Drain Structures
	Drain Lines
	Water Structures
	Water Lines
	Sewer Ties
	Water Ties
	Other Ties
	Contour
	Fences
	Pools

**CITY OF WALTHAM - SUMP PUMP AMNESTY PROGRAM**  
**CONTRACT 2 - AREAS 5B, 5D & 15**  
**71 STONE ROAD**

1 inch = 25 feet

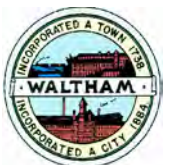





**CITY OF WALTHAM - SUMP PUMP AMNESTY PROGRAM**  
**CONTRACT 2 - AREAS 5B, 5D & 15**  
**88 TRIMOUNT AVAENUE**

1 inch = 25 feet

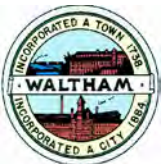



**CITY OF WALTHAM - SUMP PUMP AMNESTY PROGRAM**  
**CONTRACT 2 - AREAS 5B, 5D & 15**  
**101 TRIMOUNT AVAENUE**

1 inch = 25 feet

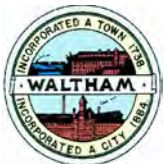

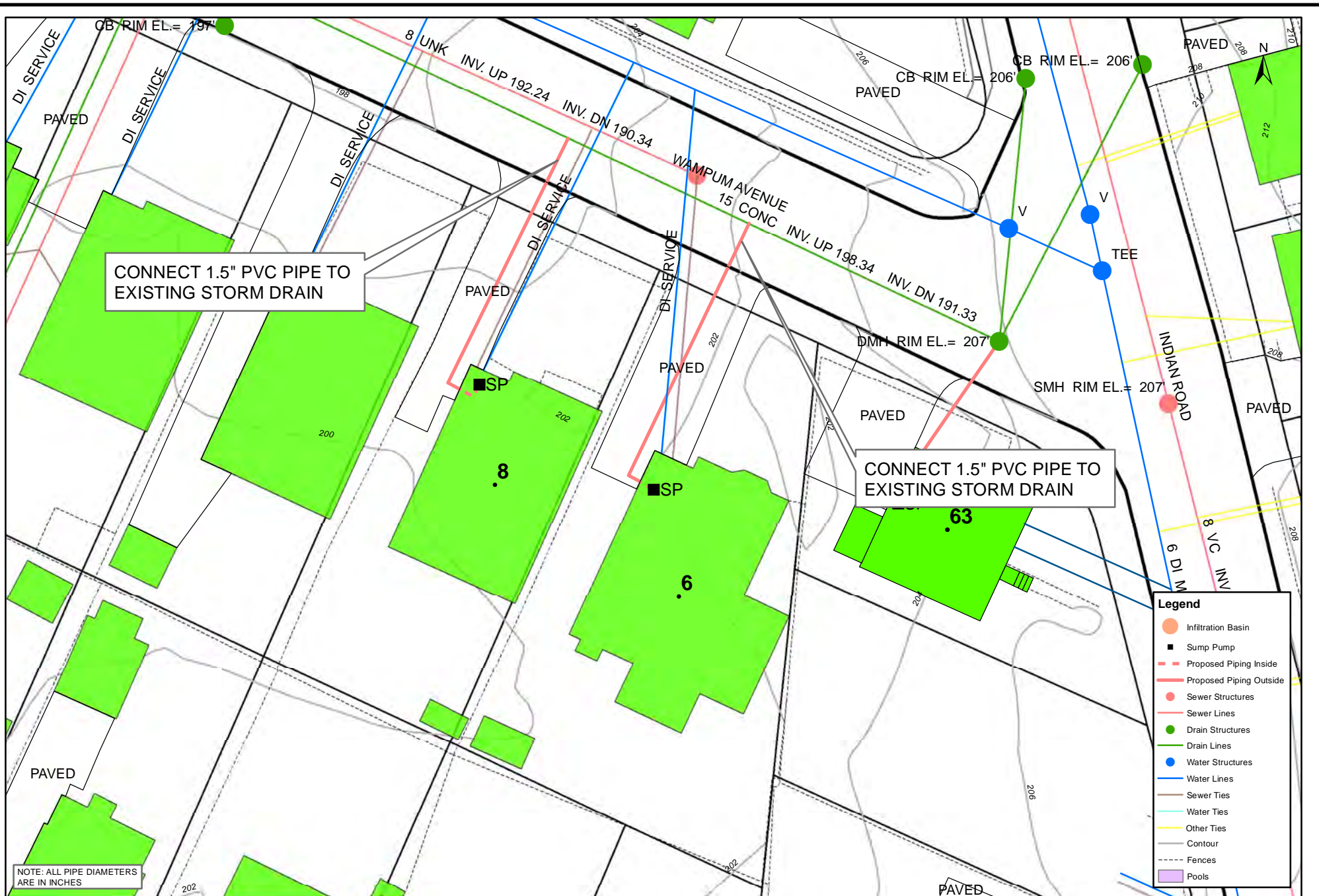

Legend	
	Infiltration Basin
	Sump Pump
	Proposed Piping Inside
	Proposed Piping Outside
	Sewer Structures
	Sewer Lines
	Drain Structures
	Drain Lines
	Water Structures
	Water Lines
	Sewer Ties
	Water Ties
	Other Ties
	Contour
	Fences
	Pools

NOTE: ALL PIPE DIAMETERS ARE IN INCHES

# CITY OF WALTHAM - SUMP PUMP AMNESTY PROGRAM

## CONTRACT 2 - AREAS 5B, 5D & 15

### 6 & 8 WAMPUM AVENUE

1 inch = 25 feet

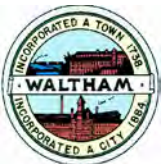

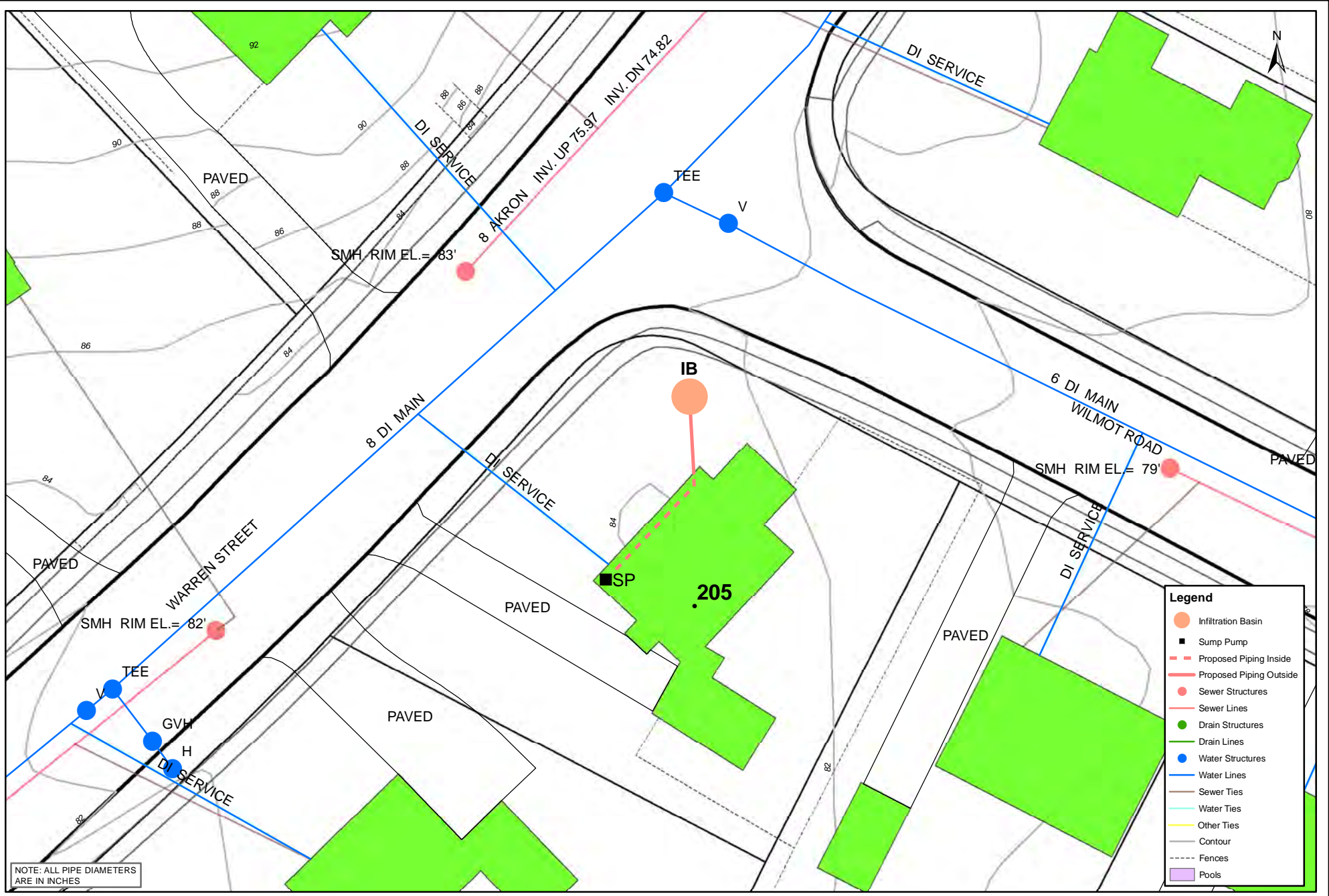

**CITY OF WALTHAM - SUMP PUMP AMNESTY PROGRAM**  
**CONTRACT 2 - AREAS 5B, 5D & 15**  
**205 WARREN STREET**

1 inch = 25 feet

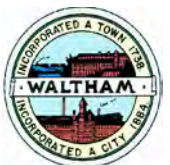

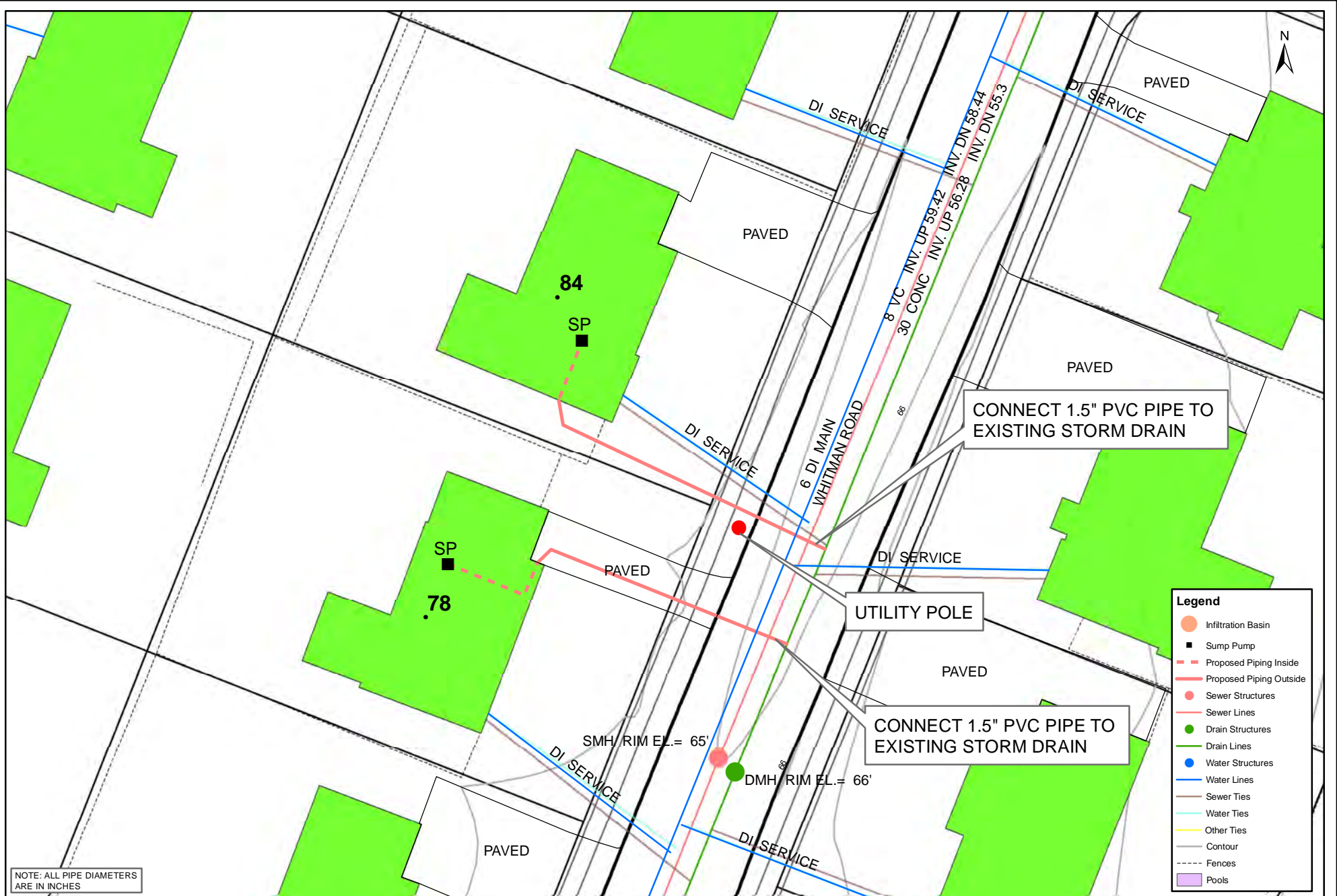

NOTE: ALL PIPE DIAMETERS ARE IN INCHES

Legend	
	Infiltration Basin
	Sump Pump
	Proposed Piping Inside
	Proposed Piping Outside
	Sewer Structures
	Sewer Lines
	Drain Structures
	Drain Lines
	Water Structures
	Water Lines
	Sewer Ties
	Water Ties
	Other Ties
	Contour
	Fences
	Pools

**CITY OF WALTHAM - SUMP PUMP AMNESTY PROGRAM**  
**CONTRACT 2 - AREAS 5B, 5D & 15**  
**78 & 84 WHITMAN ROAD**

1 inch = 25 feet

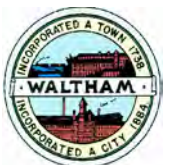

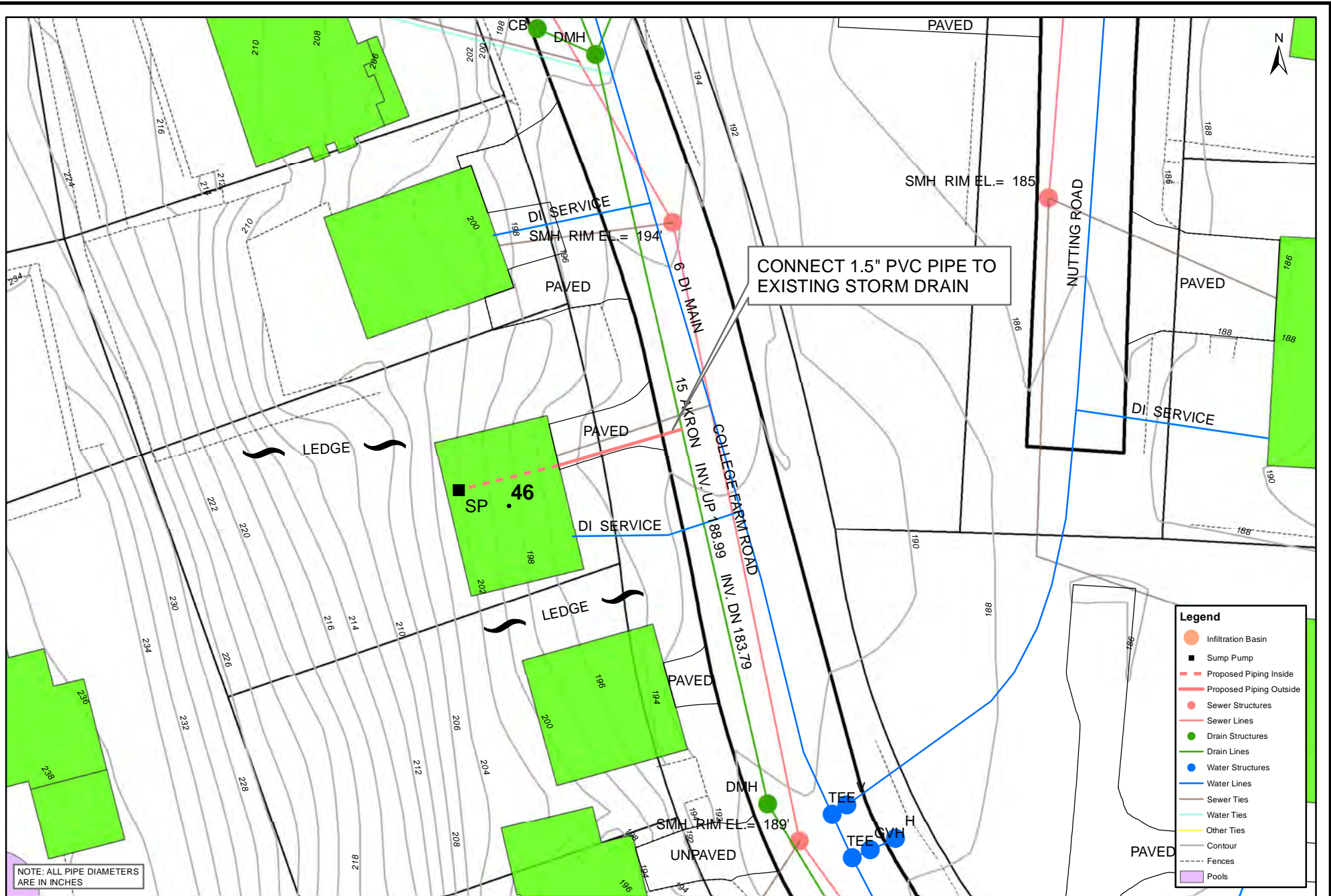

NOTE: ALL PIPE DIAMETERS ARE IN INCHES

Legend	
	Infiltration Basin
	Sump Pump
	Proposed Piping Inside
	Proposed Piping Outside
	Sewer Structures
	Sewer Lines
	Drain Structures
	Drain Lines
	Water Structures
	Water Lines
	Sewer Ties
	Water Ties
	Other Ties
	Contour
	Fences
	Pools

**CITY OF WALTHAM - SUMP PUMP AMNESTY PROGRAM**  
**CONTRACT 2 - AREAS 5B, 5D & 15**  
**46 COLLEGE FARM ROAD**

1 inch = 25 feet

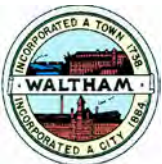

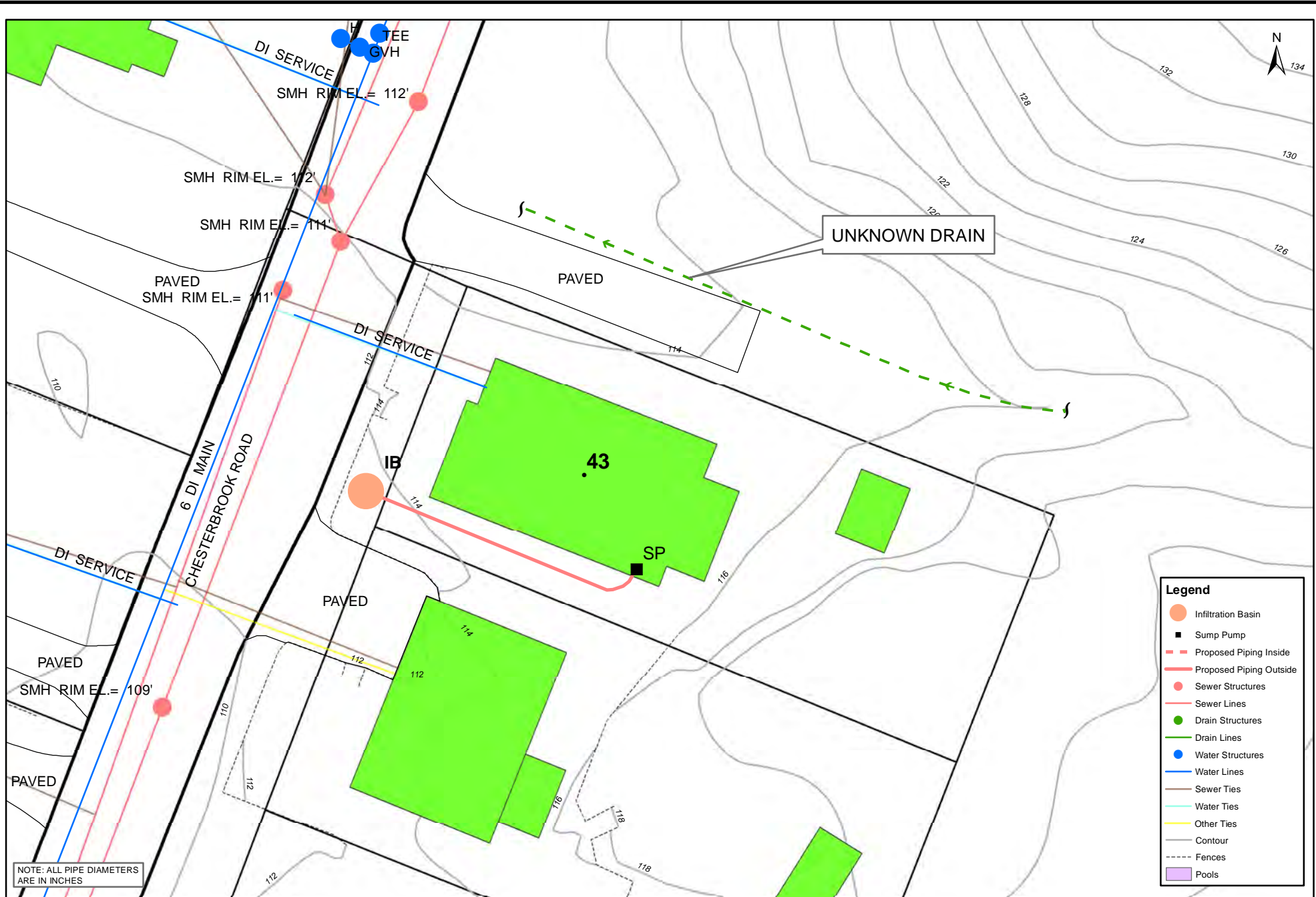

**CITY OF WALTHAM - SUMP PUMP AMNESTY PROGRAM**  
**CONTRACT 2 - AREAS 5B, 5D & 15**  
**43 CHESTERBROOK AVENUE**

1 inch = 25 feet

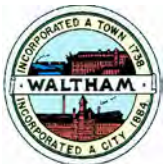

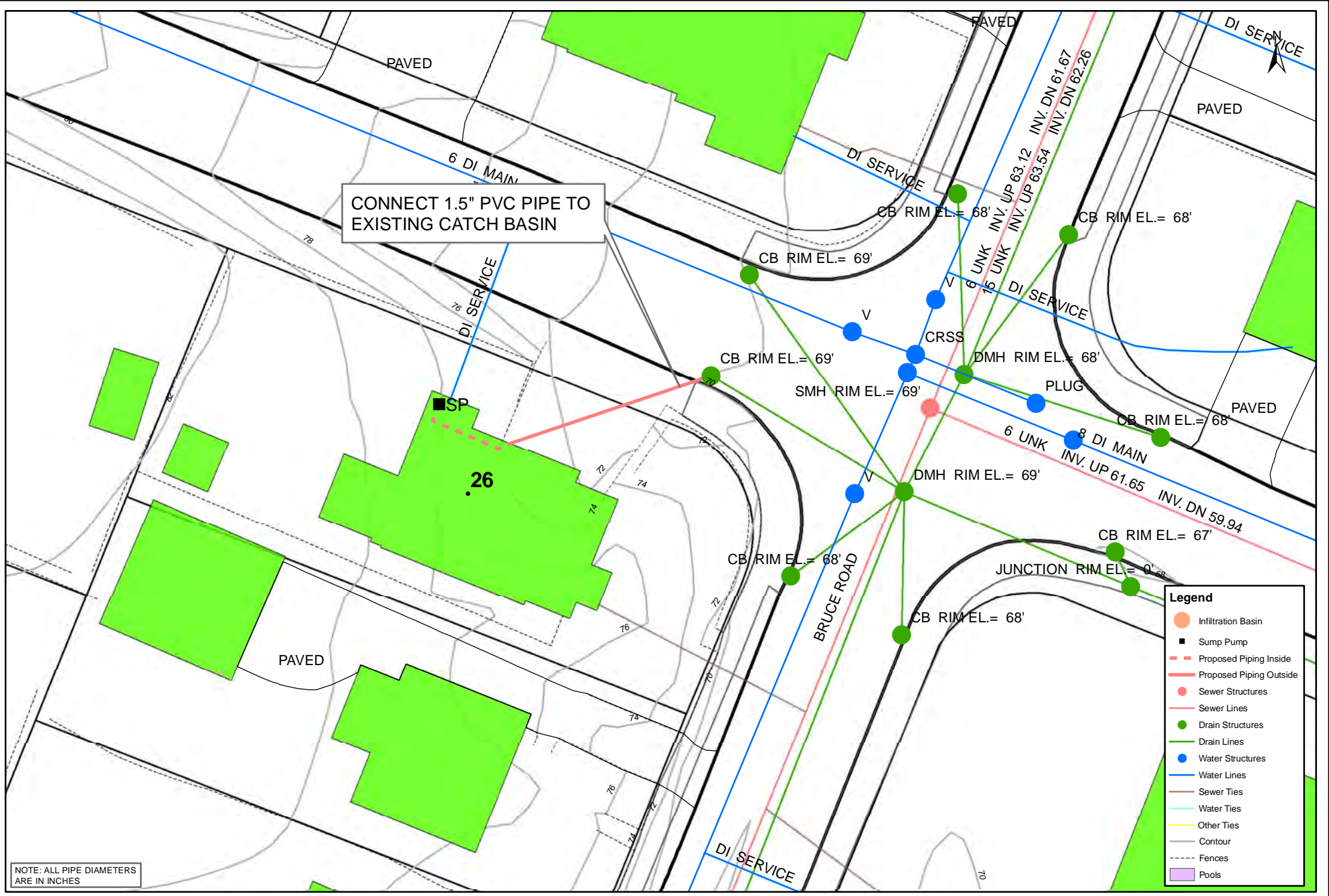

CONNECT 1.5" PVC PIPE TO EXISTING CATCH BASIN

- Legend**
- Infiltration Basin
  - Sump Pump
  - Proposed Piping Inside
  - Proposed Piping Outside
  - Sewer Structures
  - Sewer Lines
  - Drain Structures
  - Drain Lines
  - Water Structures
  - Water Lines
  - Sewer Ties
  - Water Ties
  - Other Ties
  - Contour
  - Fences
  - Pools

NOTE: ALL PIPE DIAMETERS ARE IN INCHES

**CITY OF WALTHAM - SUMP PUMP AMNESTY PROGRAM**  
**CONTRACT 2 - AREAS 5B, 5D & 15**  
**26 BRUCE ROAD**

1 inch = 25 feet

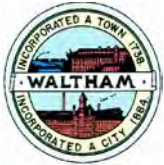



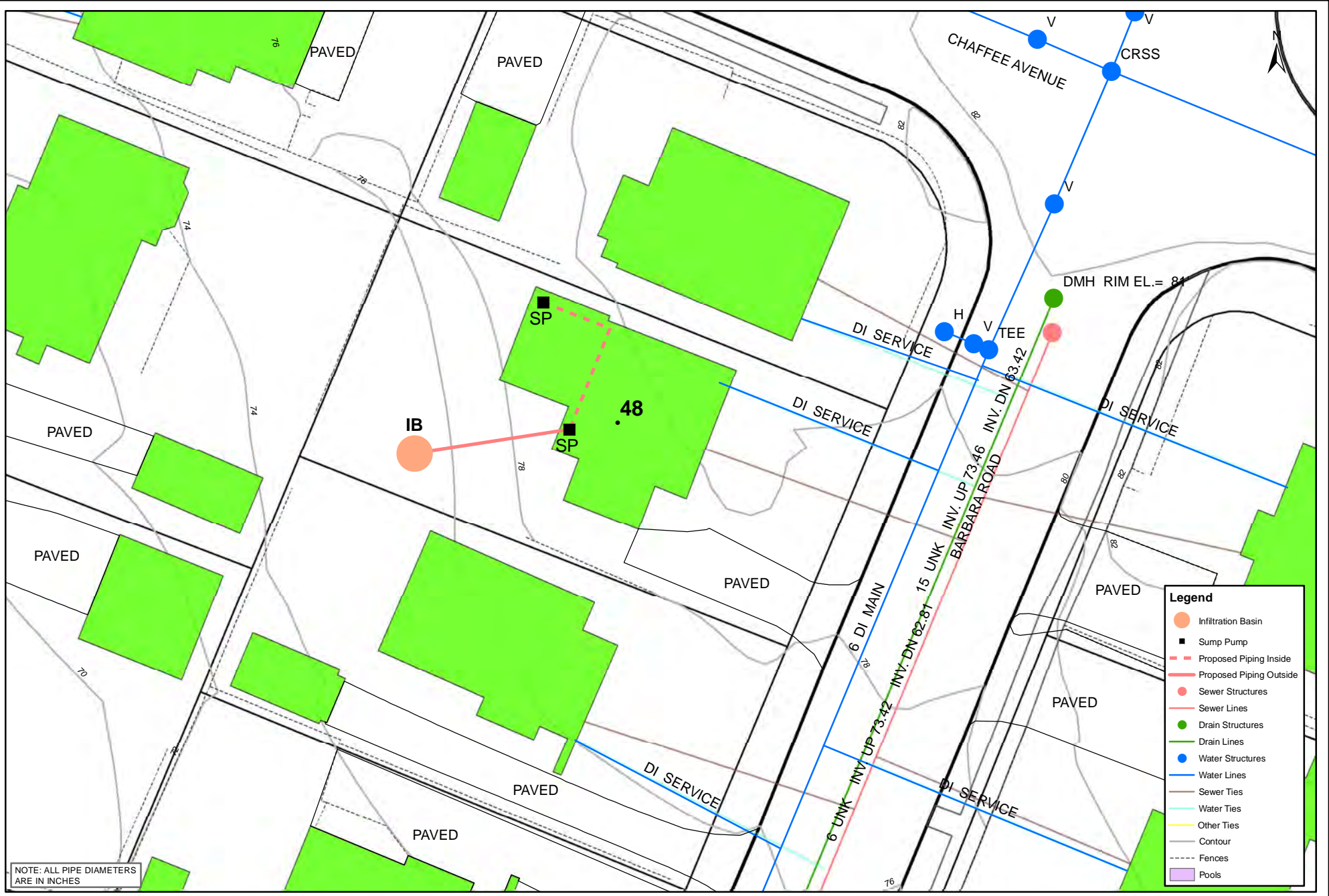

**CITY OF WALTHAM - SUMP PUMP AMNESTY PROGRAM**  
**CONTRACT 2 - AREAS 5B, 5D & 15**  
**48 BARBARA ROAD**

1 inch = 25 feet

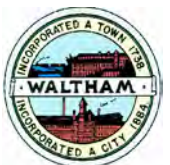



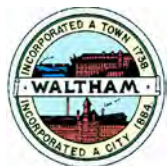

**CITY OF WALTHAM - SUMP PUMP AMNESTY PROGRAM**  
**CONTRACT 2 - AREAS 5B, 5D & 15**  
**50 AMHERST AVENUE**



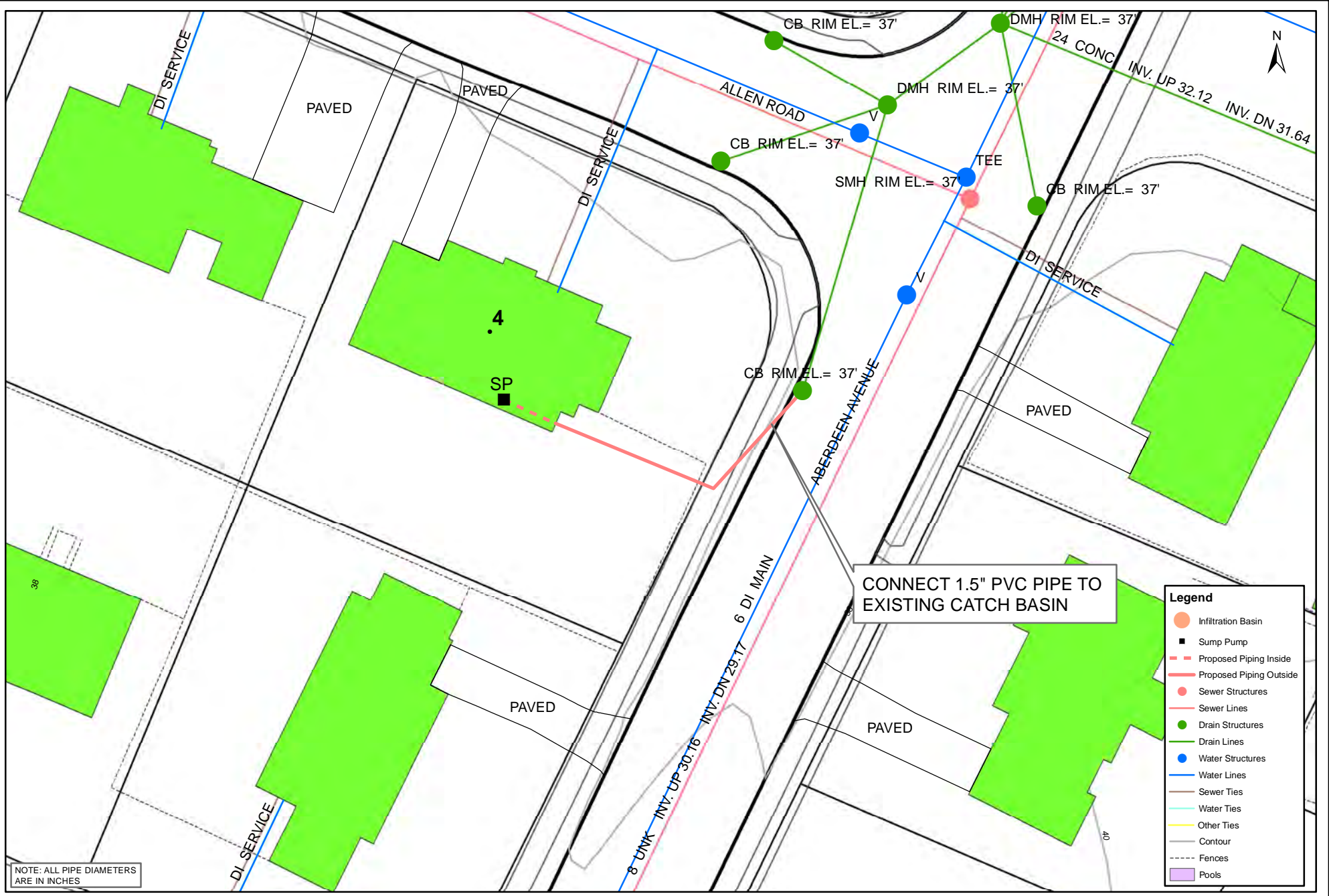

NOTE: ALL PIPE DIAMETERS ARE IN INCHES

CONNECT 1.5" PVC PIPE TO EXISTING CATCH BASIN

Legend	
	Infiltration Basin
	Sump Pump
	Proposed Piping Inside
	Proposed Piping Outside
	Sewer Structures
	Sewer Lines
	Drain Structures
	Drain Lines
	Water Structures
	Water Lines
	Sewer Ties
	Water Ties
	Other Ties
	Contour
	Fences
	Pools

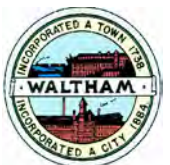

**CITY OF WALTHAM - SUMP PUMP AMNESTY PROGRAM**  
**CONTRACT 2 - AREAS 5B, 5D & 15**  
**4 ALLEN ROAD**

1 inch = 25 feet



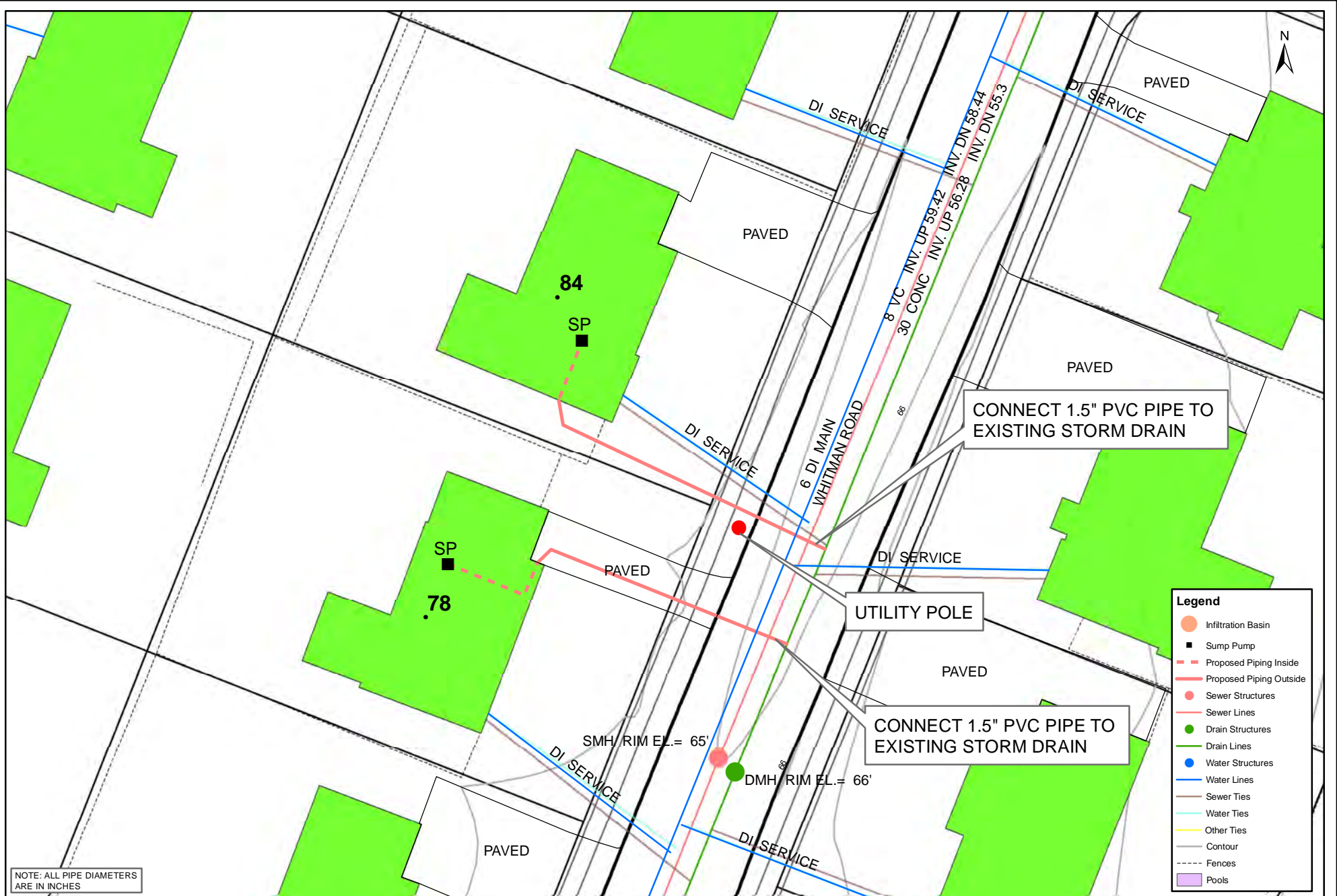

NOTE: ALL PIPE DIAMETERS ARE IN INCHES

Legend	
	Infiltration Basin
	Sump Pump
	Proposed Piping Inside
	Proposed Piping Outside
	Sewer Structures
	Sewer Lines
	Drain Structures
	Drain Lines
	Water Structures
	Water Lines
	Sewer Ties
	Water Ties
	Other Ties
	Contour
	Fences
	Pools

**CITY OF WALTHAM - SUMP PUMP AMNESTY PROGRAM**  
**CONTRACT 2 - AREAS 5B, 5D & 15**  
**78 & 84 WHITMAN ROAD**

1 inch = 25 feet

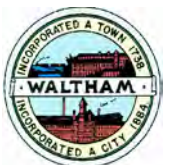

## **Appendix “B” – Details**

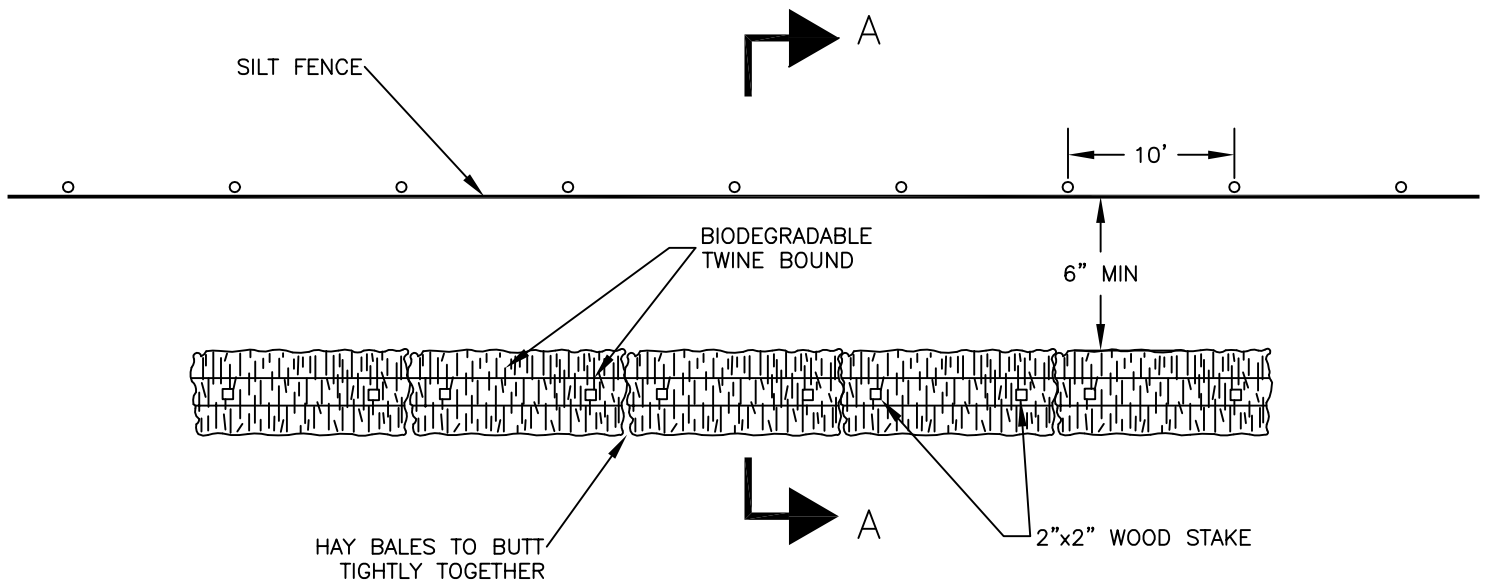

EROSION BARRIER  
HAY BALES AND SILT FENCE PLAN

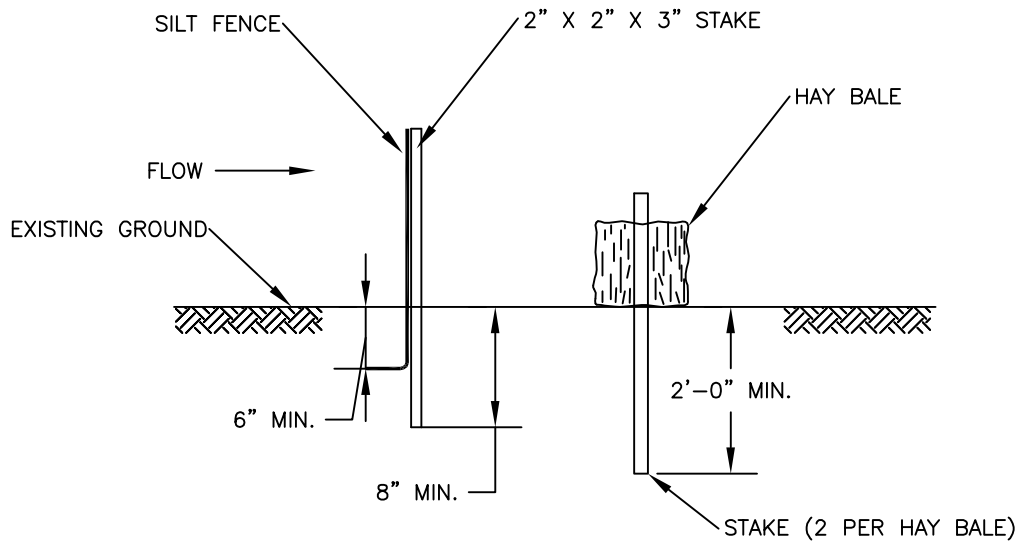

SECTION A-A

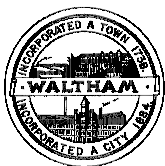
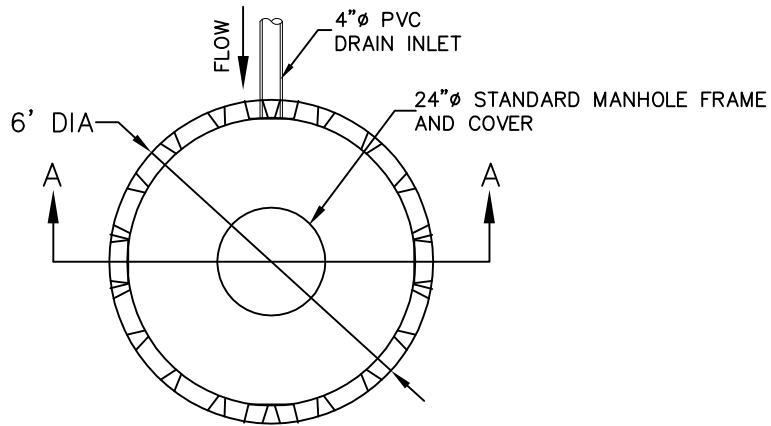

FIGURE NAME:  
199.000.A – HAY BALE FOR EROSION CONTROL

CITY OF WALTHAM, MA. – ENGINEERING DEPARTMENT  
STANDARD DETAILS

SCALE:  
NOT TO SCALE

REV. DATE:  
12/8/2010 335



PLAN VIEW

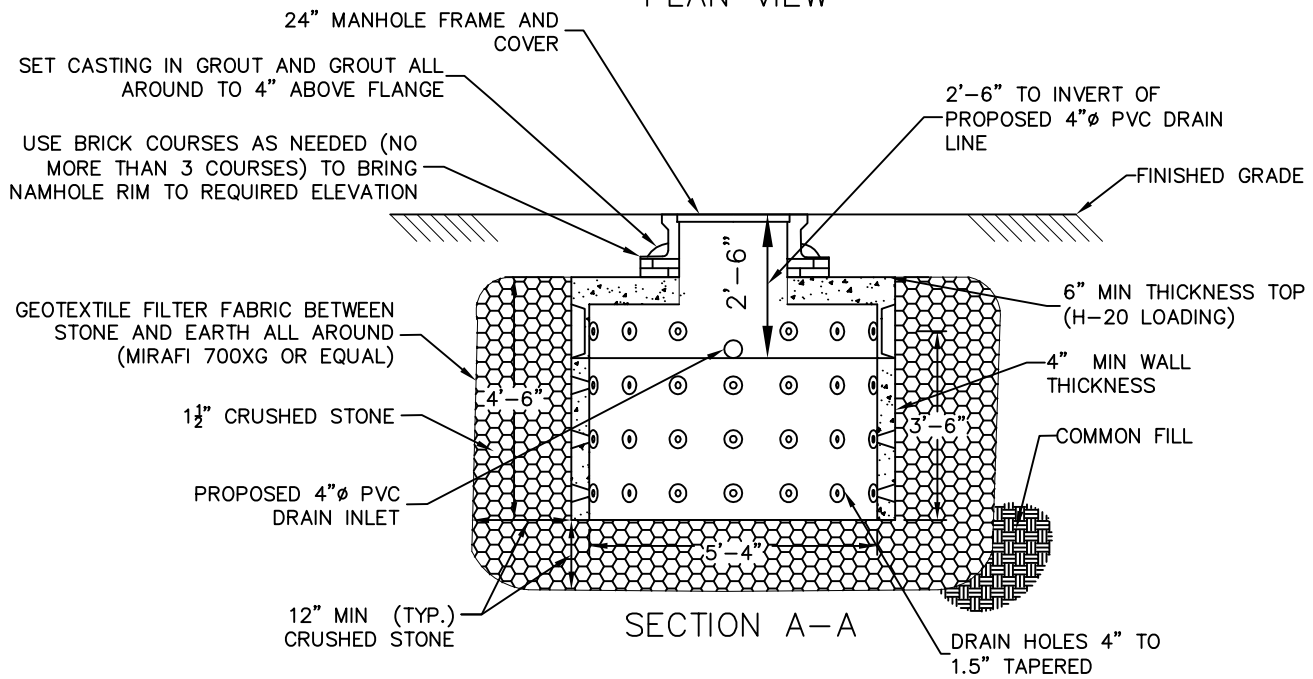

SECTION A-A

6' Ø CYLINDRICAL INFILTRATION BASIN

NOT TO SCALE

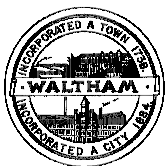

FIGURE NAME:

201.999 - 6' DIAMETER INFILTRATION BASIN

CITY OF WALTHAM, MA. - ENGINEERING DEPARTMENT  
STANDARD DETAILS

SCALE:

NOT TO SCALE

REV. DATE:

10/7/2010

336



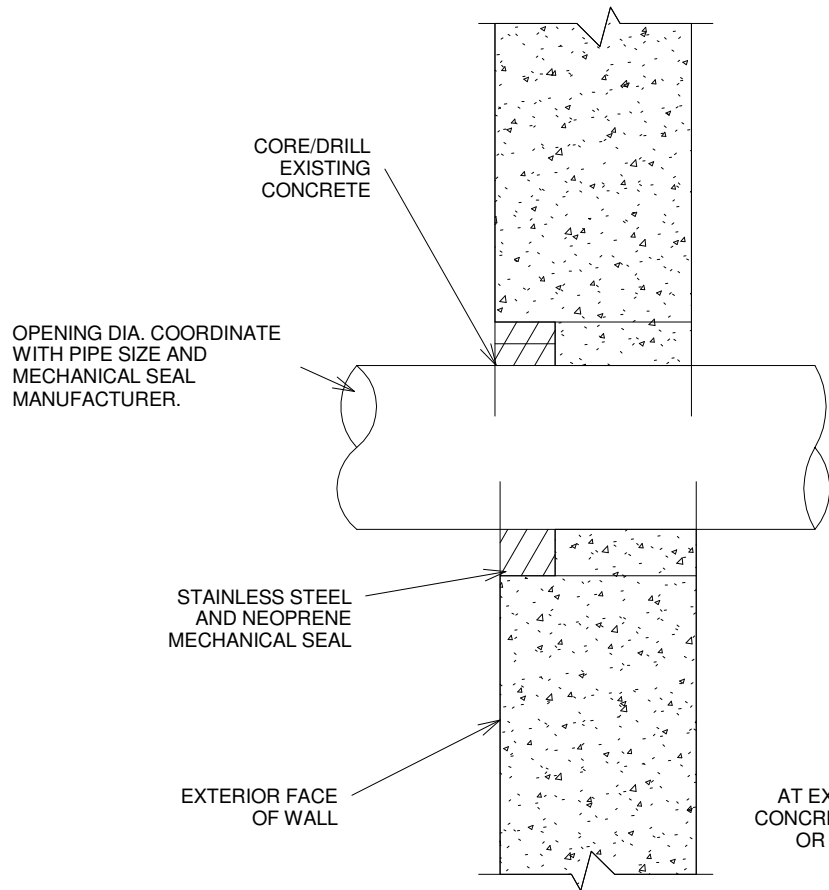

AT EXISTING  
CONCRETE WALL  
OR SLAB

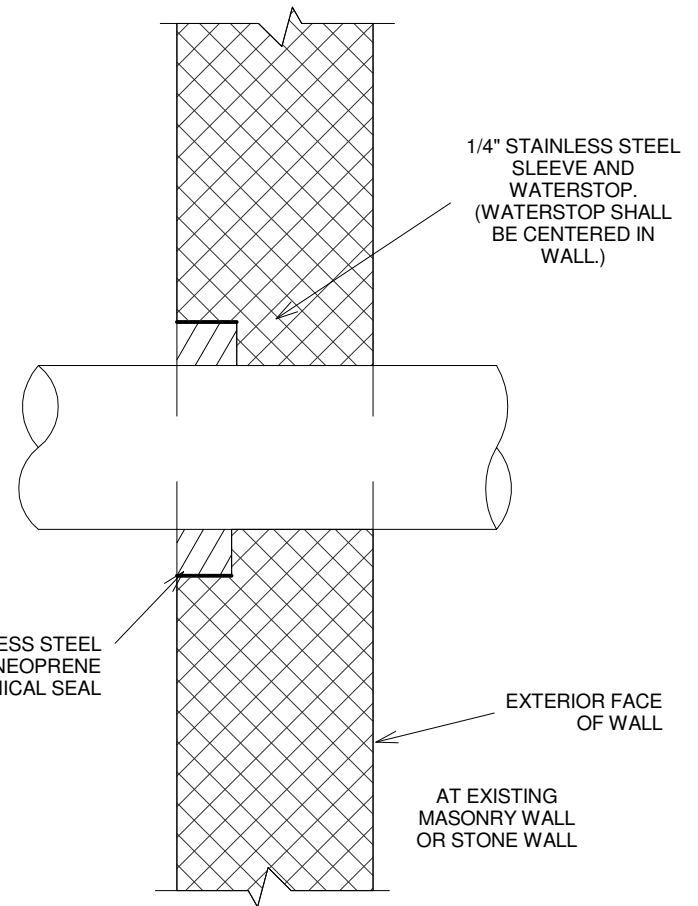

AT EXISTING  
MASONRY WALL  
OR STONE WALL

- NOTES:
1. FOR CMU WALL PROVIDE MIN. 3" NON-SHRINK GROUT AROUND WATERSTOP.
  2. COORDINATE SLEEVE SIZE AND O.D. OF PIPE WITH MECHANICAL SEAL MANUFACTURER.

**sde**  
Soil-Environmental  
ENGINEERING  
354 Merrimack Street, Suite 200  
Lawrence, MA 01843-1755

**ssv**  
ENGINEERING INC.

JULY 2013
N.T.S.

CITY OF WALTHAM SUMP PUMP AMNESTY PROGRAM  
CONTRACT 2- AREAS 5B, 5D, & 15

DETAIL 7-PIPE SLEEVE AT EXISTING WALLS

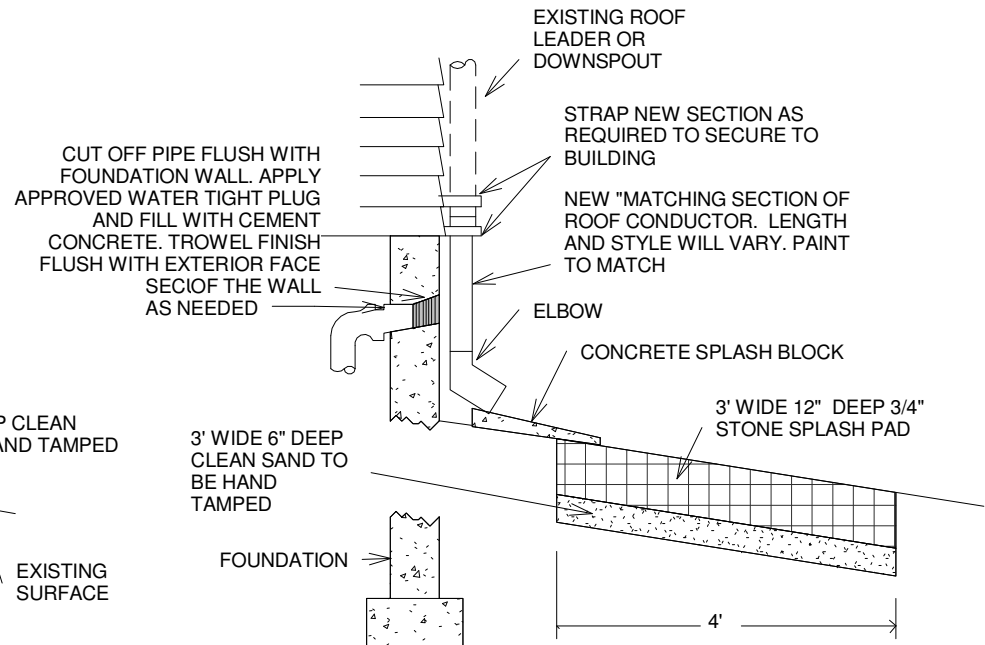
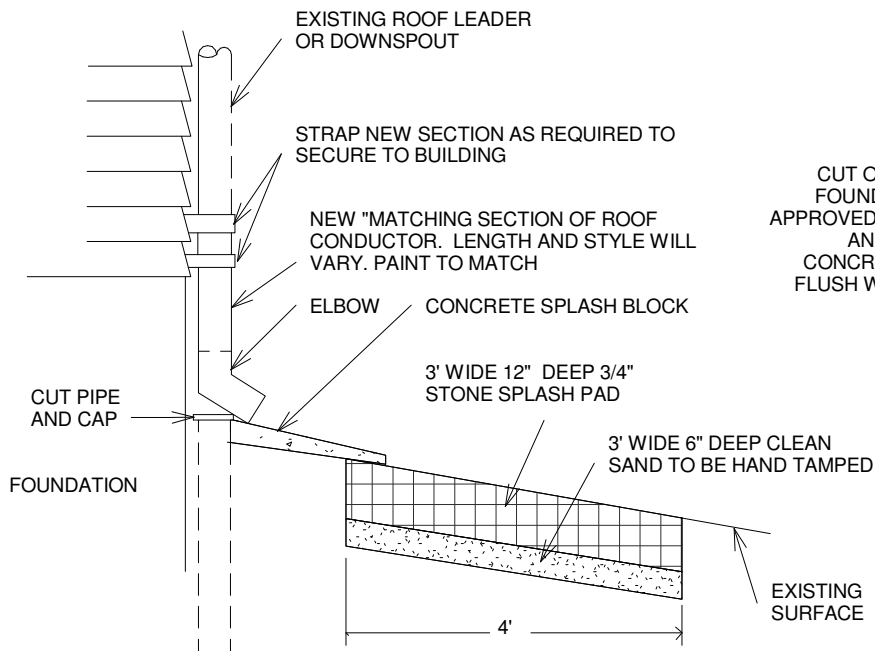

**sde**  
Soil-Environmental  
ENGINEERING

354 Merrimack Street, Suite 200  
Lawrence, MA 01843-1755



JULY 2013

N.T.S.

CITY OF WALTHAM SUMP PUMP AMNESTY PROGRAM  
CONTRACT 2- AREAS 5B, 5D, & 15

DETAIL 6-CUT AND SPLASH DOWNSPOUT DETAIL

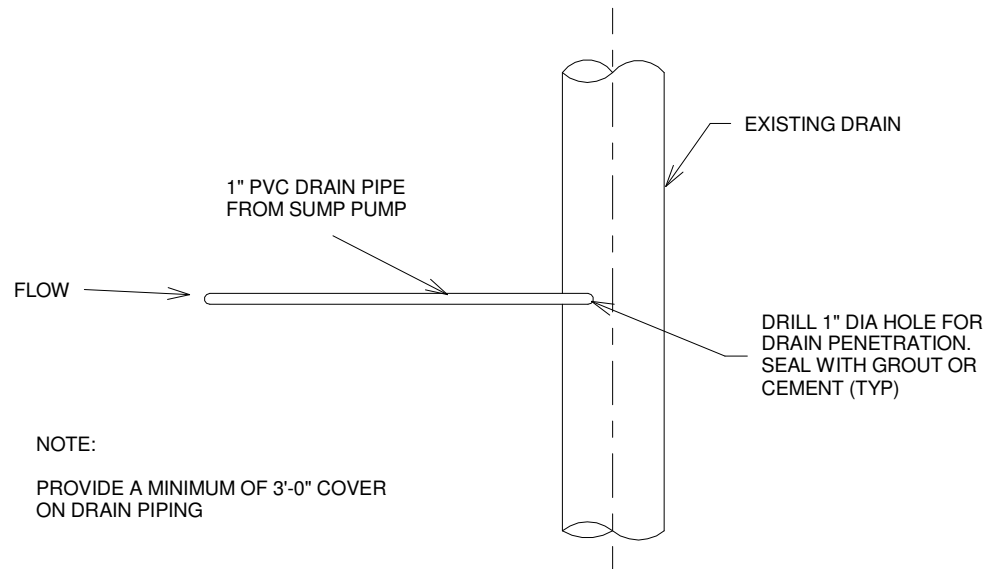

SUMP PUMP DISCHARGE CONNECTION TO EXISTING DRAIN PIPE

**sde**  
Soil-Environmental  
ENGINEERING

354 Merrimack Street, Suite 200  
Lawrence, MA 01843-1755

**ssv**  
ENGINEERING INC.

JULY 2013

N.T.S.

CITY OF WALTHAM SUMP PUMP AMNESTY PROGRAM  
CONTRACT 2- AREAS 5B, 5D, & 15

DETAIL 5B-CONNECTION TO EXISTING DRAIN

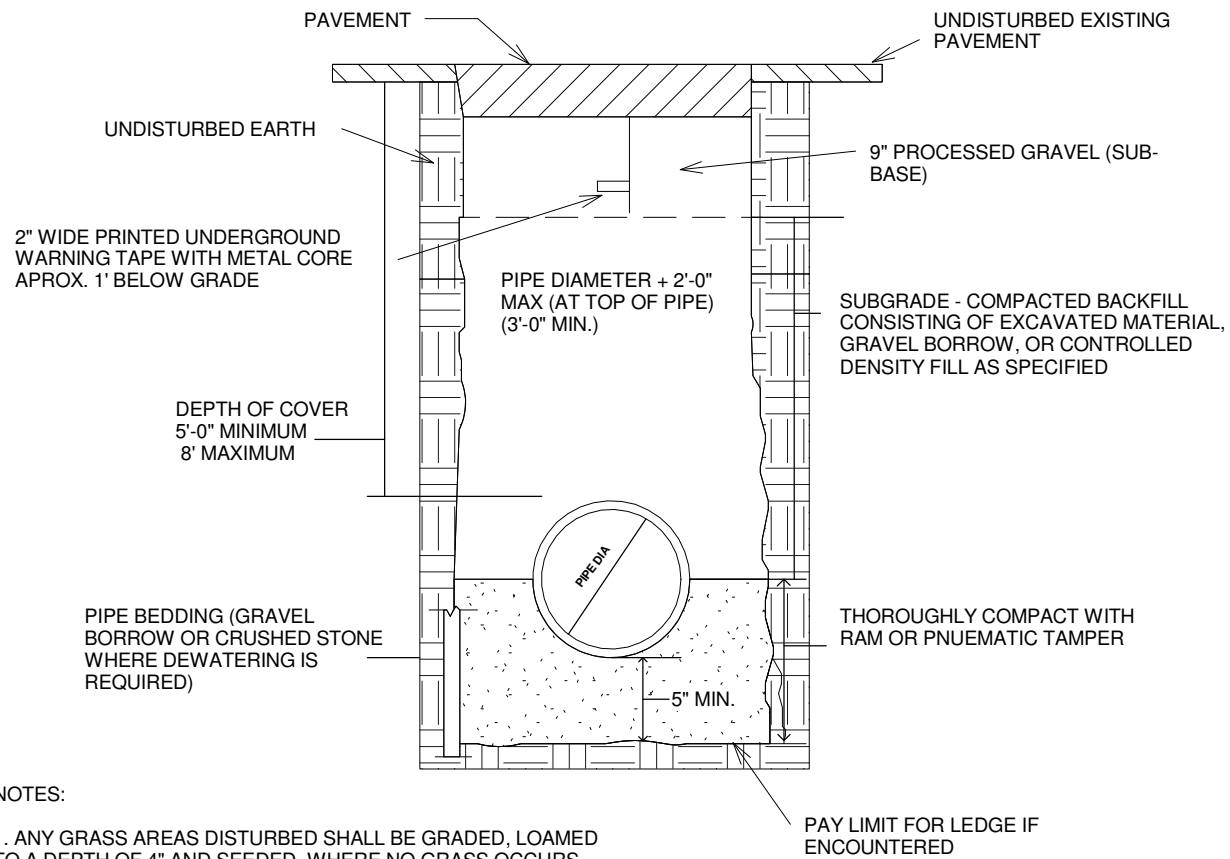

**sde**  
 civil + environmental  
 ENGINEERING  
 354 Merrimack Street, Suite 200  
 Lawrence, MA 01843-1755

**ssv**  
 ENGINEERING INC.

JULY 2013

N.T.S.

CITY OF WALTHAM SUMP PUMP AMNESTY PROGRAM  
 CONTRACT 2- AREAS 5B, 5D, & 15

DETAIL 4-PIPE TRENCH DETAIL

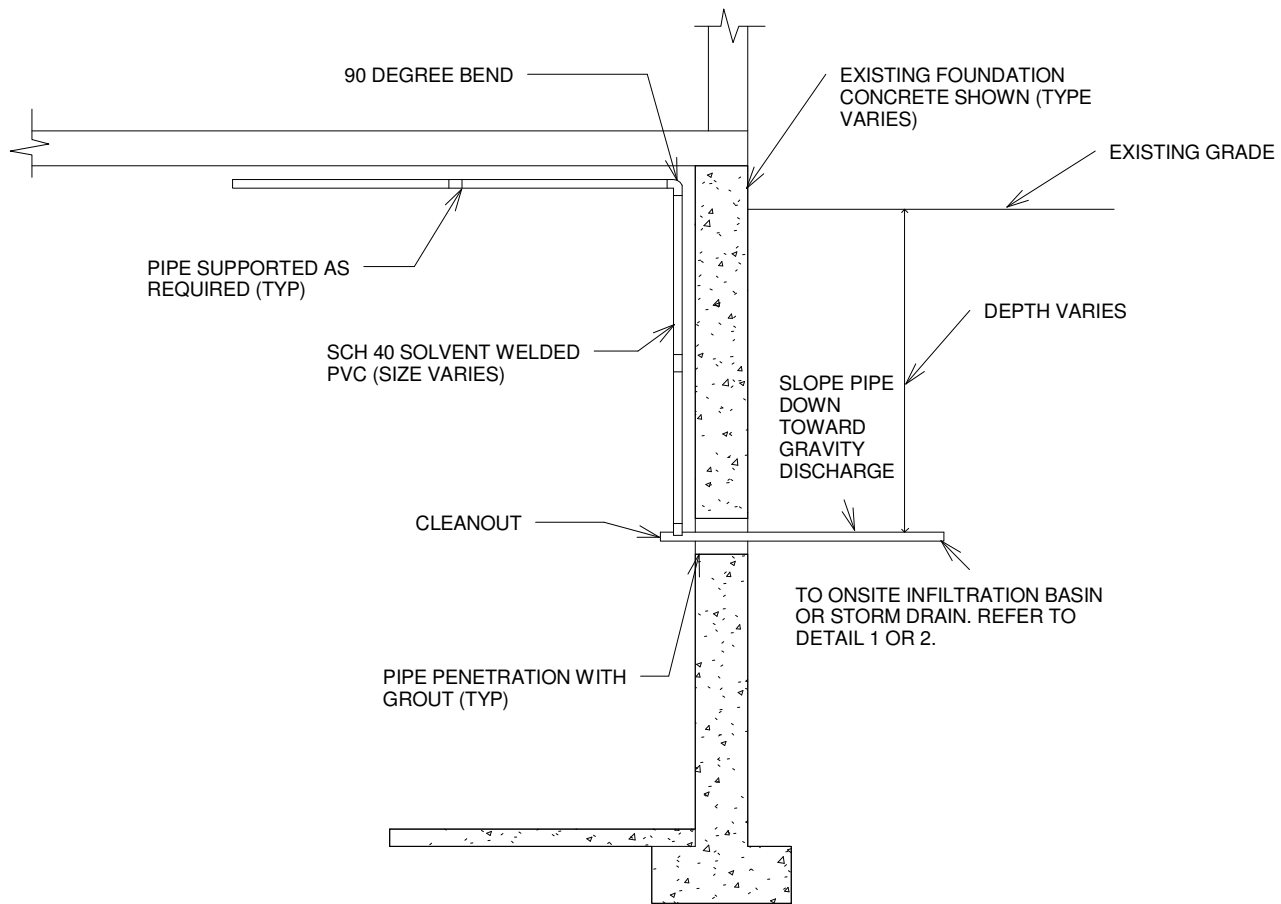

**sde**  
 Soil-Environmental  
 ENGINEERING  
 354 Merrimack Street, Suite 200  
 Lawrence, MA 01843-1755

**ssv**  
 ENGINEERING INC.

JULY 2013

N.T.S.

CITY OF WALTHAM SUMP PUMP AMNESTY PROGRAM  
 CONTRACT 2- AREAS 5B, 5D, & 15

DETAIL 3-INTERNAL PIPING DETAIL

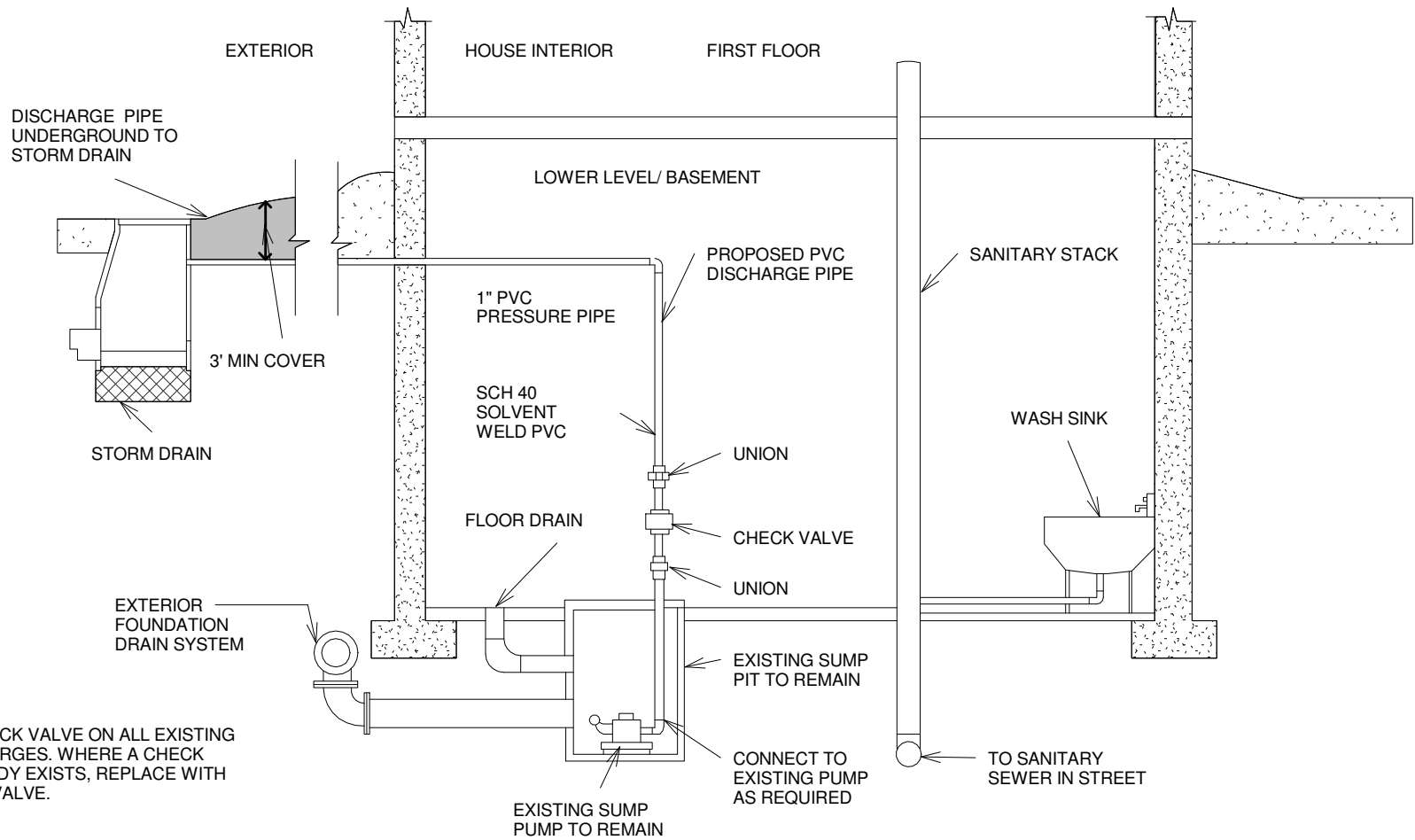

**NOTE:**

PROVIDE CHECK VALVE ON ALL EXISTING SUMP DISCHARGES. WHERE A CHECK VALVE ALREADY EXISTS, REPLACE WITH NEW CHECK VALVE.

**sde**  
 civil & environmental  
 ENGINEERING  
 354 Merrimack Street, Suite 200  
 Lawrence, MA 01843-1755



JULY 2013

N.T.S.

**CITY OF WALTHAM SUMP PUMP AMNESTY PROGRAM  
 CONTRACT 2- AREAS 5B, 5D, & 15**

DETAIL 2-DISCHARGE TO STORM DRAIN

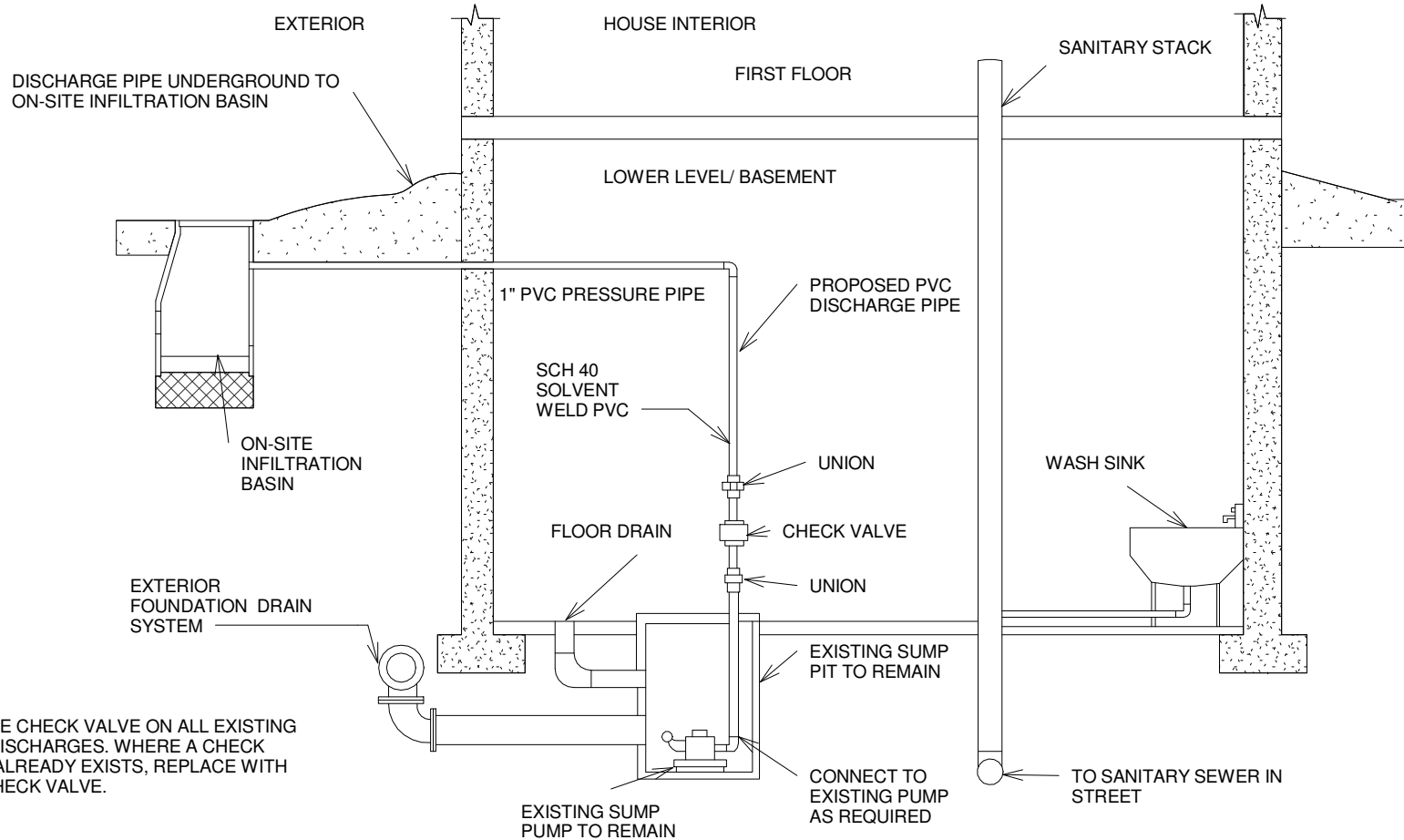

NOTE:  
 PROVIDE CHECK VALVE ON ALL EXISTING  
 SUMP DISCHARGES. WHERE A CHECK  
 VALVE ALREADY EXISTS, REPLACE WITH  
 NEW CHECK VALVE.

**sde**  
 soil + environmental  
 ENGINEERING  
 354 Merrimack Street, Suite 200  
 Lawrence, MA 01843-1755

**ssv**  
 ENGINEERING INC.

JULY 2013

---

N.T.S.

CITY OF WALTHAM SUMP PUMP AMNESTY PROGRAM  
 CONTRACT 2- AREAS 5B, 5D, & 15

DETAIL 1-DISCHARGE TO ONSITE INFILTRATION BASIN



FIGURE NAME:

141.000.B – TRENCH PAVEMENT DETAILS

SCALE:

NOT TO SCALE

CITY OF WALTHAM, MA. – ENGINEERING DEPARTMENT

REV. DATE:

4/13/2011

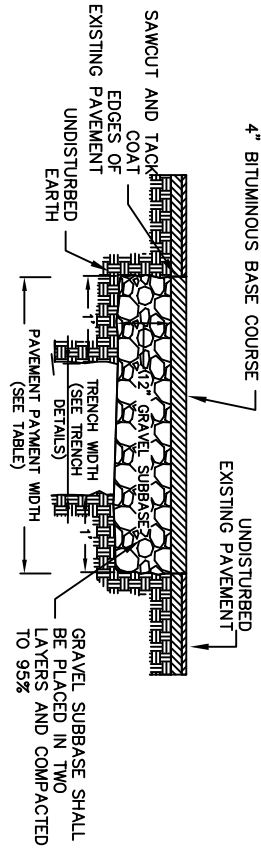

TRENCH PAY LIMIT TABLE FOR TEMPORARY PAVEMENT

PIPE SIZE (I.D.)	DEPTH TO PIPE INVERT				PAVEMENT WIDTH
	0 - 8'	OVER 8' - 12'	OVER 12' - 16'	OVER 16' - 20'	
0" - 24"	6'-6"	9'-6"	12'-6"	15'-6"	PAVEMENT WIDTH
OVER 24"	O.D. + 4'-0"	O.D. + 7'-0"	O.D. + 10'-0"	O.D. + 13'-0"	

I.D. = INSIDE DIMENSION  
O.D. = OUTSIDE DIMENSION

FOR EACH ADDITIONAL 4'-0" OF PIPE INVERT DEPTH OVER 20', ADD 3'-0" TO WIDTH LIMITS

TEMPORARY PAVEMENT DEPTH SHALL BE 3-IN.

TEMPORARY TRENCH PAVEMENT

DETAIL

- TEMPORARY AND PERMANENT TRENCH PAVEMENT NOTES:**
1. PERMANENT TRENCH PAVEMENT PAYMENT WIDTH SHALL BE THE TRENCH PAY LIMIT PLUS 2 FEET
  2. TEMPORARY TRENCH PAVEMENT PAYMENT WIDTH SHALL BE EQUAL TO THE TRENCH PAYMENT LIMIT
  3. REMOVE AND DISPOSE ALL TEMPORARY PAVEMENT AS REQUIRED. RESTORE AND COMPACT SUBBASE AS REQUIRED PRIOR TO PERMANENT TRENCH PAVEMENT.
  4. DEPTH OF PERMANENT TRENCH PAVEMENT SHALL BE THE SAME THICKNESS AS THE EXISTING PAVEMENT.

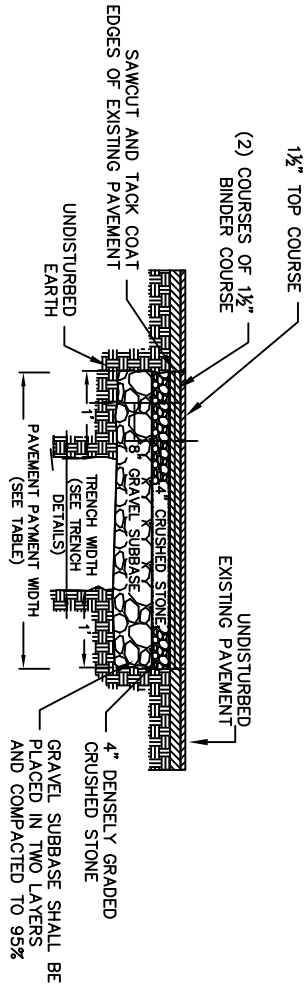

TRENCH PAY LIMIT TABLE FOR PERMANENT PAVEMENT

PIPE SIZE (I.D.)	DEPTH TO PIPE INVERT				PAVEMENT WIDTH
	0 - 8'	OVER 8' - 12'	OVER 12' - 16'	OVER 16' - 20'	
0" - 24"	8'-6"	11'-6"	14'-6"	17'-6"	PAVEMENT WIDTH
OVER 24"	O.D. + 6'-0"	O.D. + 9'-0"	O.D. + 12'-0"	O.D. + 15'-0"	

I.D. = INSIDE DIMENSION  
O.D. = OUTSIDE DIMENSION

FOR EACH ADDITIONAL 4'-0" OF PIPE INVERT DEPTH OVER 20', ADD 3'-0" TO WIDTH LIMITS

PERMANENT TRENCH PAVEMENT

DETAIL



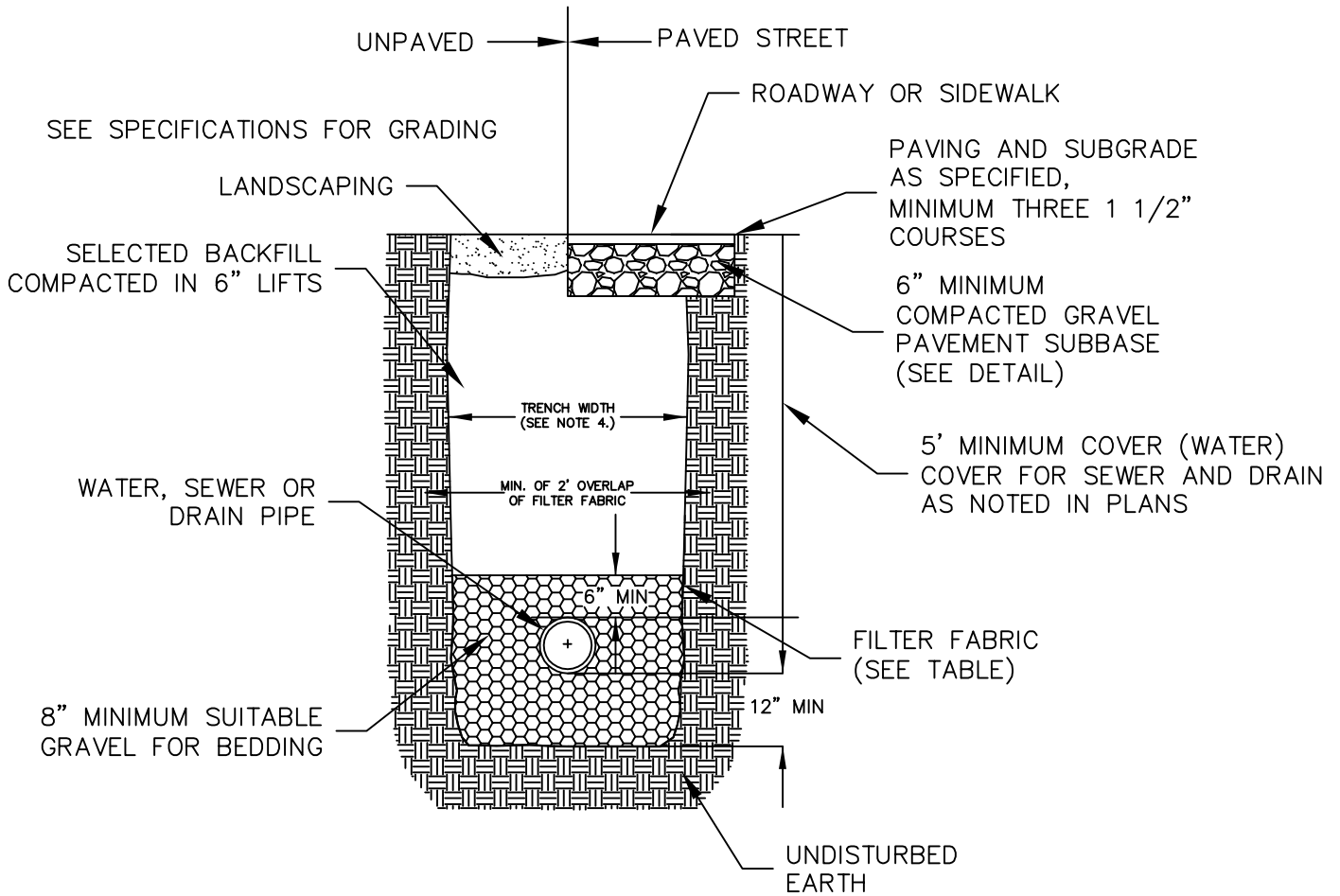

NOTES:

1. ALL TRENCHES MUST BE JETTED OR PUDDLED AS REQUIRED BY THE ENGINEER.
2. PRIOR TO FINISHING PAVING, CUT SQUARE EDGES AT EXISTING PAVEMENT, AT LEAST 6 INCHES BEYOND OUTERMOST DISTURBED PAVEMENT.
3. NO LEDGE TO BE WITHIN 6" OF PIPE.
4. TRENCH WIDTH:

LEDGE: OUTSIDE DIAMETER OF PIPE PLUS 2 FEET

EARTH: GREATER OF LEDGE VALUE OR 3 FEET (OR AS DETERMINED BY THE ENGINEER)

FILTER FABRIC USE

	SOIL TYPE	
	SILT OR CLAY	GRANULAR SOIL
ABOVE GROUND WATER	FILTER FABRIC NOT REQUIRED	FILTER FABRIC NOT REQUIRED
BELOW GROUND WATER	FILTER FABRIC REQUIRED	FILTER FABRIC NOT REQUIRED

# WATER, SEWER, AND DRAIN TRENCH DETAIL

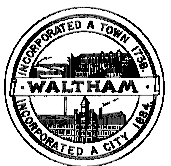

FIGURE NAME:

141.000.A – TRENCH DETAIL

SCALE:

NOT TO SCALE

CITY OF WALTHAM, MA. – ENGINEERING DEPARTMENT  
STANDARD DETAILS

REV. DATE:

3/30/2011

345

TABLE 1				
MANHOLE DIAMETER	SIDE WALL MIN. THICKNESS	BOTTOM SLAB MIN. THICKNESS	MAX PIPE RCP	DIAMETER * DI/PVC
4'	5"	6"	24"	30"
5'	6"	8"	36"	42"
6'	7"	8"	48"	54"
8'	9"	8"	66"	72"
10'	11"	10"	72"	84"

\* MAY VARY DEPENDING ON SIZE AND LOCATION OF ADDITIONAL PENETRATIONS OR RELATIONSHIP OF PENETRATIONS IN MANHOLE

WALL THICKNESS	MAX TRENCH WIDTH
LESS THAN 6"	I.D. + 5'-0"
6" TO 12"	I.D. + 6'-0"
13" TO 18"	I.D. + 7'-0"
19" & GREATER	O.D. + 6'-0"

I.D. = INSIDE DIMENSION  
O.D. = OUTSIDE DIMENSION

FOR TRENCHES GREATER THAN 5' DEEP ADD 3' FOR TEMPORARY SUPPORT OF EXCAVATION

MANHOLE GENERAL NOTES:

- HIGHEST POINT OF BRICK TABLE AT MANHOLE WALL, TO BE AT ELEV OF CROWN OF PIPE. TABLE TO SLOPE AT 8.3%.
- SEWER OR DRAIN MANHOLE DIAMETER SHALL BE 4', 5', 6', 8' OR 10' AS SHOWN ON PLAN/PROFILE VIEWS.
- DESIGN PRECAST SECTIONS WITH FRAME AND COVER FOR AASHTO H20 LOADINGS. UNLESS OTHERWISE NOTED
- PRECAST MANHOLES SHALL BE PRE-ORDERED WITH PENETRATIONS AT ELEVATIONS INDICATED ON CONTRACT DRAWINGS.

GENERAL MANHOLE DETAILS

	FIGURE NAME: 202.000.D – GENERAL MANHOLE NOTES	SCALE: NOT TO SCALE
	CITY OF WALTHAM, MA. – ENGINEERING DEPARTMENT STANDARD DETAILS	REV. DATE: 12/8/2010 346

TABLE 1				
MANHOLE DIAMETER	SIDE WALL MIN. THICKNESS	BOTTOM SLAB MIN. THICKNESS	MAX PIPE RCP	DIAMETER * DI/PVC
4'	5"	6"	24"	30"
5'	6"	8"	36"	42"
6'	7"	8"	48"	54"
8'	9"	8"	66"	72"
10'	11"	10"	72"	84"

\* MAY VARY DEPENDING ON SIZE AND LOCATION OF ADDITIONAL PENETRATIONS OR RELATIONSHIP OF PENETRATIONS IN MANHOLE

WALL THICKNESS	MAX TRENCH WIDTH
LESS THAN 6"	I.D. + 5'-0"
6" TO 12"	I.D. + 6'-0"
13" TO 18"	I.D. + 7'-0"
19" & GREATER	O.D. + 6'-0"

I.D. = INSIDE DIMENSION  
O.D. = OUTSIDE DIMENSION

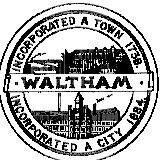
FOR TRENCHES GREATER THAN 5' DEEP ADD 3' FOR TEMPORARY SUPPORT OF EXCAVATION

MANHOLE GENERAL NOTES:

- HIGHEST POINT OF BRICK TABLE AT MANHOLE WALL, TO BE AT ELEV OF CROWN OF PIPE. TABLE TO SLOPE AT 8.3%.
- SEWER OR DRAIN MANHOLE DIAMETER SHALL BE 4', 5', 6', 8' OR 10' AS SHOWN ON PLAN/PROFILE VIEWS.
- DESIGN PRECAST SECTIONS WITH FRAME AND COVER FOR AASHTO H20 LOADINGS. UNLESS OTHERWISE NOTED
- PRECAST MANHOLES SHALL BE PRE-ORDERED WITH PENETRATIONS AT ELEVATIONS INDICATED ON CONTRACT DRAWINGS.

GENERAL MANHOLE DETAILS

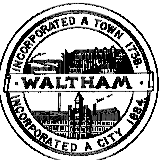
	FIGURE NAME: 202.000.D – GENERAL MANHOLE NOTES	SCALE: NOT TO SCALE
	CITY OF WALTHAM, MA. – ENGINEERING DEPARTMENT STANDARD DETAILS	REV. DATE: 12/8/2010 347

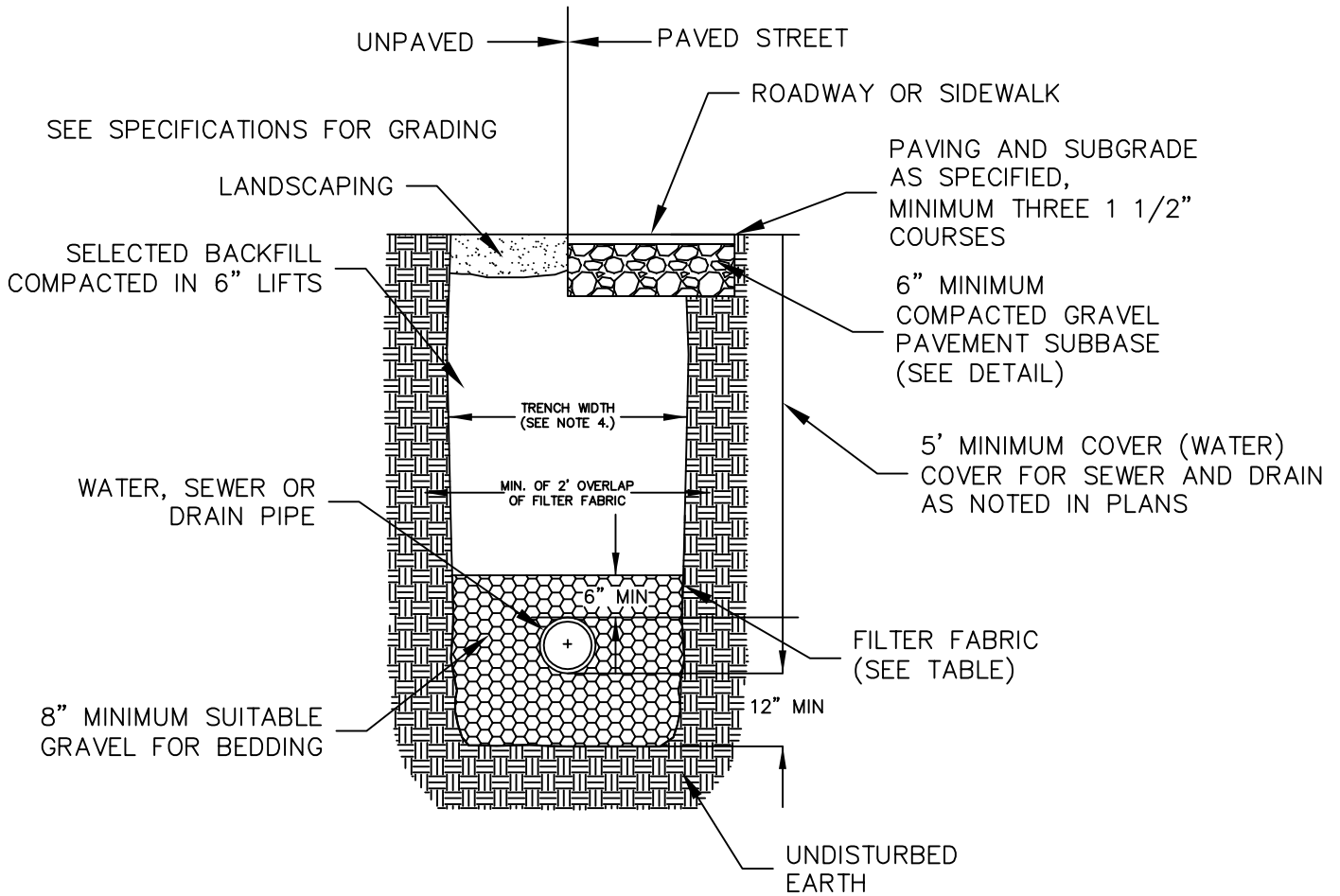

NOTES:

1. ALL TRENCHES MUST BE JETTED OR PUDDLED AS REQUIRED BY THE ENGINEER.
2. PRIOR TO FINISHING PAVING, CUT SQUARE EDGES AT EXISTING PAVEMENT, AT LEAST 6 INCHES BEYOND OUTERMOST DISTURBED PAVEMENT.
3. NO LEDGE TO BE WITHIN 6" OF PIPE.
4. TRENCH WIDTH:

LEDGE: OUTSIDE DIAMETER OF PIPE PLUS 2 FEET

EARTH: GREATER OF LEDGE VALUE OR 3 FEET (OR AS DETERMINED BY THE ENGINEER)

FILTER FABRIC USE

	SOIL TYPE	
	SILT OR CLAY	GRANULAR SOIL
ABOVE GROUND WATER	FILTER FABRIC NOT REQUIRED	FILTER FABRIC NOT REQUIRED
BELOW GROUND WATER	FILTER FABRIC REQUIRED	FILTER FABRIC NOT REQUIRED

# WATER, SEWER, AND DRAIN TRENCH DETAIL

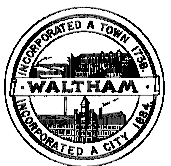

FIGURE NAME:

141.000.A – TRENCH DETAIL

SCALE:

NOT TO SCALE

CITY OF WALTHAM, MA. – ENGINEERING DEPARTMENT  
STANDARD DETAILS

REV. DATE:

3/30/2011

348

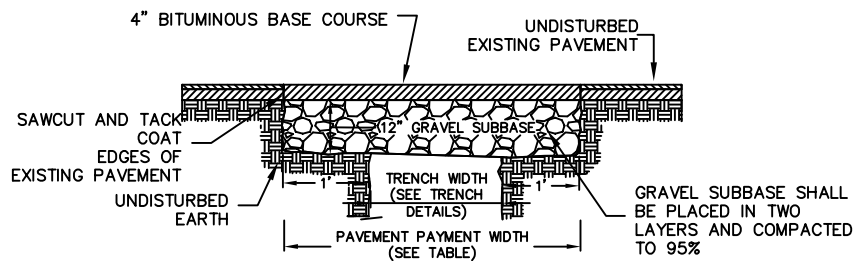

TRENCH PAY LIMIT TABLE FOR TEMPORARY PAVEMENT

PIPE SIZE (I.D.)	DEPTH TO PIPE INVERT				PAY WIDTH
	0 - 8'	OVER 8' - 12'	OVER 12' - 16'	OVER 16' - 20'	
0" - 24"	6'-6"	9'-6"	12'-6"	15'-6"	
OVER 24"	O.D. + 4'-0"	O.D. + 7'-0"	O.D. + 10'-0"	O.D. + 13'-0"	

I.D. = INSIDE DIMENSION  
O.D. = OUTSIDE DIMENSION

FOR EACH ADDITIONAL 4'-0" OF PIPE INVERT DEPTH OVER 20', ADD 3'-0" TO WIDTH LIMITS

TEMPORARY PAVEMENT DEPTH SHALL BE 3-IN.

TEMPORARY TRENCH PAVEMENT  
DETAIL

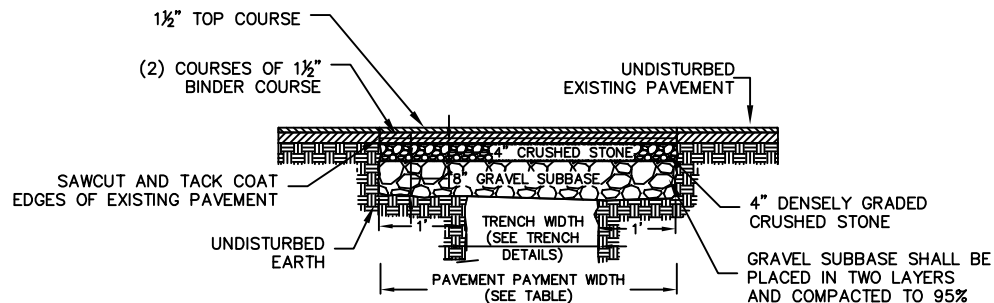

TRENCH PAY LIMIT TABLE FOR PERMANENT PAVEMENT

PIPE SIZE (I.D.)	DEPTH TO PIPE INVERT				PAY WIDTH
	0 - 8'	OVER 8' - 12'	OVER 12' - 16'	OVER 16' - 20'	
0" - 24"	8'-6"	11'-6"	14'-6"	17'-6"	
OVER 24"	O.D. + 6'-0"	O.D. + 9'-0"	O.D. + 12'-0"	O.D. + 15'-0"	

I.D. = INSIDE DIMENSION  
O.D. = OUTSIDE DIMENSION

FOR EACH ADDITIONAL 4'-0" OF PIPE INVERT DEPTH OVER 20', ADD 3'-0" TO WIDTH LIMITS

PERMANENT TRENCH PAVEMENT  
DETAIL

TEMPORARY AND PERMANENT TRENCH PAVEMENT NOTES:

1. PERMANENT TRENCH PAVEMENT PAYMENT WIDTH SHALL BE THE TRENCH PAY LIMIT PLUS 2 FEET
2. TEMPORARY TRENCH PAVEMENT PAYMENT WIDTH SHALL BE EQUAL TO THE TRENCH PAYMENT LIMIT
3. REMOVE AND DISPOSE ALL TEMPORARY PAVEMENT AS REQUIRED. RESTORE AND COMPACT SUBBASE AS REQUIRED PRIOR TO PERMANENT TRENCH PAVEMENT.
4. DEPTH OF PERMANENT TRENCH PAVEMENT SHALL BE THE SAME THICKNESS AS THE EXISTING PAVEMENT.



FIGURE NAME:

141.000.B - TRENCH PAVEMENT DETAILS

SCALE:

NOT TO SCALE

CITY OF WALTHAM, MA. - ENGINEERING DEPARTMENT  
STANDARD DETAILS

REV. DATE:

4/13/2011 349

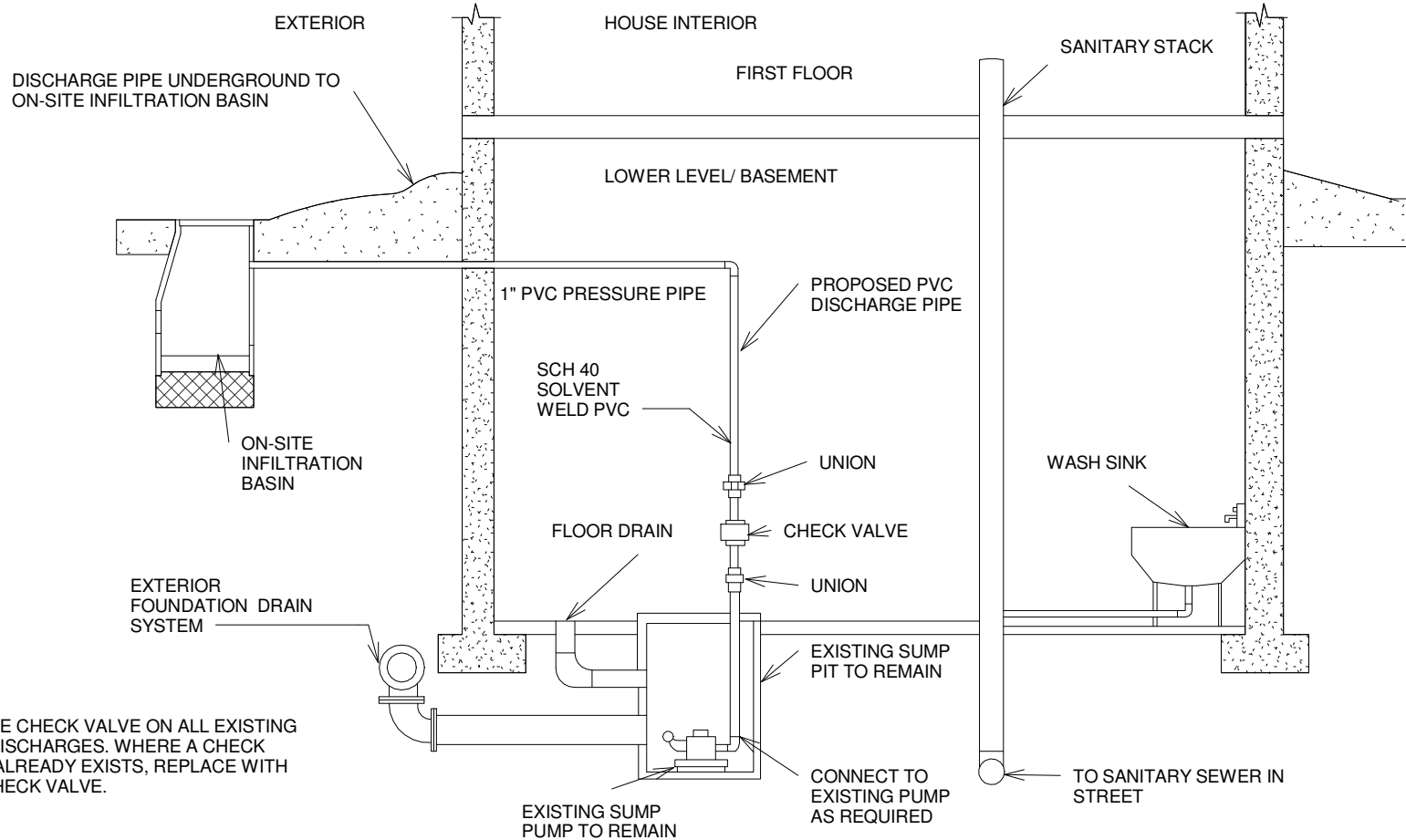

**NOTE:**

PROVIDE CHECK VALVE ON ALL EXISTING SUMP DISCHARGES. WHERE A CHECK VALVE ALREADY EXISTS, REPLACE WITH NEW CHECK VALVE.

**sde**  
 South Environmental  
 ENGINEERING  
 354 Merrimack Street, Suite 200  
 Lawrence, MA 01843-1755



JULY 2013

N.T.S.

**CITY OF WALTHAM SUMP PUMP AMNESTY PROGRAM  
 CONTRACT 2- AREAS 5B, 5D, & 15**

**DETAIL 1-DISCHARGE TO ONSITE INFILTRATION BASIN**

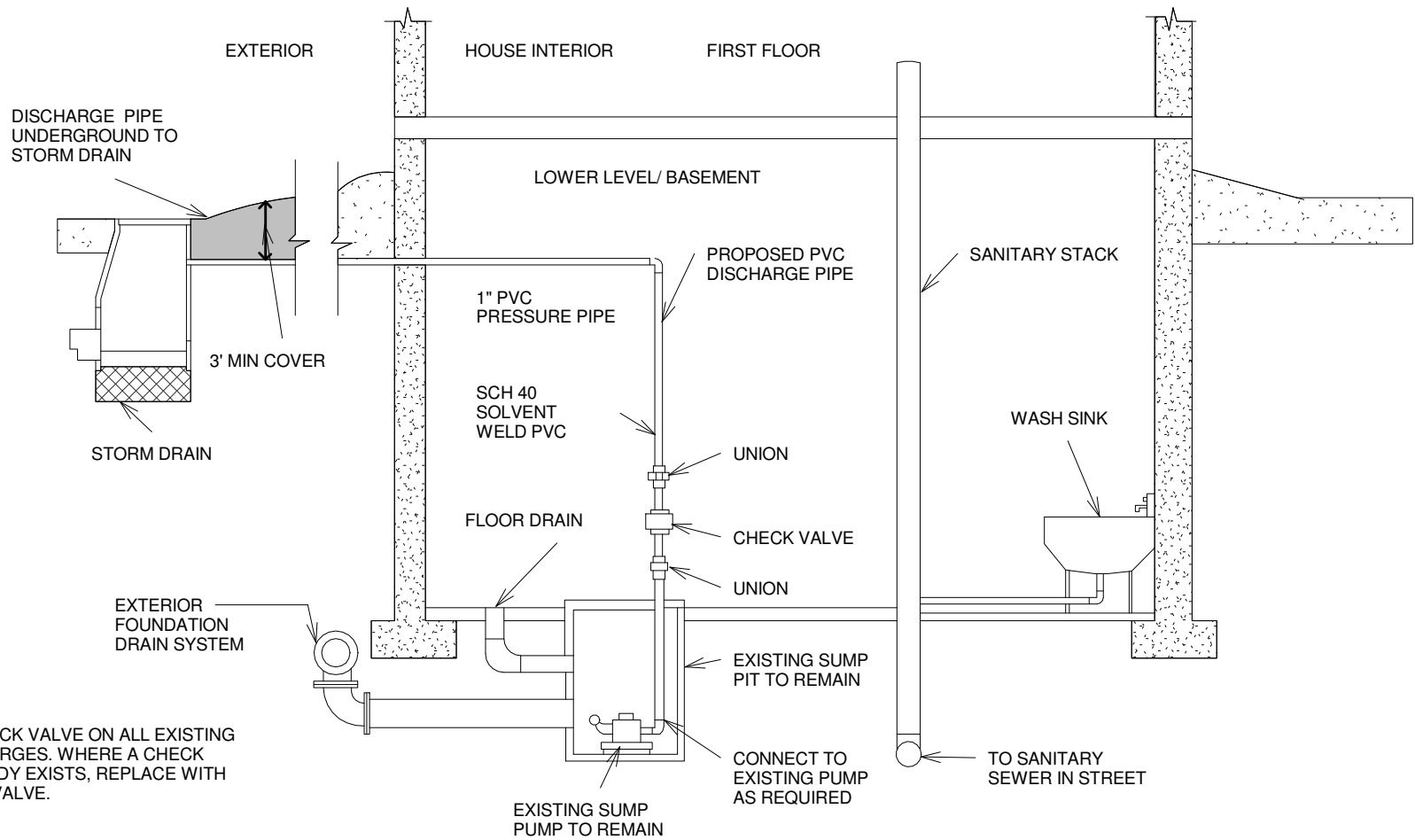

**NOTE:**

PROVIDE CHECK VALVE ON ALL EXISTING SUMP DISCHARGES. WHERE A CHECK VALVE ALREADY EXISTS, REPLACE WITH NEW CHECK VALVE.

**sde**  
 soil & environmental  
 ENGINEERING  
 354 Merrimack Street, Suite 200  
 Lawrence, MA 01843-1755



JULY 2013

N.T.S.

**CITY OF WALTHAM SUMP PUMP AMNESTY PROGRAM  
 CONTRACT 2- AREAS 5B, 5D, & 15**

DETAIL 2-DISCHARGE TO STORM DRAIN

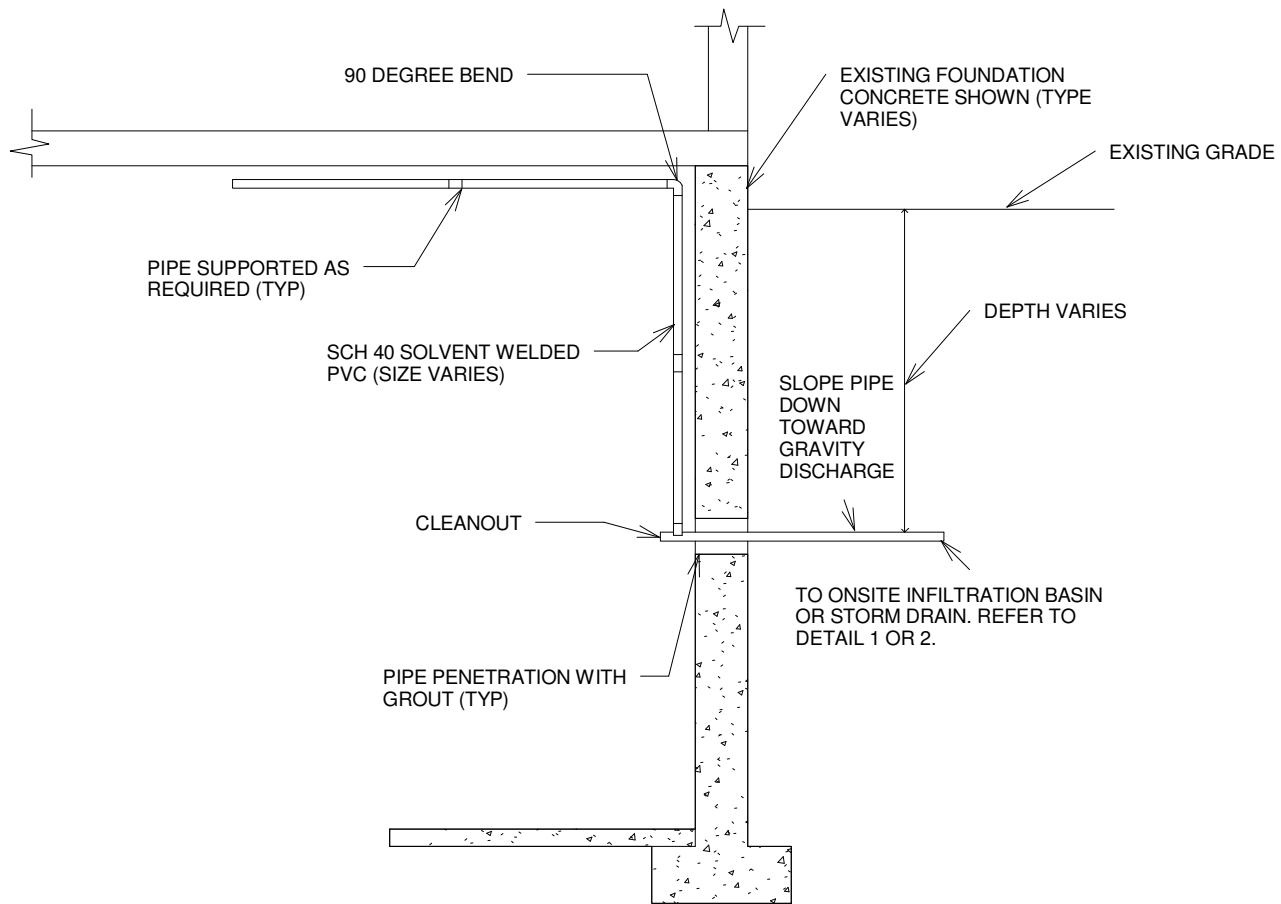

**sde**  
 Soil-Environmental  
 ENGINEERING  
 354 Merrimack Street, Suite 200  
 Lawrence, MA 01843-1755

**ssv**  
 ENGINEERING INC.

JULY 2013

N.T.S.

CITY OF WALTHAM SUMP PUMP AMNESTY PROGRAM  
 CONTRACT 2- AREAS 5B, 5D, & 15

DETAIL 3-INTERNAL PIPING DETAIL



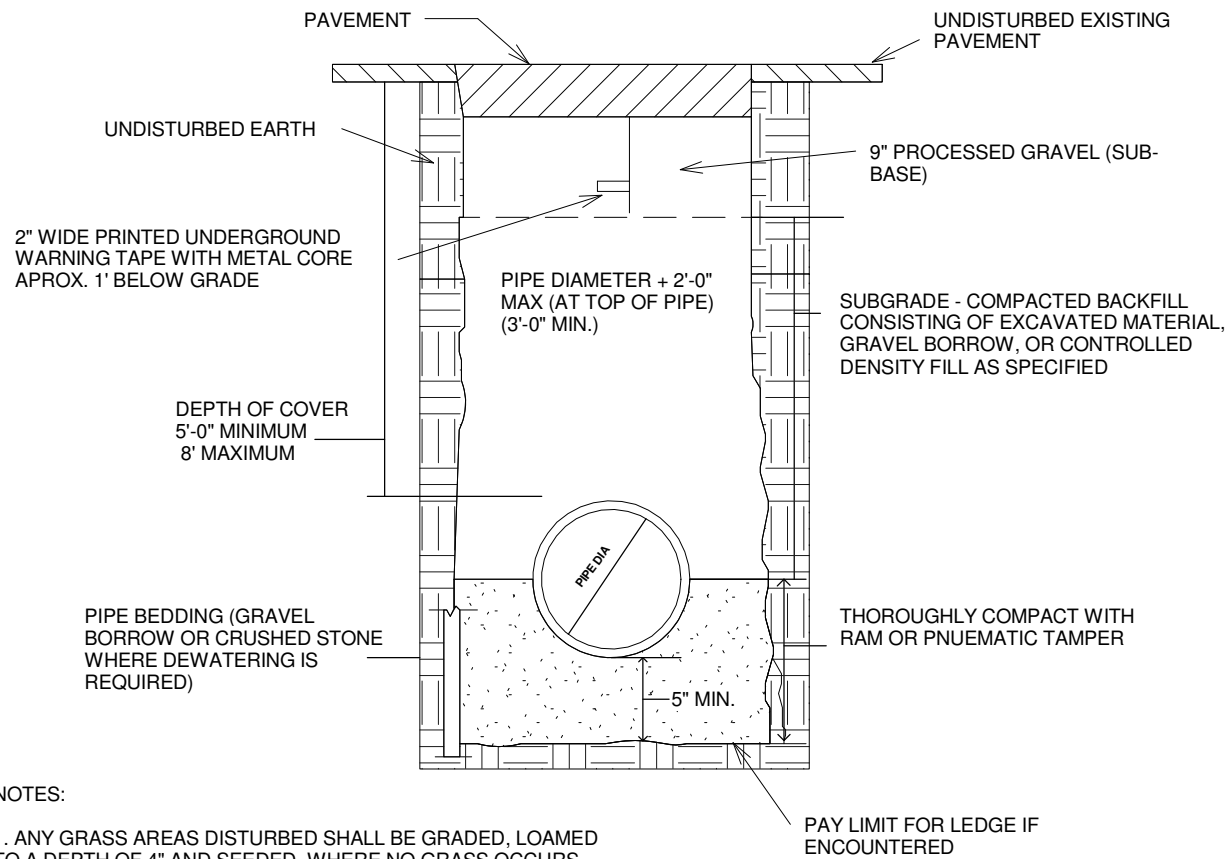

**sde**  
 civil + environmental  
 ENGINEERING  
 354 Merrimack Street, Suite 200  
 Lawrence, MA 01843-1755

**ssv**  
 ENGINEERING INC.

JULY 2013

N.T.S.

CITY OF WALTHAM SUMP PUMP AMNESTY PROGRAM  
 CONTRACT 2- AREAS 5B, 5D, & 15

DETAIL 4-PIPE TRENCH DETAIL

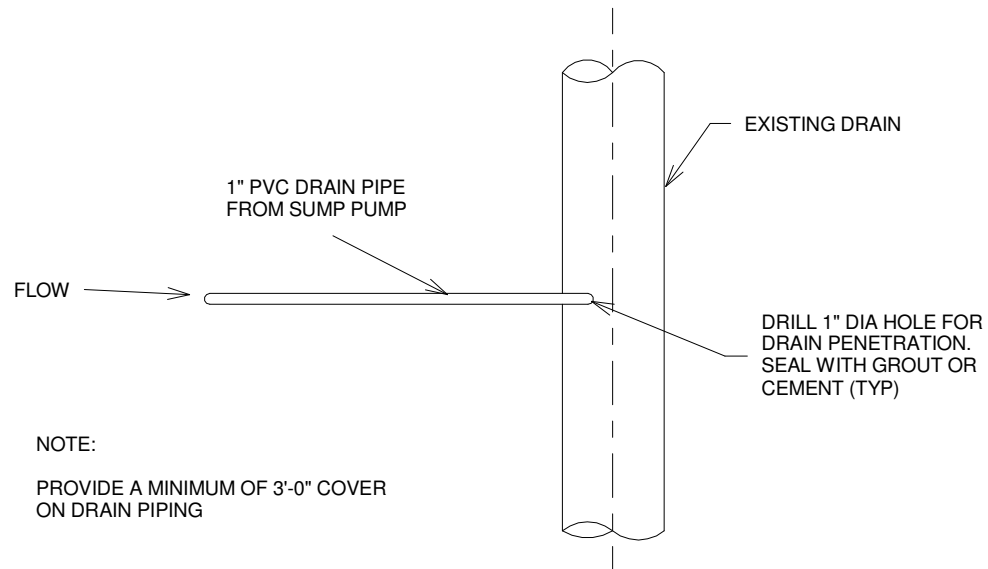

SUMP PUMP DISCHARGE CONNECTION TO EXISTING DRAIN PIPE

**sde**  
Soil & Environmental  
ENGINEERING

354 Merrimack Street, Suite 200  
Lawrence, MA 01843-1755

**ssv**  
ENGINEERING INC.

JULY 2013

N.T.S.

CITY OF WALTHAM SUMP PUMP AMNESTY PROGRAM  
CONTRACT 2- AREAS 5B, 5D, & 15

DETAIL 5B-CONNECTION TO EXISTING DRAIN

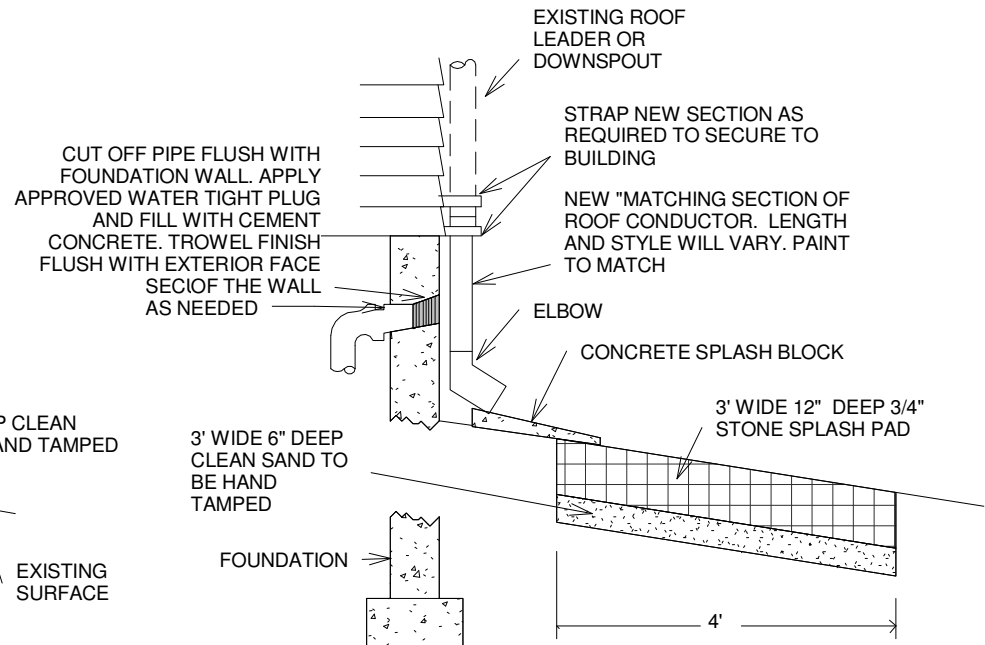
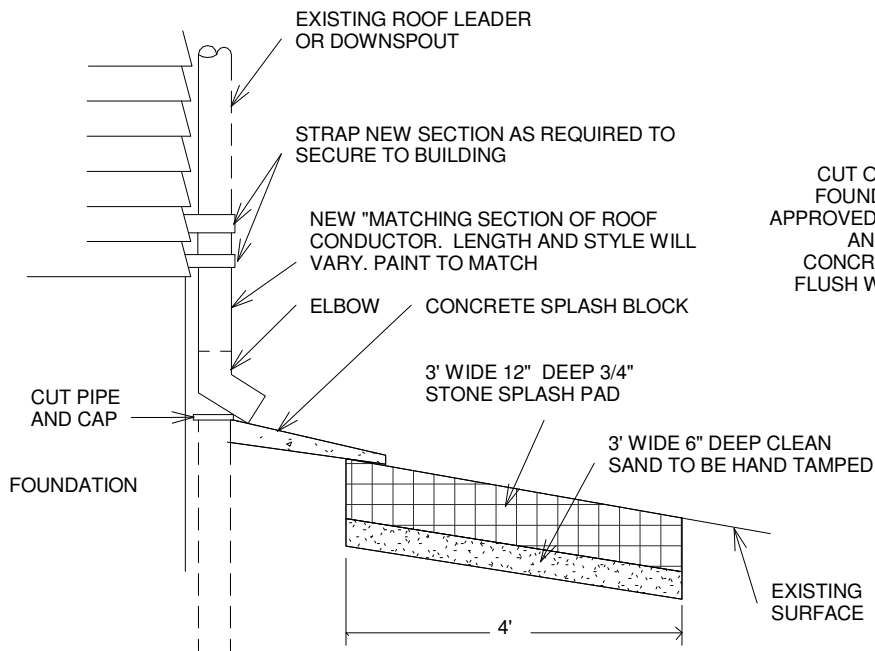

**sde**  
Soil-Environmental  
ENGINEERING

354 Merrimack Street, Suite 200  
Lawrence, MA 01843-1755



JULY 2013

N.T.S.

CITY OF WALTHAM SUMP PUMP AMNESTY PROGRAM  
CONTRACT 2- AREAS 5B, 5D, & 15

DETAIL 6-CUT AND SPLASH DOWNSPOUT DETAIL

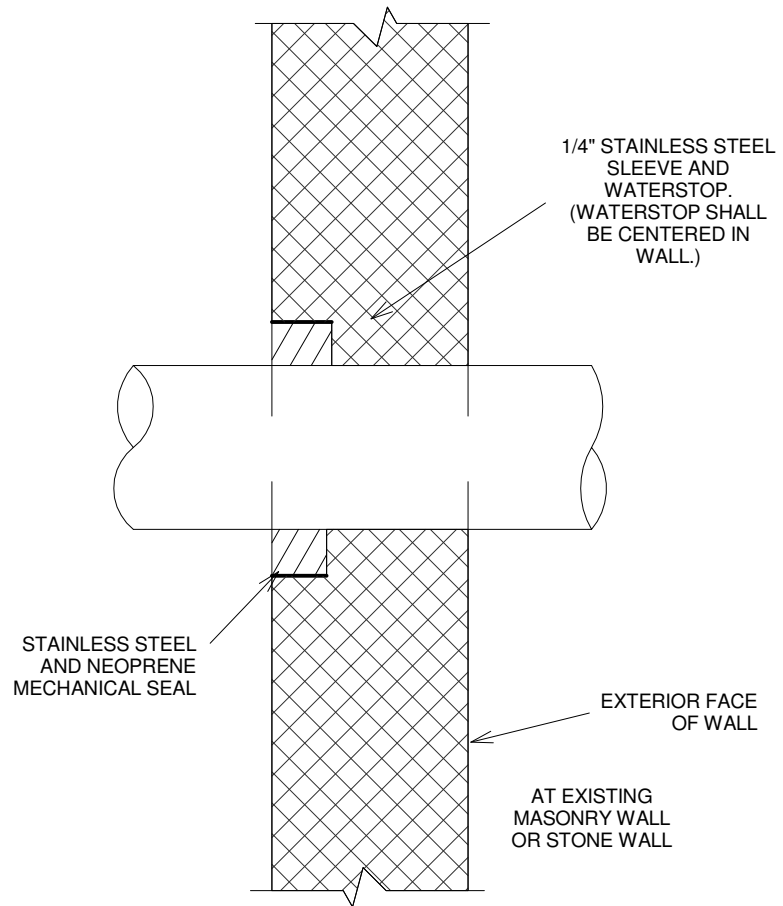
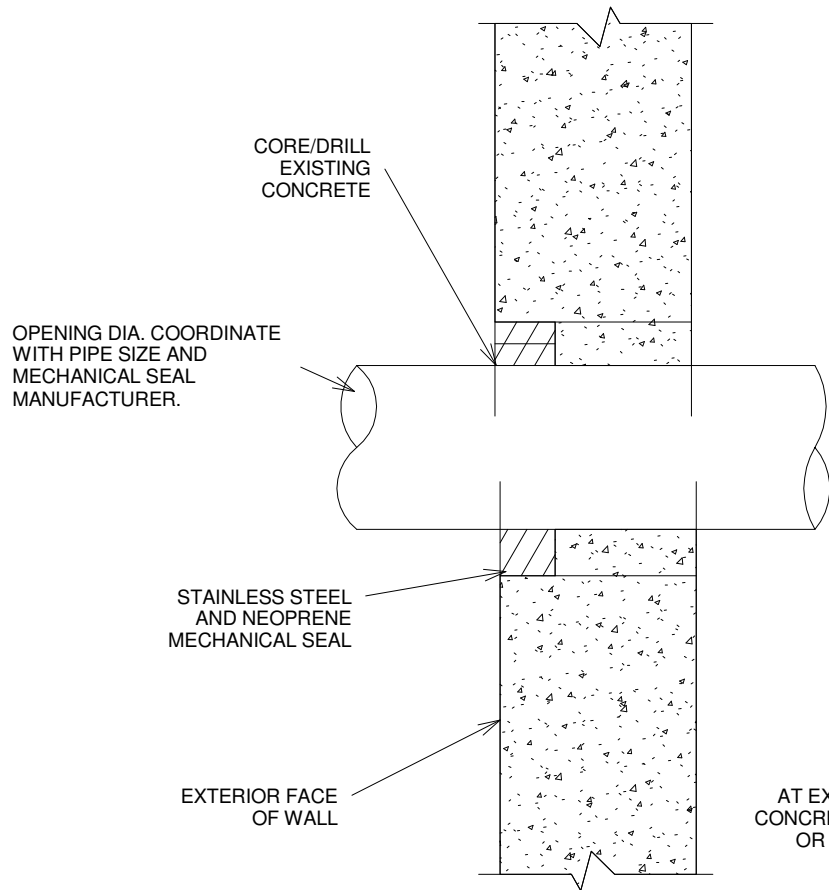

- NOTES:
1. FOR CMU WALL PROVIDE MIN. 3" NON-SHRINK GROUT AROUND WATERSTOP.
  2. COORDINATE SLEEVE SIZE AND O.D. OF PIPE WITH MECHANICAL SEAL MANUFACTURER.

**sde**  
Soil-Environmental  
ENGINEERING

354 Merrimack Street, Suite 200  
Lawrence, MA 01843-1755

**ssv**  
ENGINEERING INC.

JULY 2013
N.T.S.

CITY OF WALTHAM SUMP PUMP AMNESTY PROGRAM  
CONTRACT 2- AREAS 5B, 5D, & 15

DETAIL 7-PIPE SLEEVE AT EXISTING WALLS

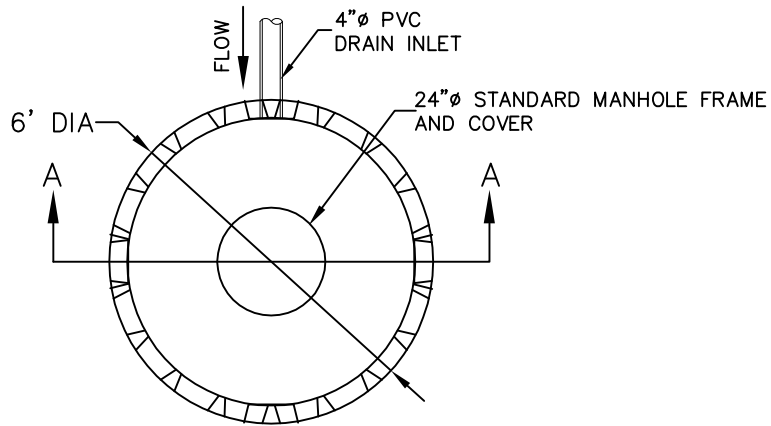

PLAN VIEW

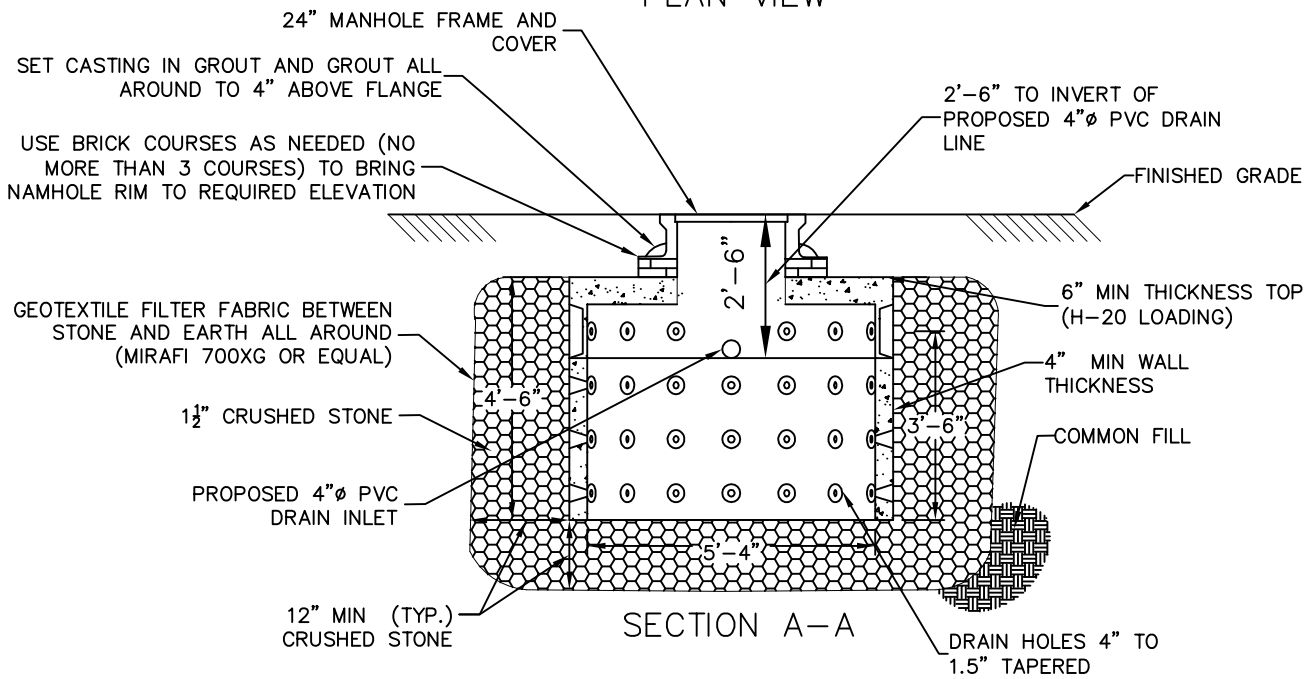

SECTION A-A

6' Ø CYLINDRICAL INFILTRATION BASIN

NOT TO SCALE

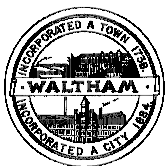

FIGURE NAME:

201.999 - 6' DIAMETER INFILTRATION BASIN

CITY OF WALTHAM, MA. - ENGINEERING DEPARTMENT  
STANDARD DETAILS

SCALE:

NOT TO SCALE

REV. DATE:

10/7/2010

357

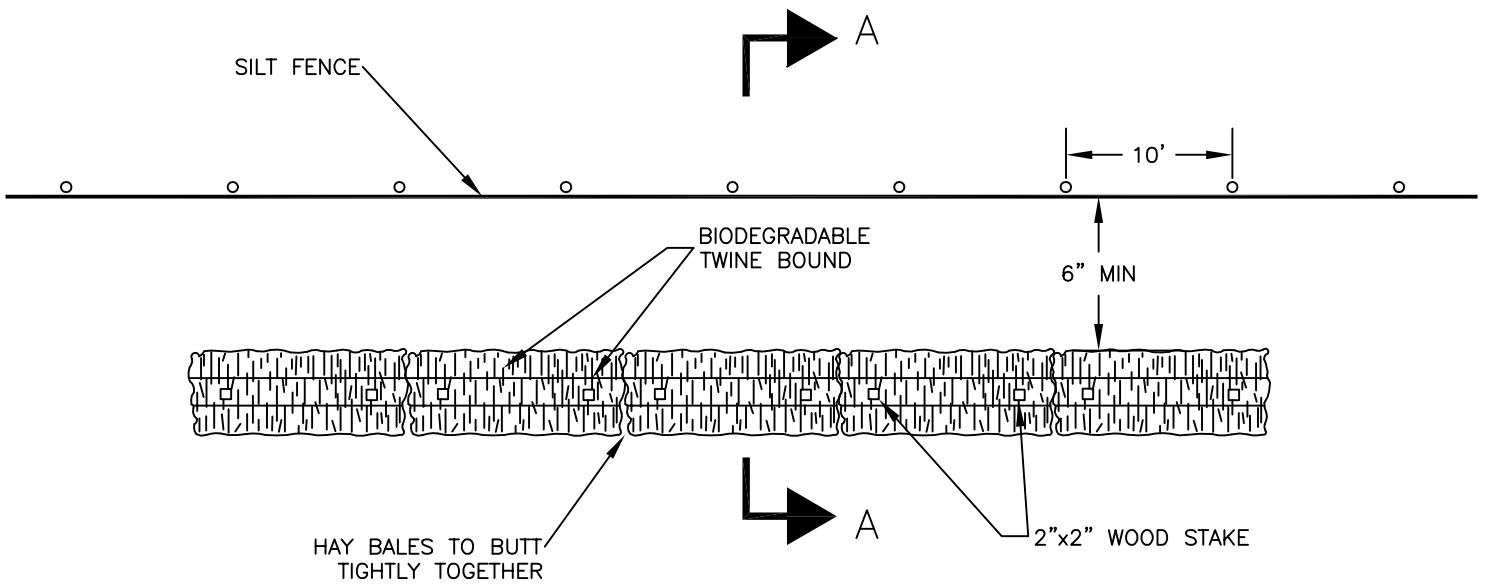

EROSION BARRIER  
HAY BALES AND SILT FENCE PLAN

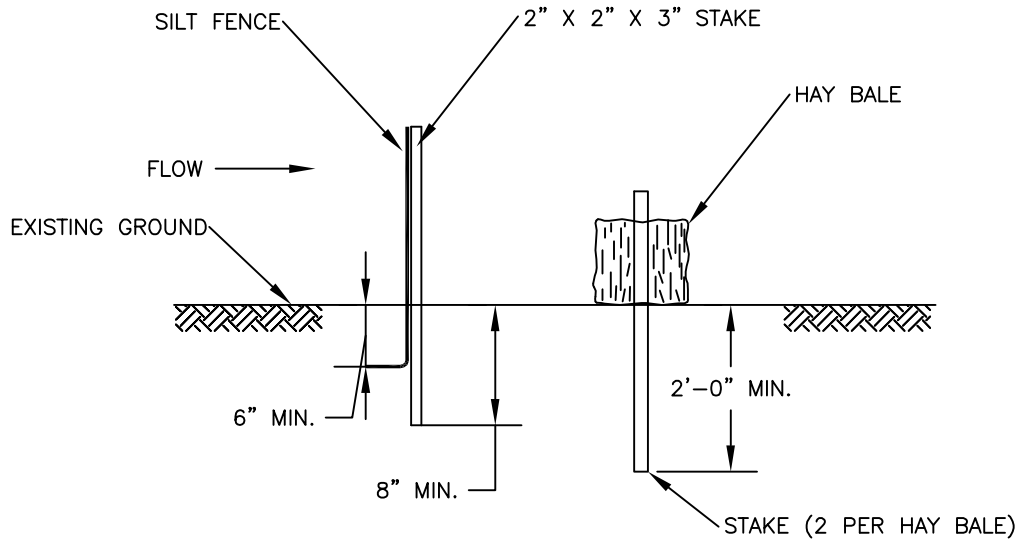

SECTION A-A

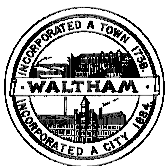
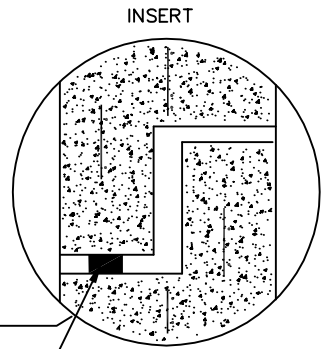
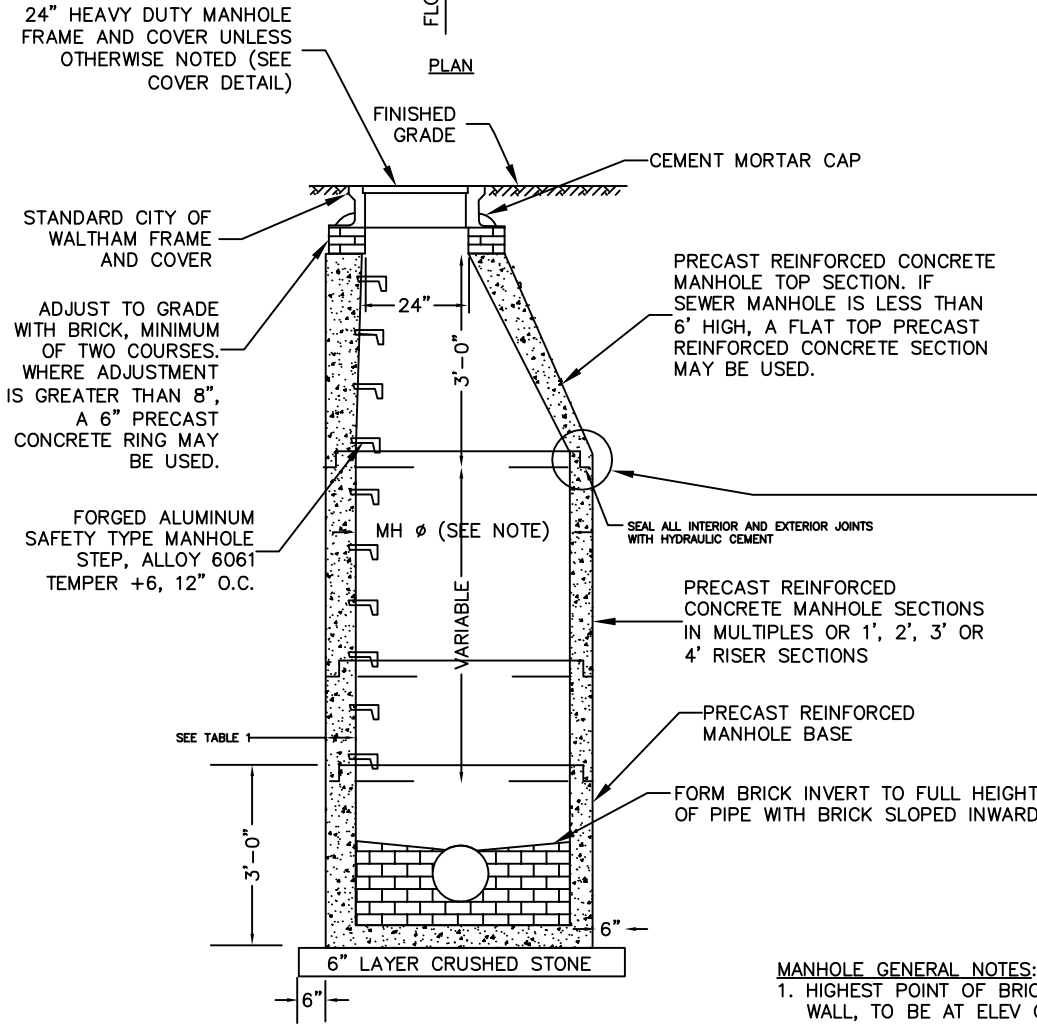
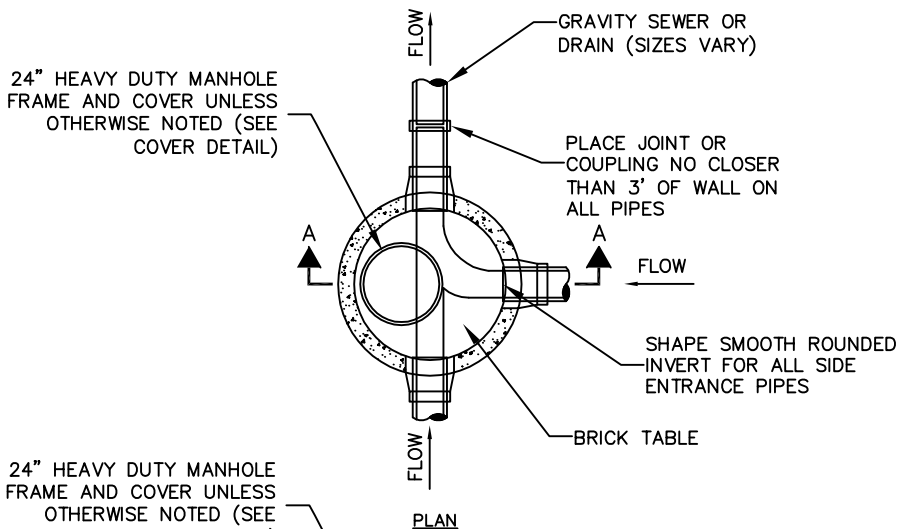

FIGURE NAME:  
199.000.A – HAY BALE FOR EROSION CONTROL

CITY OF WALTHAM, MA. – ENGINEERING DEPARTMENT  
STANDARD DETAILS

SCALE:  
NOT TO SCALE

REV. DATE:  
12/8/2010 358



SECTION A-A  
STANDARD MUNICIPAL MANHOLE

- MANHOLE GENERAL NOTES:**
- HIGHEST POINT OF BRICK TABLE AT MANHOLE WALL, TO BE AT ELEV OF CROWN OF PIPE. TABLE TO SLOPE AT 8.3%.
  - SEWER OR DRAIN MANHOLE DIAMETER SHALL BE 4', 5', 6', 8' OR 10' AS SHOWN ON PLAN/PROFILE VIEWS.
  - DESIGN PRECAST SECTIONS WITH FRAME AND COVER FOR AASHTO H20 LOADINGS. UNLESS OTHERWISE NOTED
  - PRECAST MANHOLES SHALL BE PRE-ORDERED WITH PENETRATIONS AT ELEVATIONS INDICATED ON CONTRACT DRAWINGS.

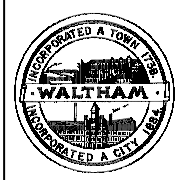
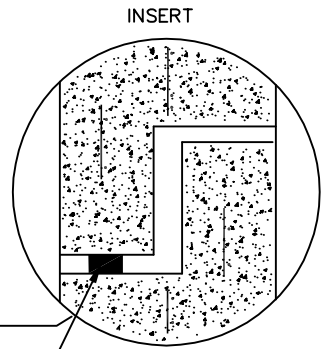
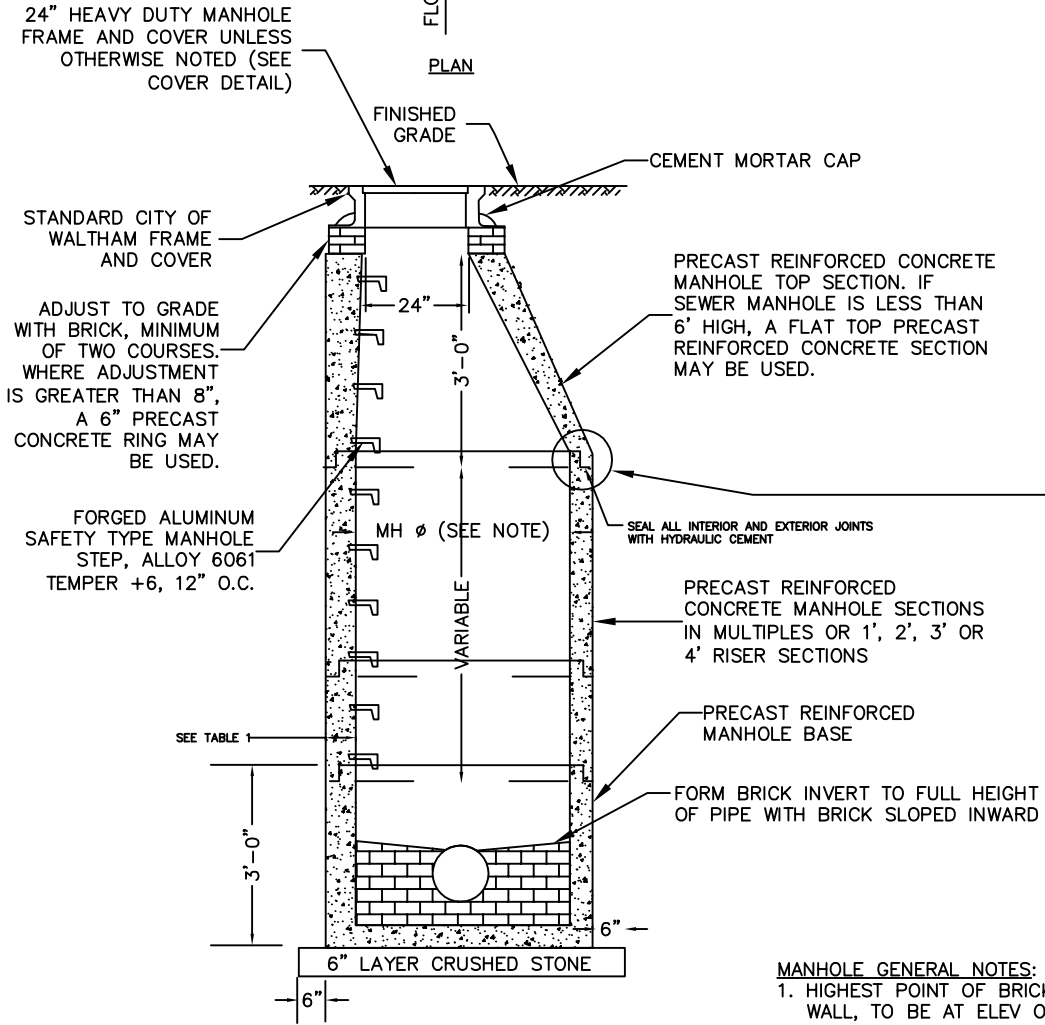
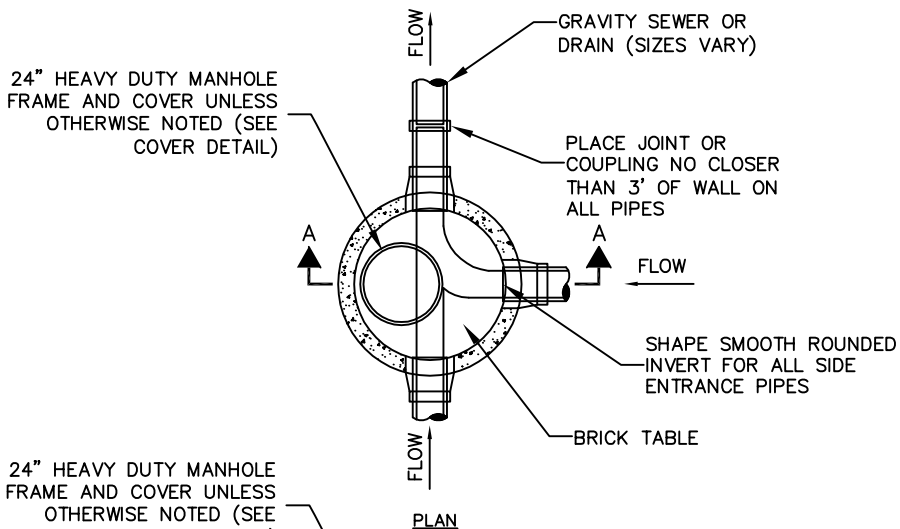

FIGURE NAME:  
202.000.B – STANDARD MUNICIPAL MANHOLE DETAIL

CITY OF WALTHAM, MA. – ENGINEERING DEPARTMENT  
STANDARD DETAILS

SCALE:  
NOT TO SCALE

REV. DATE:  
12/8/2010 359



SECTION A-A  
STANDARD MUNICIPAL MANHOLE

- MANHOLE GENERAL NOTES:**
- HIGHEST POINT OF BRICK TABLE AT MANHOLE WALL, TO BE AT ELEV OF CROWN OF PIPE. TABLE TO SLOPE AT 8.3%.
  - SEWER OR DRAIN MANHOLE DIAMETER SHALL BE 4', 5', 6', 8' OR 10' AS SHOWN ON PLAN/PROFILE VIEWS.
  - DESIGN PRECAST SECTIONS WITH FRAME AND COVER FOR AASHTO H20 LOADINGS. UNLESS OTHERWISE NOTED.
  - PRECAST MANHOLES SHALL BE PRE-ORDERED WITH PENETRATIONS AT ELEVATIONS INDICATED ON CONTRACT DRAWINGS.

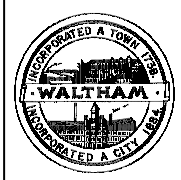

FIGURE NAME:  
202.000.B – STANDARD MUNICIPAL MANHOLE DETAIL

CITY OF WALTHAM, MA. – ENGINEERING DEPARTMENT  
STANDARD DETAILS

SCALE:  
NOT TO SCALE

REV. DATE:  
12/8/2010 360



## **Appendix “C” – List of properties and Summary of Field Inspection Findings**

**City of Waltham, MA  
Sump Pump Amnesty Program  
Contract 2 - Areas 5B, 5D and 15**

**List of Property Addresses**

Count	Address Number	Street Name	Findings
1	4	Allen Road	Sump pump discharges to sewer.
2	50	Amherst Avenue	Sump pump has never been used, but resident hooks it up to sewer when there are threats of heavy rain.
3	74	Amherst Avenue	Sump pump discharges to sewer.
4	48	Barbara Road	Sump pump discharges to sewer.
5	26	Bruce Road	Sump pump discharges to sewer.
6	43	Chesterbrook Avenue	Sump pump discharges to sewer.
7	46	College Farm Road	Sump pump discharges to sewer.
8	26	Glen Circle	2 Sump pumps - both discharge to sewer.
9	25	Hagar Lane	Sump pump discharges to sewer.
10	19	Hagar Lane	Sump pump discharges to sewer.
11	28	Hibiscus Avenue	Sump pump discharges to sewer. Area drain in bulkhead also connected to sewer.
12	63	Indian Road	Sump pump discharges to sewer.
13	86	Indian Road	Sump pump discharges to sewer.
14	89	Indian Road	Sump pump discharges to sewer.
15	26	Lake Street	Sump pump discharges to sewer.
16	78	Lake Street	Sump pump discharges to sewer.
17	103	Lake Street	Sump pump discharges to sewer.
18	120	Lake Street	Sump pump discharges to sewer.
19	126	Lake Street	Sump pump discharges to sewer. Into sink
20	133	Lake Street	Sump pump discharges to sewer.
21	48	Lakeview Terrace	Sump pump discharges to sewer.
22	52	Lakeview Terrace	Sump pump discharges to sewer.
23	53	Lakeview Terrace	Sump pump discharges to sewer.
24	59	Lakeview Terrace	Sump pump discharges to sewer.
25	60	Lakeview Terrace	Sump pump discharges to sewer.
26	69	Lakeview Terrace	Sump pump discharges to sewer.

27	75	Lakeview Terrace	Sump pump discharges to sewer.
28	76	Lakeview Terrace	Sump pump discharges to sewer.
29	598	Lexington Street	Sump pump discharges to sewer. Into sink
30	468	Lincoln Street	Sump pump discharges to sewer.
31	100	Longfellow Road	Sump pump discharges to sewer
32	160	Longfellow Road	Sump pump discharges to sewer
33	14	Mokema Avenue	Area drain in driveway discharges to sewer.
34	47	Mokema Avenue	Sump pump discharges to sewer.
35	107	Mokema Avenue	Sump pump discharges to sewer.
36	50	Mount Walley Road	Sump pump discharges to sewer.
37	67	Mount Walley Road	Check Valve in Sump pit to sanitary.
38	11	Nutting Road	Sump pump discharges to sewer
39	43	Overlook Road	Sump pump discharges to sewer.
40	88	Princeton Avenue	Sump pump discharges to sewer
41	95	Princeton Avenue	Sump pump discharges to sewer.
42	98	Princeton Avenue	Sump pump discharges to sewer
43	104	Princeton Avenue	Sump pump discharges to sewer.
44	105	Princeton Avenue	Sump pump discharges to sewer.
45	33	Seminole Avenue	Sump pupm discharges to sewer.
46	49	Seminole Avenue	Sump pump was initially compliant, but resident called back after second re-flyering saying pump was hooked up to sewer.
47	26	Shore Road	Sump pump discharges to sewer.
48	71	Stone Road	Sump pump discharges to sewer.
49	61	Stone Road	Sump pump discharges to sewer.
50	88	Trimount Avenue	Sump pump discharges to sewer.
51	101	Trimount Avenue	3 sump pumps - 2 non-compliant and discharge to sewer.
52	6	Wampum Avenue	Sump pump discharges to sewer.
53	8	Wampum Avenue	Sump pump discharges to sewer
54	205	Warren Street	Sump pump discharges to sewer.
55	78	Whitman Road	Sump pump discharges to sewer.
56	84	Whitman Road	Sump pump discharges to sewer.

## **Appendix “D” – Wetland Resource, Area Maps**

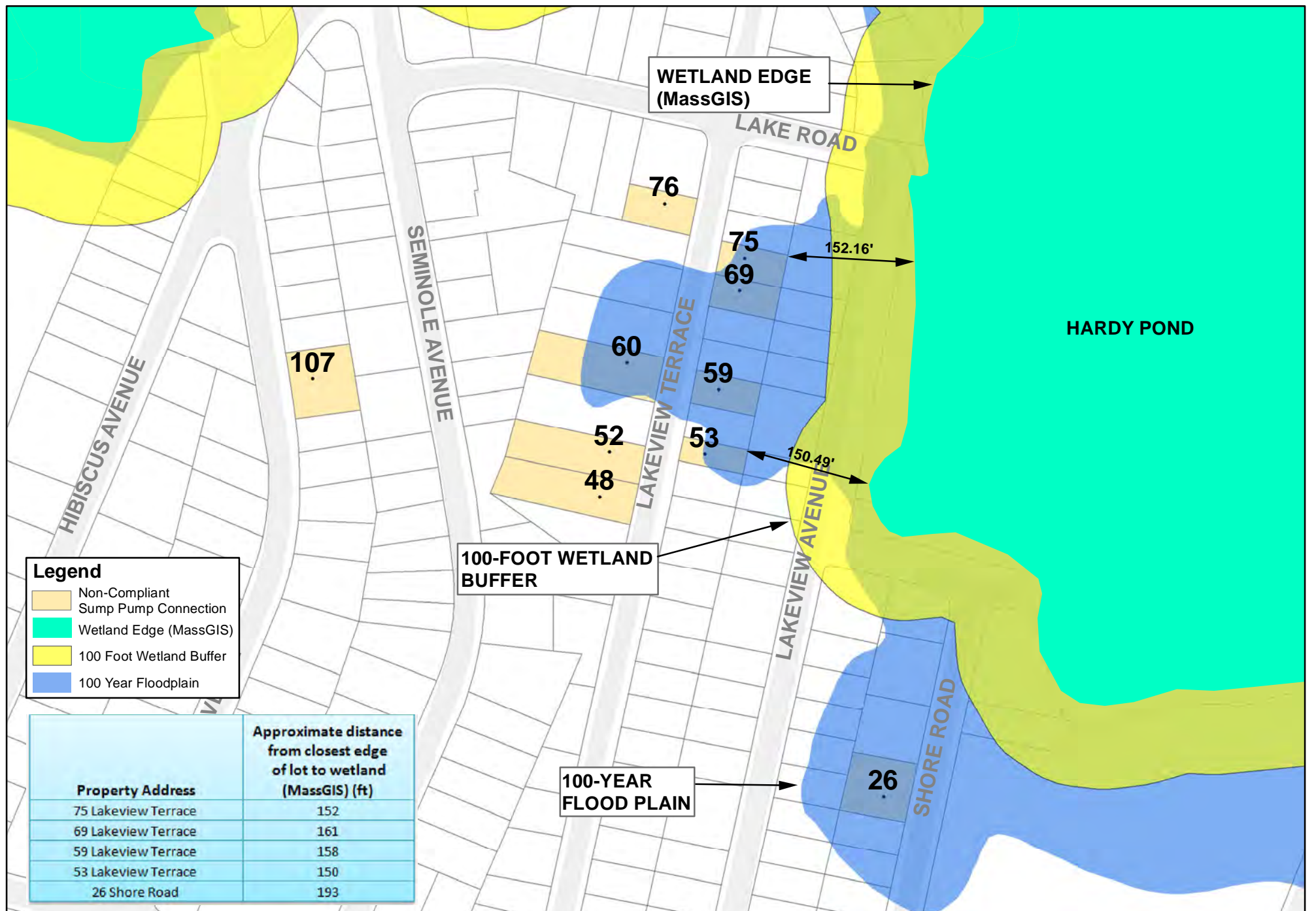

# CITY OF WALTHAM - SUMP PUMP AMNESTY PROGRAM AREAS 5B & 5D - WETLAND RESOURCE AREAS

1 inch = 150 feet



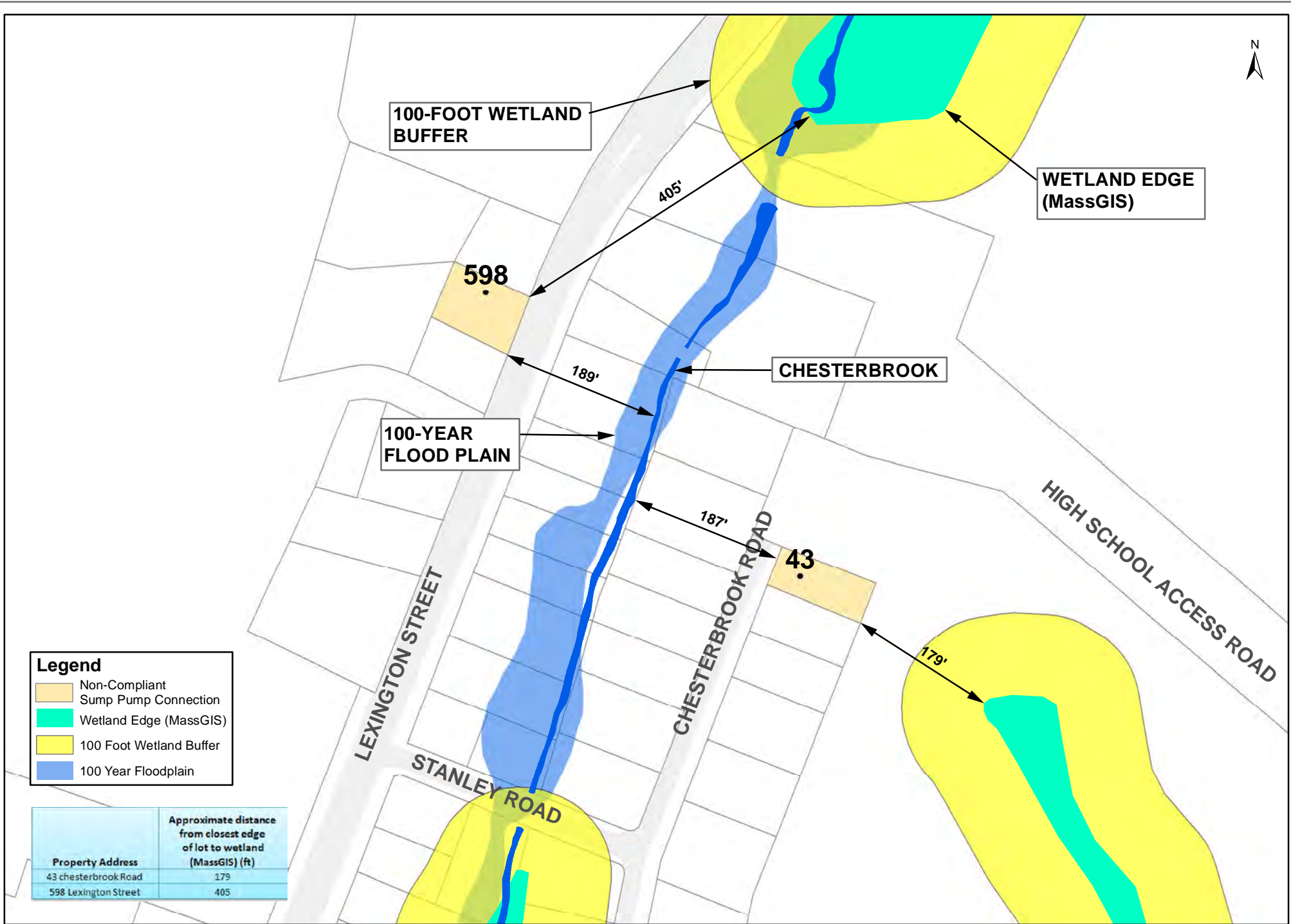

**Legend**

- Non-Compliant Sump Pump Connection
- Wetland Edge (MassGIS)
- 100 Foot Wetland Buffer
- 100 Year Floodplain

Property Address	Approximate distance from closest edge of lot to wetland (MassGIS) (ft)
43 chesterbrook Road	179
598 Lexington Street	405

**CITY OF WALTHAM - SUMP PUMP AMNESTY PROGRAM  
AREAS 5B & 5D - WETLAND RESOURCE AREAS**

1 inch = 150 feet



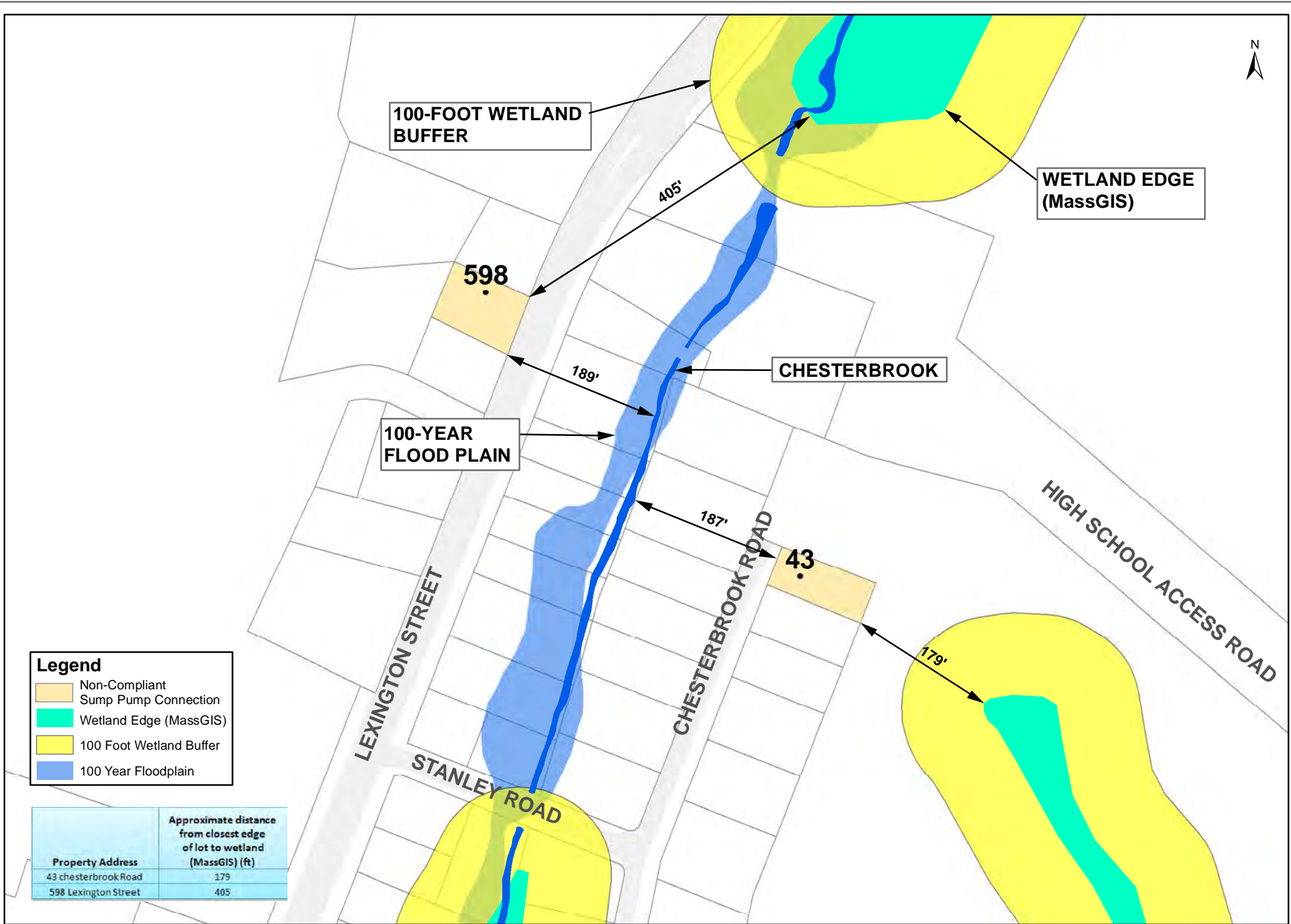

100-FOOT WETLAND BUFFER

WETLAND EDGE (MassGIS)

598

CHESTERBROOK

100-YEAR FLOOD PLAIN

HIGH SCHOOL ACCESS ROAD

CHESTERBROOK ROAD

43

LEXINGTON STREET

STANLEY ROAD

**Legend**

- Non-Compliant Sump Pump Connection
- Wetland Edge (MassGIS)
- 100 Foot Wetland Buffer
- 100 Year Floodplain

Property Address	Approximate distance from closest edge of lot to wetland (MassGIS) (ft)
43 chesterbrook Road	179
598 Lexington Street	405

**CITY OF WALTHAM - SUMP PUMP AMNESTY PROGRAM  
AREAS 5B & 5D - WETLAND RESOURCE AREAS**

1 inch = 150 feet



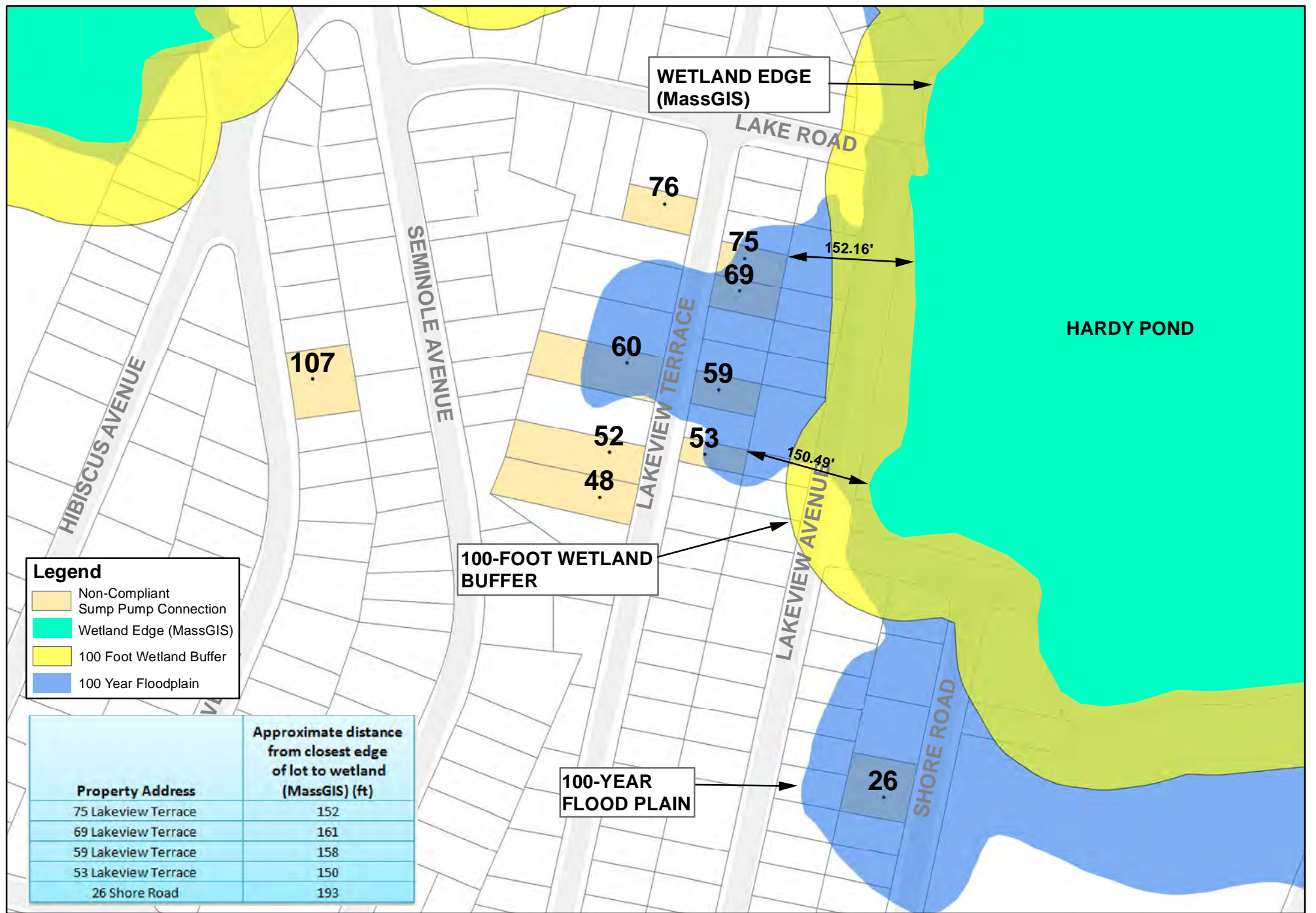

# CITY OF WALTHAM - SUMP PUMP AMNESTY PROGRAM AREAS 5B & 5D - WETLAND RESOURCE AREAS

1 inch = 150 feet





## **Appendix “E” – Photographs of Properties**

50 Amherst Ave



74 Amherst Ave



43 Chesterbrook Ave



46 College Farm Rd



26 Glen Circle



28 Hibiscus Ave



63 Indian Rd





86 Indian Rd



89 Indian Rd



26 Lake St



78 Lake St



103 Lake St



120 Lake St

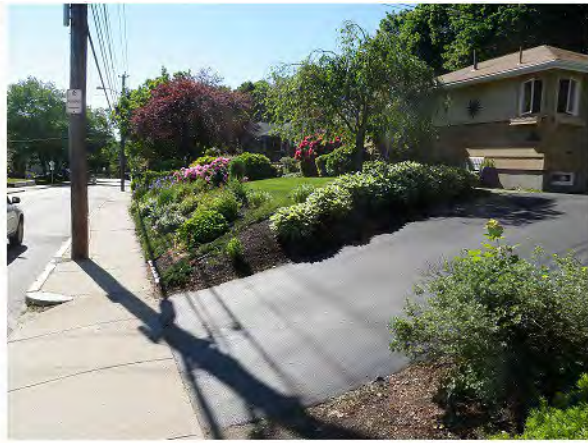
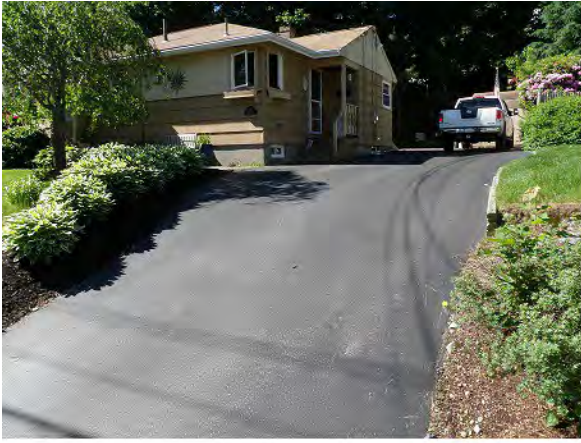

126 Lake St



133 Lake St

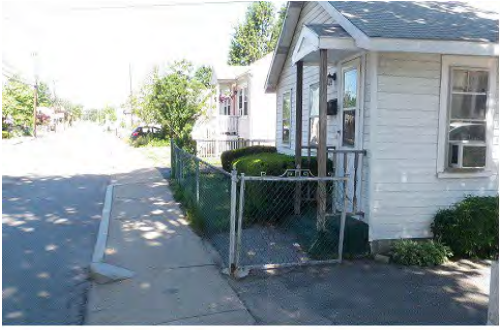



48 Lakeview Terrace

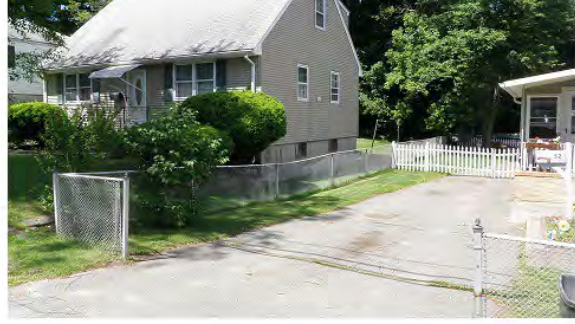

52 Lakeview Terrace



53 Lakeview Terrace

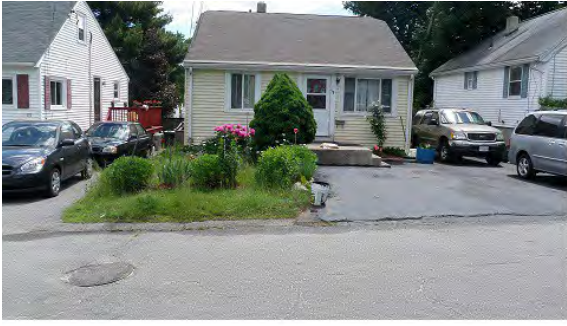

59 Lakeview Terrace



60 Lakeview Terrace



69 Lakeview Terrace



75 Lakeview Terrace



76 Lakeview Terrace





598 Lexington St



468 Lincoln St



14 Mokema Ave



33 Mokema Ave



47 Mokema Ave



107 Mokema Ave



18 Mt Walley



50 Mt Walley





67 Mt Walley



11 Nutting Ave



43 Overlook Rd.



88 Princeton Ave

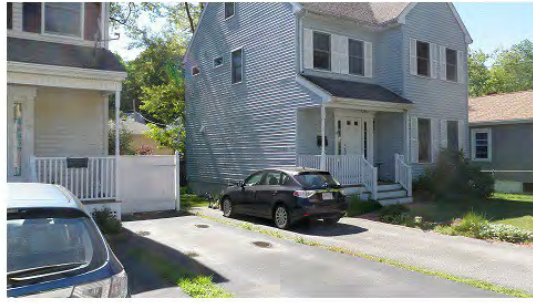

95 Princeton Ave

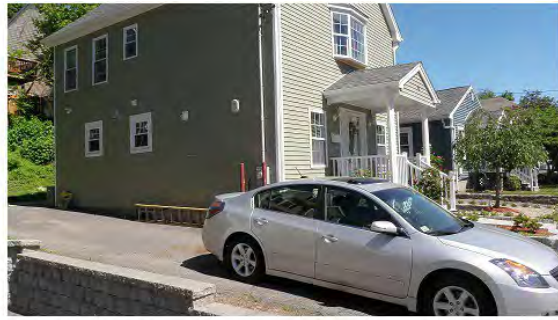

98 Princeton Ave



104 Princeton Ave



49 Seminole Ave





22 Shore Rd



26 Shore Rd



88 Trimont Ave



101 Trimont Ave



6 Wampum Ave.



8 Wampum



16 Wampum Ave



160 Longfellow Road





**78 Whitman Road**



84 Whitman Road



**100 Longfellow Road**



25 Hagar Lane



19 Hagar Lane



61 Stone Road



71 Stone Road



26 Bruce Road





48 Barbara Road



205 Warren Street



4 Allen Road



**Appendix “F” – Prevailing Wage Schedule** (will be found at [www.city.waltham.ma.us/open-bids](http://www.city.waltham.ma.us/open-bids) )

## **Appendix “G” – Waltham Conservation Commission Requirements**

JUL 01 2013

WALTHAM  
ENGINEERING DEPT.



Massachusetts Department of Environmental Protection  
Bureau of Resource Protection - Wetlands  
**WPA Form 2 – Determination of Applicability**  
Massachusetts Wetlands Protection Act M.G.L. c. 131, §40

**A. General Information**

**Important:**  
When filling out forms on the computer, use only the tab key to move your cursor - do not use the return key.



From:

City of Waltham  
Conservation Commission

To: Applicant

City of Waltham, Engineering Department  
Name  
119 School Street, Room 10  
Mailing Address

Waltham MA 02451  
City/Town State Zip Code

Property Owner (if different from applicant):

Name

Mailing Address

City/Town State Zip Code

1. Title and Date (or Revised Date if applicable) of Final Plans and Other Documents:

Title	Date
Title	Date
Title	Date

2. Date Request Filed:

6-17-13

**B. Determination**

Pursuant to the authority of M.G.L. c. 131, § 40, the Conservation Commission considered your Request for Determination of Applicability, with its supporting documentation, and made the following Determination.

Project Description (if applicable):

Disconnecting flows from residential sump pumps from the existing sanitary sewers and connecting to either an on-site infiltration system or the existing storm drain system.

Project Location:

Various Residential Property Owners  
Street Address

Waltham  
City/Town

Assessors Map/Plat Number

Parcel/Lot Number

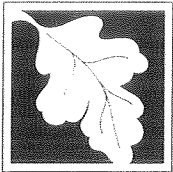

## WPA Form 2 – Determination of Applicability

Massachusetts Wetlands Protection Act M.G.L. c. 131, §40

### B. Determination (cont.)

The following Determination(s) is/are applicable to the proposed site and/or project relative to the Wetlands Protection Act and regulations:

#### Positive Determination

Note: No work within the jurisdiction of the Wetlands Protection Act may proceed until a final Order of Conditions (issued following submittal of a Notice of Intent or Abbreviated Notice of Intent) or Order of Resource Area Delineation (issued following submittal of Simplified Review ANRAD) has been received from the issuing authority (i.e., Conservation Commission or the Department of Environmental Protection).

1. The area described on the referenced plan(s) is an area subject to protection under the Act. Removing, filling, dredging, or altering of the area requires the filing of a Notice of Intent.

2a. The boundary delineations of the following resource areas described on the referenced plan(s) are confirmed as accurate. Therefore, the resource area boundaries confirmed in this Determination are binding as to all decisions rendered pursuant to the Wetlands Protection Act and its regulations regarding such boundaries for as long as this Determination is valid.

2b. The boundaries of resource areas listed below are not confirmed by this Determination, regardless of whether such boundaries are contained on the plans attached to this Determination or to the Request for Determination.

3. The work described on referenced plan(s) and document(s) is within an area subject to protection under the Act and will remove, fill, dredge, or alter that area. Therefore, said work requires the filing of a Notice of Intent.

4. The work described on referenced plan(s) and document(s) is within the Buffer Zone and will alter an Area subject to protection under the Act. Therefore, said work requires the filing of a Notice of Intent or ANRAD Simplified Review (if work is limited to the Buffer Zone).

5. The area and/or work described on referenced plan(s) and document(s) is subject to review and approval by:

\_\_\_\_\_  
Name of Municipality

\_\_\_\_\_  
Pursuant to the following municipal wetland ordinance or bylaw:

\_\_\_\_\_  
Name

\_\_\_\_\_  
Ordinance or Bylaw Citation

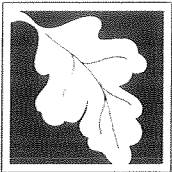

Massachusetts Department of Environmental Protection  
Bureau of Resource Protection - Wetlands  
**WPA Form 2 – Determination of Applicability**  
Massachusetts Wetlands Protection Act M.G.L. c. 131, §40

---

**B. Determination (cont.)**

6. The following area and/or work, if any, is subject to a municipal ordinance or bylaw but not subject to the Massachusetts Wetlands Protection Act:

- 
7. If a Notice of Intent is filed for the work in the Riverfront Area described on referenced plan(s) and document(s), which includes all or part of the work described in the Request, the applicant must consider the following alternatives. (Refer to the wetland regulations at 10.58(4)c. for more information about the scope of alternatives requirements):

- Alternatives limited to the lot on which the project is located.
- Alternatives limited to the lot on which the project is located, the subdivided lots, and any adjacent lots formerly or presently owned by the same owner.
- Alternatives limited to the original parcel on which the project is located, the subdivided parcels, any adjacent parcels, and any other land which can reasonably be obtained within the municipality.
- Alternatives extend to any sites which can reasonably be obtained within the appropriate region of the state.

**Negative Determination**

Note: No further action under the Wetlands Protection Act is required by the applicant. However, if the Department is requested to issue a Superseding Determination of Applicability, work may not proceed on this project unless the Department fails to act on such request within 35 days of the date the request is post-marked for certified mail or hand delivered to the Department. Work may then proceed at the owner's risk only upon notice to the Department and to the Conservation Commission. Requirements for requests for Superseding Determinations are listed at the end of this document.

1. The area described in the Request is not an area subject to protection under the Act or the Buffer Zone.
2. The work described in the Request is within an area subject to protection under the Act, but will not remove, fill, dredge, or alter that area. Therefore, said work does not require the filing of a Notice of Intent.
3. The work described in the Request is within the Buffer Zone, as defined in the regulations, but will not alter an Area subject to protection under the Act. Therefore, said work does not require the filing of a Notice of Intent, subject to the following conditions (if any).  
1. Restore properties in buffer zone to condition that they were prior to work 2. Reasonable precautions to prevent erosion. 3. Use straw wattles. 4. No use of phosphorus.

- 
4. The work described in the Request is not within an Area subject to protection under the Act (including the Buffer Zone). Therefore, said work does not require the filing of a Notice of Intent, unless and until said work alters an Area subject to protection under the Act.





Massachusetts Department of Environmental Protection  
 Bureau of Resource Protection - Wetlands  
**WPA Form 2 – Determination of Applicability**  
 Massachusetts Wetlands Protection Act M.G.L. c. 131, §40

**B. Determination (cont.)**

5. The area described in the Request is subject to protection under the Act. Since the work described therein meets the requirements for the following exemption, as specified in the Act and the regulations, no Notice of Intent is required:

Exempt Activity (site applicable statutory/regulatory provisions)

6. The area and/or work described in the Request is not subject to review and approval by:

Name of Municipality

Pursuant to a municipal wetlands ordinance or bylaw.

Name

Ordinance or Bylaw Citation

**C. Authorization**

This Determination is issued to the applicant and delivered as follows:

by hand delivery on

by certified mail, return receipt requested on

Date

Date

7/1/13

This Determination is valid for **three years** from the date of issuance (except Determinations for Vegetation Management Plans which are valid for the duration of the Plan). This Determination does not relieve the applicant from complying with all other applicable federal, state, or local statutes, ordinances, bylaws, or regulations.

This Determination must be signed by a majority of the Conservation Commission. A copy must be sent to the appropriate DEP Regional Office (see <http://www.mass.gov/dep/about/region.findyour.htm>) and the property owner (if different from the applicant).

Signatures:

*Lesya Song*  
*James W. Kelley*

*M. D. Fowl*

Date

7/1/13



**Massachusetts Department of Environmental Protection**

Bureau of Resource Protection - Wetlands

**WPA Form 2 – Determination of Applicability**

Massachusetts Wetlands Protection Act M.G.L. c. 131, §40

---

**D. Appeals**

The applicant, owner, any person aggrieved by this Determination, any owner of land abutting the land upon which the proposed work is to be done, or any ten residents of the city or town in which such land is located, are hereby notified of their right to request the appropriate Department of Environmental Protection Regional Office (see <http://www.mass.gov/dep/about/region.findyour.htm>) to issue a Superseding Determination of Applicability. The request must be made by certified mail or hand delivery to the Department, with the appropriate filing fee and Fee Transmittal Form (see Request for Departmental Action Fee Transmittal Form) as provided in 310 CMR 10.03(7) within ten business days from the date of issuance of this Determination. A copy of the request shall at the same time be sent by certified mail or hand delivery to the Conservation Commission and to the applicant if he/she is not the appellant. The request shall state clearly and concisely the objections to the Determination which is being appealed. To the extent that the Determination is based on a municipal ordinance or bylaw and not on the Massachusetts Wetlands Protection Act or regulations, the Department of Environmental Protection has no appellate jurisdiction.



**Massachusetts Department of Environmental Protection**

Bureau of Resource Protection - Wetlands

**Request for Departmental Action Fee Transmittal Form**

Massachusetts Wetlands Protection Act M.G.L. c. 131, §40

**A. Request Information**

**Important:**  
When filling out forms on the computer, use only the tab key to move your cursor - do not use the return key.



1. Person or party making request (if appropriate, name the citizen group's representative):

Name

Mailing Address

City/Town

State

Zip Code

Phone Number

Fax Number (if applicable)

Project Location

Mailing Address

City/Town

State

Zip Code

2. Applicant (as shown on Notice of Intent (Form 3), Abbreviated Notice of Resource Area Delineation (Form 4A); or Request for Determination of Applicability (Form 1)):

Name

Mailing Address

City/Town

State

Zip Code

Phone Number

Fax Number (if applicable)

3. DEP File Number:

**B. Instructions**

1. When the Departmental action request is for (check one):

- Superseding Order of Conditions (\$100 for individual single family homes with associated structures; \$200 for all other projects)
- Superseding Determination of Applicability (\$100)
- Superseding Order of Resource Area Delineation (\$100)

Send this form and check or money order for the appropriate amount, payable to the *Commonwealth of Massachusetts* to:

Department of Environmental Protection  
Box 4062  
Boston, MA 02211



**Massachusetts Department of Environmental Protection**

Bureau of Resource Protection - Wetlands

**Request for Departmental Action Fee Transmittal Form**

Massachusetts Wetlands Protection Act M.G.L. c. 131, §40

---

**B. Instructions (cont.)**

2. On a separate sheet attached to this form, state clearly and concisely the objections to the Determination or Order which is being appealed. To the extent that the Determination or Order is based on a municipal bylaw, and not on the Massachusetts Wetlands Protection Act or regulations, the Department has no appellate jurisdiction.
3. Send a **copy** of this form and a **copy** of the check or money order with the Request for a Superseding Determination or Order by certified mail or hand delivery to the appropriate DEP Regional Office (see <http://www.mass.gov/dep/about/region/findyour.htm>).
4. A copy of the request shall at the same time be sent by certified mail or hand delivery to the Conservation Commission and to the applicant, if he/she is not the appellant.