

The City of Waltham

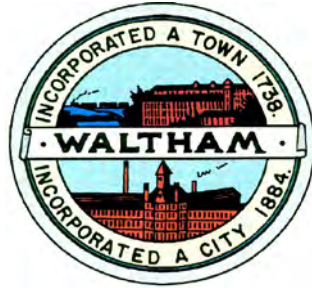

**Invites
Interested Parties
To propose the best offer and or bid
For the service or product herewith described:**

**RESURFACING OF BITUMINOUS ROADWAYS AND REPAIRS TO
SIDEWALKS, 2015-2016**

The bid opening will be held: **Wednesday July 29, 2015 at 10:00 am**

Last day for written questions: **12.00 noon Tuesday July 21, 2015**

(To jpedulla@city.waltham.ma.us)

Note:

- 1) Chapter 90 funded projects with a value of \$50,000 or greater: Subject to the requirements of Chapter 29 Section 8B of the Massachusetts General Laws, each prospective bidder proposing to bid on work to be awarded by a municipality under the provisions of section 34 chapter 90 must be prequalified in accordance with 720 CMR 5.00, "Prequalification of Contractors." The contractor must present this approval form to the Chief Procurement Officer at the time of the pre-bid meeting.**
- 2) Your company shall be prequalified by Mass DOT. Please submit with your bid response the Mass DOT prequalification record.**
- 3) Please provide the information requested by completely filling out fill out all forms and submit them with your price sheet.**

**CITY OF WALTHAM, MASSACHUSETTS
CONSOLIDATED PUBLIC WORKS DEPARTMENT**

**ANNUAL CONTRACT FOR
RESURFACING OF BITUMINOUS ROADWAYS AND REPAIRS TO SIDEWALKS
IN
WALTHAM, MASSACHUSETTS**

TABLE OF CONTENTS

1. Invitation to Bid.....	1-1
2A. Resident Employment Construction program.....	2A
2B. City of Waltham and Federal AA/EEO requirements and labor standards, including wage rates.....	Section 2B
3. Bid	3-1
4. Contract.....	4-1
5A. Payment Bonds	5-1
5B. Performance Bond	5-B
5C. Compliance.....	5-C
6. General Specifications.....	6-1
6A. Instructions to bidders.....	6-A
6B. General Conditions.....	6-B
7. Technical Provisions	7-1
8. Miscellaneous Detail Drawings and documents.....	Section 8

CITY OF WALTHAM, MASSACHUSETTS
CONSOLIDATED PUBLIC WORKS DEPARTMENT

1 – INVITATION TO BID
FOR
ANNUAL CONTRACT FOR
RESURFACING OF BITUMINOUS ROADWAYS AND REPAIRS TO SIDEWALKS
IN
WALTHAM, MASSACHUSETTS

SEALED BIDS for ANNUAL CONTRACT FOR RESURFACING OF BITUMINOUS ROADWAYS AND REPAIRS TO SIDEWALKS will be received by Joseph Pedulla, Chief Procurement Officer, City Hall, 610 Main street Waltham, Massachusetts until **Wednesday July 29, 2015 at 10:00 am** at which time they will be publicly opened and read.

BIDS shall be received only on the Bid forms provided, properly filled out and placed in a sealed envelope addressed to the Purchasing Agent, Waltham, Massachusetts, and endorsed "BID FOR ANNUAL CONTRACT FOR RESURFACING OF BITUMINOUS ROADWAYS AND REPAIRS TO SIDEWALKS" along with the bidder's name.

No Bid will be received unless accompanied by cash or treasurer's check issued by a responsible bank or trust company, or a bid bond for the sum of five percent of the CONTRACTOR'S bid price in favor of the City of Waltham. Should the Bidder selected as the CONTRACTOR on any such work fail to execute the Contract within five days, Sundays and holidays excluded, from the date of mailing a notice to the undersigned at the address given below that the contract is ready for signature, the amount so received as a bid deposit from such bidder through his cash or treasurer's check issued by a responsible bank or trust company, or bid bond shall become and be the property of the said City of Waltham as liquidated damages; provided, that in the case of death, disability or other unforeseen circumstances affecting the bidder, such bid deposit may be returned to him. An award shall then be made to the next lowest responsible and eligible bidder thereon.

The right is reserved by the City of Waltham to reject any or all bids as may be deemed best for the interests of the City and the City of Waltham reserves the right to waive any informalities in the bidding.

The successful bidder will be required to furnish a performance bond and labor and materials payment bond of an approved surety company in an amount not less than the full amount of the Contract.

Specifications and blank Bid forms may be obtained at no charge by visiting the City of Waltham web site at www.city.waltham.ma.us/purchasing/index.html or by e-mail request to Joseph Pedulla at www.jp pedulla@city.waltham.ma.us

The successful bidder will be required to furnish a Certificate of Insurance, naming the City as Additional Insured, for General Liability and Vehicle Liability in the amount of \$1,000,000 per occurrence and \$1,000,000 in the aggregate and Worker's Compensation Insurance as prescribed by law.

Attention is called to the fact that minimum wage rates are established for the project as set forth in the Contract documents.

The City of Waltham Supplemental Equal Employment Opportunity, Anti-discrimination and Affirmative Action Program, including special provisions for participation by minority and women business enterprises, applies to this invitation for bids as well as the entire Compliance section.

All bidders are hereby notified that the City of Waltham Affirmative action requirements portion of these documents must be filled out prior to the award of the contract. They will be found in section 2B of these documents.

The successful bidder shall observe faithfully all statutory requirements and local ordinances.

The City of Waltham specifically reserves the right to delete from the Contract any of the items stipulated in the Bid should, in its opinion, such action be necessary. The City of Waltham further reserves the right, should funds be available, to add to the items stipulated in the Bid should, in its opinion, such actions be in the best interest of the City of Waltham.

These specifications include a complete set of bid forms which are for the convenience of the bidder and are not to be filled out, executed, or detached from these specifications. Separate copies of the bid forms are furnished for submitting bids.

**CITY OF WALTHAM, MASSACHUSETTS
CONSOLIDATED PUBLIC WORKS DEPARTMENT**

**3 - BID
FOR
ANNUAL CONTRACT FOR
RESURFACING OF BITUMINOUS ROADWAYS AND REPAIRS TO SIDEWALKS
IN
WALTHAM, MASSACHUSETTS**

TO: Mr. Joseph Pedulla, Chief Procurement Officer
CITY OF WALTHAM, MASSACHUSETTS

The undersigned, as bidder, hereby declares that he has carefully examined the specifications and provisions attached hereto, and that he proposes and agrees, if this Bid is accepted, that he will contract with the CITY OF WALTHAM in the form prescribed for the ANNUAL CONTRACT FOR RESURFACING OF BITUMINOUS ROADWAYS AND REPAIRS TO SIDEWALKS as herein specified and will provide therefore all necessary materials, labor, machinery and equipment, and will perform all the work in the manner prescribed and according to the requirements of the OWNER.

Accompanying this Bid is cash or a treasurer's check payable to the City of Waltham, or a Bid bond in the amount of five percent of the CONTRACTOR'S Bid price

If this Bid shall be accepted and the undersigned shall fail to execute the required contract, in accordance with the terms herein set forth, within five days from the date of mailing a notice to the undersigned at the address given below that the contract is ready for signature, the City of Waltham may, at its option, determine that this Bid shall be null and void, and the aforesaid cash or checks shall become the property of the City of Waltham; otherwise the said cash or checks shall be returned to the undersigned.

BIDDER ACKNOWLEDGES RECEIPT OF THE FOLLOWING ADDENDA:

The undersigned, as Bidder, hereby declares that he will take full payment thereof sums based on the following unit prices as applied to the various quantities ordered by the OWNER from time to time during the life of this contract.

SECTION 2A

CITY OF WALTHAM
RESIDENTS CONSTRUCTION EMPLOYMENT PROGRAM

Please see City of Waltham Ordinances.

SECTION 2B

CITY OF WALTHAM AND FEDERAL EQUAL OPPORTUNITY AND AFFIRMATIVE ACTION REQUIREMENTS

INCLUDING WAGE RATES (please see end of bid document)

The City Of Waltham Equal Employment Opportunity And Affirmative Action Policy

The City of Waltham is committed to a policy of equal employment opportunity and to a program of affirmative action in order to fulfill that policy. The City will accordingly recruit and hire into all positions the most qualified persons in light of job-related requirements, and applicants and employees shall be treated in employment matters without regard to unlawful criteria including race, color, religion, ancestry, national origin, sex, sexual orientation, disability, age, positive HIV-related blood test results, status as a disabled or Vietnam Era Veteran, genetic information, or gender identity or expression, as these terms are defined under applicable law, or any other factor or characteristic protected by law.

In addition, The City of Waltham recognizes that discriminatory harassment and sexual harassment are forms of unlawful discrimination, and it is, therefore, the policy of the City of Waltham that discriminatory harassment and sexual harassment will not be tolerated. The City of Waltham also prohibits unlawful harassment on the basis of other characteristics protected by law.

Further, employees and applicants will not be subjected to harassment or retaliation because they have engaged in or may engage in the following: filing a complaint or assisting or participating in an investigation regarding alleged discrimination or harassment as prohibited in the policy statement above; filing a complaint or assisting or participating in an investigation, compliance evaluation, or any other activity related to the administration of the Vietnam Era Veterans' Readjustment Assistance Act of 1974 ("VEVRAA"), Section 503 of the Rehabilitation Act of 1973 ("Rehabilitation Act"), or the Affirmative Action provisions of federal, state or local law; opposing any act or practice made unlawful by VEVRAA requiring equal employment opportunities for individuals with disabilities, disabled veterans, or veterans of the Vietnam Era; or exercising any rights under VEVRAA or the Rehabilitation Act.

Sources: Titles VI and VII of the Civil Rights Act of 1964; the Immigration Reform and Control Act of 1986; Title IX of the Education Amendments of 1972; the Equal Pay Act of 1963; the Age Discrimination in Employment Act of 1967; the Age Discrimination Act of 1975; Sections 503 and 504 of the Rehabilitation Act of 1973; the Americans with Disabilities Act of 1990; Section 402 of the Vietnam-Era Veterans Readjustment Assistance Act of 1974; Executive Order 11246 as amended; The Genetic Information Nondiscrimination Act of 2008 and such other federal, state and local non-discrimination laws as may apply.

**CITY OF WALTHAM, MASSACHUSETTS
CONSOLIDATED PUBLIC WORKS DEPARTMENT**

Section 3 - BID
FOR
ANNUAL CONTRACT FOR
RESURFACING OF BITUMINOUS ROADWAYS AND REPAIRS TO SIDEWALKS, 2015
IN
WALTHAM, MASSACHUSETTS

TO: Mr. Joseph Pedulla, Chief Procurement Officer
CITY OF WALTHAM, MASSACHUSETTS

The undersigned, as bidder, hereby declares that he has carefully examined the specifications and provisions attached hereto, and that he proposes and agrees, if this Bid is accepted, that he will contract with the CITY OF WALTHAM in the form prescribed for the ANNUAL CONTRACT FOR RESURFACING OF BITUMINOUS ROADWAYS AND REPAIRS TO SIDEWALKS as herein specified and will provide therefore all necessary materials, labor, machinery and equipment, and will perform all the work in the manner prescribed and according to the requirements of the OWNER.

Accompanying this Bid is cash or a treasurer's check payable to the City of Waltham, or a Bid bond in the amount of five percent of the CONTRACTOR'S Bid price

If this Bid shall be accepted and the undersigned shall fail to execute the required contract, in accordance with the terms herein set forth, within five days from the date of mailing a notice to the undersigned at the address given below that the contract is ready for signature, the City of Waltham may, at its option, determine that this Bid shall be null and void, and the aforesaid cash or checks shall become the property of the City of Waltham; otherwise the said cash or checks shall be returned to the undersigned.

BIDDER ACKNOWLEDGES RECEIPT OF THE FOLLOWING ADDENDA:

The undersigned, as Bidder, hereby declares that he will take full payment thereof sums based on the following unit prices as applied to the various quantities ordered by the OWNER from time to time during the life of this contract.

It is understood and agreed that the quantities set forth in the Bid are provided for bid comparison only and the actual quantity of work to be done may vary, as determined by the OWNER. The CONTRACTOR agrees that he shall neither have nor assert any claim for or be entitled to any additional compensation for damages or for loss of anticipated profits on work that is eliminated.

The time for completion of work under this contract shall be one year from the date of the Notice to Proceed. The City of Waltham, at its sole option, may elect to extend the contract period for an additional year.

All unit prices quoted herein shall be firm for the duration of this Contract, regardless of any changes in the cost of materials and labor, with the exception of hot mix asphalt (HMA) mixtures, diesel fuel and gasoline, and Portland cement concrete mixtures. For monthly price adjustments for these items, refer to Mass Highway documents 00811, 00812 and 00814 respectively. Copies of these documents are included in section 8.

In accordance with Massachusetts General Laws, the undersigned certifies that the bidder has filed all state tax returns and paid all state taxes required by law.

In accordance with Massachusetts General Laws, the undersigned certifies that all employees to be employed at the worksite will have successfully completed a course in construction safety and health approved by OSHA that is at least 10 hours in duration at the time the employee begins work and shall furnish documentation of successful completion of said course with the first certified payroll report for each employee.

BIDDER

SIGNATURE

BUSINESS ADDRESS

TELEPHONE NUMBER

FAX NUMBER

EMAIL ADDRESS

DATE

PROOF OF CONTRACTOR'S RESPONSIBILITY

Before a contract will be awarded to any Bidder, he will be required to furnish evidence satisfactory to the OWNER that he has all of the following qualifications:

A. Ability, equipment, organization, and financial resources sufficient to enable him to construct and complete the work successfully within the time required.

B. Experience during the past three years in the successful construction of similar engineering projects, the magnitude of which shall be not less than one-half the work herein specified. In this connection, the attention of the Bidder is directed to the Bidder's experience form attached, that shall be used in determining the responsibility of the Bidder. The OWNER may require additional information whenever, in his judgment, such information is necessary to determine the responsibility of the Bidder.

An experienced Bidder shall be construed to mean that the Bidder has a minimum of three individuals within his organization that have the experience to supervise a job of this nature and magnitude. Their experience shall include previous work of a nature similar to the work prescribed in this contract.

In the event the Bidder fails, refuses, or neglects to submit any required information within the reasonable time stated in any request or fails to qualify as a responsible Bidder, his Bid guaranty shall be forfeited to the use of the OWNER, not as a penalty, but as liquidated damages.

The determination of whether a Bidder is responsible shall rest solely with the OWNER.

BIDDER'S EXPERIENCE

The following is a list of the projects similar in character and scope to the work specified in this contract that have been successfully completed by this Bidder during the past three years. "Completed" means the OWNER or authorized representative has accepted the project and final payment has been received. Each Bidder must furnish this information. If provided in a different format, all of the following information must be included.

LOCATION | TYPE OF WORK | DOLLAR VALUE | OWNER'S NAME AND ADDRESS | OWNER'S ENGINEER AND PHONE and DATE COMPLETED

_____ BIDDER'S SIGNATURE

CONTRACTORS ACKNOWLEDGMENT AND CONSENT TO PROVIDE MULTIPLE WORKING CREWS

The successful contractor is made aware that the City's paving schedule may be very busy particularly during the height of the paving season and at times delayed due to weather conditions. Therefore, the contractor agrees to provide to the City, with two(2) fully equipped working crews to meet the demand od a very busy street paving schedule

Company: _____

Authorized Signature: _____

Print Name: _____

Date: _____

102.000	5 EA	TREE PLANTING (2-INCH CALIPER PIN OAK) _____ PER EA	Unit Price	Extended Price
103.000	8 EA	TREE REMOVED (DIAMETER UNDER 24 INCHES) _____ PER EA	Unit Price	Extended Price
104.000	8 EA	TREE REMOVED (DIAMETER OVER 24 INCHES) _____ PER EA	Unit Price	Extended Price
105.000	16 EA	STUMP REMOVED _____ PER EA	Unit Price	Extended Price
120.100	2,225 CY	UNCLASSIFIED EXCAVATION _____ PER CY	Unit Price	Extended Price
127.000	575 SY	CEMENT CONCRETE EXCAVATION _____ PER SY	Unit Price	Extended Price
129.010	135,500 SY	COLD PLANING _____ PER SY	Unit Price	Extended Price
151.220	500 CY	GRAVEL BORROW FOR SIDEWALKS _____ PER CY	Unit Price	Extended Price

151.900	1,575 TN	CRUSHER RUN _____ PER TON	Unit Price	Extended Price
154.001	100 TN	SAND FOR RECLAMATION _____ PER TON	Unit Price	Extended Price
220.000	800 EA	DRAINAGE STRUCTURE ADJUSTED _____ EACH	Unit Price	Extended Price
220.500	175 VF	DRAINAGE STRUCTURE REMODELED _____ PER VERTICAL FOOT	Unit Price	Extended Price
222.010	30 EA	FRAME AND GRATE OR COVER (IN PLACE) _____ EACH	Unit Price	Extended Price
357.060	270 EA	6" SERVICE GATE BOX _____ EACH	Unit Price	Extended Price
358.100	275 EA	SIDEWALK GATE BOX ADJUSTED _____ EACH	Unit Price	Extended Price
358.200	340 EA	ROADWAY GATE BOX ADJUSTED _____ EACH	Unit Price	Extended Price

403.001	18,500 SY	ROADWAY RECLAMATION AND EXCAVATION _____ PER SQUARE YARD	Unit Price	Extended Price
405.000	100 SY	TRENCH REPAIR _____ PER SQUARE YARD	Unit Price	Extended Price
440.000	1,850 LB	CALCIUM CHLORIDE FOR DUST CONTROL _____ PER POUND	Unit Price	Extended Price
460.000	19,500 TN	CLASS I BITUMINOUS CONCRETE (TYPE I-1) (ROADWAY) _____ PER TON	Unit Price	Extended Price
460.100	4,500 TN	CLASS I BITUMINOUS CONCRETE (TYPE I-1) (SIDEWALKS, DRIVES, PERMANENT PATCHING) _____ PER TON	Unit Price	Extended Price
460.300	500 TN	CLASS I BITUMINOUS CONCRETE (TYPE I-1) (ROADWAY NIGHT WORK) _____ PER TON	Unit Price	Extended Price
464.000	9,000 GL	BITUMEN FOR TACK COAT _____ PER GALLON	Unit Price	Extended Price
470.000	3,200 LF	BITUMINOUS CONCRETE CURB (TYPE 2) _____ PER LINEAR FOOT	Unit Price	Extended Price

504.000	4,500 LF	GRANITE CURB TYPE VA-4 (STRAIGHT) _____ PER LINEAR FOOT	Unit Price	Extended Price
504.100	3,100 LF	GRANITE CURB TYPE VA-4 (CURVED) _____ PER LINEAR FOOT	Unit Price	Extended Price
516.000	5 EA	GRANITE CURB CORNER TYPE A (2' RADIUS) _____ EACH	Unit Price	Extended Price
517.000	5 EA	GRANITE CURB CORNER TYPE B (3' RADIUS) _____ EACH	Unit Price	Extended Price
520.000	2,200 LF	CONCRETE CURB (STRAIGHT) _____ PER LINEAR FOOT	Unit Price	Extended Price
520.100	350 LF	CONCRETE CURB (CURVED) _____ PER LINEAR FOOT	Unit Price	Extended Price
580.000	5,400 LF	CURB REMOVE AND RESET _____ PER LINEAR FOOT	Unit Price	Extended Price
701.050	2,150 SY	4" CEMENT CONCRETE SIDEWALK FIBERMESH REINFORCED _____ PER SQUARE YARD	Unit Price	Extended Price

701.150	4,650 SY	6" CEMENT CONCRETE SIDEWALK FIBERMESH REINFORCED _____ PER SQUARE YARD	Unit Price	Extended Price
702.000	300 EA	DETECTABLE TILE SURFACE FOR HANDICAP RAMPS _____ EACH	Unit Price	Extended Price
711.000	5 EA	STONE BOUND REMOVED AND RESET _____ EACH	Unit Price	Extended Price
711.100	5 EA	STONE BOUND FRAME AND COVER _____ EACH	Unit Price	Extended Price
751.000	2,150 CY	LOAM BORROW _____ PER CUBIC YARD	Unit Price	Extended Price
765.000	100 SY	SEEDING _____ PER SQUARE YARD	Unit Price	Extended Price
765.650	12,500 SY	HYDRO SEEDING _____ PER SQUARE YARD	Unit Price	Extended Price
801.300	100 LF	3" TRAFFIC CONDUIT _____ PER LINEAR FOOT	Unit Price	Extended Price

819.837	5,600 LF	LOOP DETECTORS WITH LEAD-IN WIRES _____ PER LINEAR FOOT	Unit Price	Extended Price
819.840	1 EA	TRAFFIC CAMERA _____ EACH	Unit Price	Extended Price
819.850	1 EA	TRAFFIC CAMERA RELATED EQUIPMENT _____ EACH	Unit Price	Extended Price
819.860	50 LF	SENSOR CABLE FOR TRAFFIC CAMERAS _____ PER LINEAR FOOT	Unit Price	Extended Price
850.221	3,000 SF	SAFETY SIGNING FOR CONSTRUCTION OPERATIONS _____ PER SQUARE FOOT	Unit Price	Extended Price
854.014	2,000 LF	TEMPORARY PAVEMENT MARKINGS – 4" PAINT _____ PER LINEAR FOOT	Unit Price	Extended Price
854.100	100 SF	PAVEMENT MARKINGS REMOVAL _____ PER SQUARE FOOT	Unit Price	Extended Price
864.040	3,000 SF	PAVEMENT ARROWS AND LEGENDS REFLECTORIZED WHITE THERMOPLASTIC _____ PER SQUARE FOOT	Unit Price	Extended Price

864.050	100 EA	SHARROW (PAINTED) _____ EACH	Unit Price	Extended Price
865.100	26,000 SF	CROSSWALKS AND STOP LINES REFLECTORIZED WHITE THERMOPLASTIC _____ PER SQUARE FOOT	Unit Price	Extended Price
868.040	44,000 LF	4" WHITE OR YELLOW REFLECTIVE THERMOPLASTIC LINE _____ PER LINEAR FOOT	Unit Price	Extended Price
870.000	175 DY	PORTABLE MESSAGE BOARD _____ PER DAY	Unit Price	Extended Price
999.001	\$250,000	TRAFFIC POLICE _____ DOLLAR FOR DOLLAR REIMBURSEMENT	\$1.00	\$250,000
	Total Bid price in figures:			
Total Bid price written in words:			\$	

It is understood that the City of Waltham makes no provision for the allowance of price escalation for any reason. It is the responsibility of the contractor to forecast such yearly increases, if any, and make allowances in the prices offered above.

It is understood and agreed that the quantities set forth in the Bid are provided for bid comparison only and the actual quantity of work to be done may vary, as determined by the OWNER. The CONTRACTOR agrees that he shall neither have nor assert any claim for or be entitled to any additional compensation for damages or for loss of anticipated profits on work that is eliminated.

The time for completion of work under this contract shall be one year from the date of the Notice to Proceed. The City of Waltham, at its sole option, may elect to extend the contract period for an additional year.

All unit prices quoted herein shall be firm for the duration of this Contract, regardless of any changes in the cost of materials and labor, with the exception of hot mix asphalt (HMA) mixtures, diesel fuel and gasoline, and Portland cement concrete mixtures. For monthly price adjustments for these items, refer to Mass Highway documents 00811, 00812 and 00814 respectively. Copies of these documents are included in section 8.

In accordance with Massachusetts General Laws, the undersigned certifies that the bidder has filed all state tax returns and paid all state taxes required by law.

In accordance with Massachusetts General Laws, the undersigned certifies that all employees to be employed at the worksite will have successfully completed a course in construction safety and health approved by OSHA that is at least 10 hours in duration at the time the employee begins work and shall furnish documentation of successful completion of said course with the first certified payroll report for each employee.

BIDDER

SIGNATURE

BUSINESS ADDRESS

TELEPHONE NUMBER

FAX NUMBER

EMAIL ADDRESS

DATE

CITY OF WALTHAM, MASSACHUSETTS
CONSOLIDATED PUBLIC WORKS DEPARTMENT

4 - CONTRACT
FOR
ANNUAL CONTRACT FOR
RESURFACING OF BITUMINOUS ROADWAYS AND REPAIRS TO SIDEWALKS
IN
WALTHAM, MASSACHUSETTS

CLAUSE 1. This agreement is made this _____ day of _____ in the year Two Thousand Fifteen (2015) by and between the City of Waltham, party of the first part, hereinafter called the CITY, by its MAYOR, and

_____ party of the second part, hereinafter called the CONTRACTOR.

CLAUSE 2. Witnesseth, that the parties to this agreement, each in consideration of the agreement on the part of the others herein contained, do hereby agree, the City of Waltham for itself, and said CONTRACTOR for his heirs, executors, administrators and assigns as follows:

The CONTRACTOR agrees to furnish all equipment, machinery, tools and labor, to furnish and deliver all materials required to be furnished (except as otherwise specified) and deliver in and about the project and to do and perform all work in ANNUAL CONTRACT FOR RESURFACING OF BITUMINOUS ROADWAYS AND REPAIRS TO SIDEWALKS and in strict conformity with the provisions of this contract and of the INVITATION TO BID, Bid and specifications hereto annexed. The said specifications and INVITATION TO BID are hereby made a part of this contract as fully and to the same effect as if the same had been set forth at length and incorporated in the contracts.

CLAUSE 3. In consideration of the foregoing promises the CITY agrees to pay and the CONTRACTOR agrees to receive as full compensation for everything furnished and done by the CONTRACTOR under this contract, including all work required but not included in the items herein mentioned, and for any unforeseen obstruction or difficulty encountered in the prosecution of the work, and for well and faithfully completing the work, and the whole thereof, as herein provided, such prices as are set forth in the accompanying bid.

CLAUSE 4: The time for completion of work under this contract shall be one year from the date of the Notice to Proceed. The City of Waltham, at its sole option, may elect to extend the contract period for an additional year.

It is understood and agreed that the quantities set forth in the Bid are approximate and the actual quantity of work to be done may be more or less, as determined by the OWNER. The CONTRACTOR agrees that he shall neither have nor assert any claim for or be entitled to any additional compensation for damages or for loss of anticipated profits on work that is eliminated.

FOR THE COMPANY

CITY OF WALTHAM, MASSACHUSETTS

<p>_____</p> <p>Authorized Corporate Signature, Date</p> <p>_____</p> <p>Name of Company,</p>	<p>_____</p> <p>Jeannette A. McCarthy, Mayor Date</p>
	<p>_____</p> <p>Joseph Pedulla, Purchasing Agent, Date</p>
	<p>_____</p> <p>Michael Chiasson, Director CPW, Date</p>
	<p>_____</p> <p>Luke Stanton, Asst. City Solicitor, Date (as to form only)</p>
	<p>_____</p> <p>Paul Centofanti, Auditor, Date (Certifies the availability of Funds)</p>

CITY OF WALTHAM, MASSACHUSETTS
CONSOLIDATED PUBLIC WORKS DEPARTMENT

5A - PAYMENT BOND
FOR
ANNUAL CONTRACT FOR
RESURFACING OF BITUMINOUS ROADWAYS AND REPAIRS TO SIDEWALKS
IN
WALTHAM, MASSACHUSETTS

KNOW ALL MEN BY THESE PRESENT, THAT

_____ AS PRINCIPAL AND
_____ AS SURETY

are held and firmly bound unto the CITY OF WALTHAM and to such persons, firms, and corporations, who may furnish materials for or perform labor on the work, construction or improvements contemplated in the Contract hereinafter mentioned, or who may have any suits or claims for injury or damage to persons or property resulting from or arising out of the work done under this Contract,

IN THE SUM OF _____ DOLLARS (\$ _____)
(lawful money of the United States of America) for the payment whereof the CONTRACTOR and the Surety of Sureties bind themselves and their heirs, executors, administrators, successors and assigns, jointly and severally, firmly by these presents.

THE CONDITION OF THIS OBLIGATION IS SUCH, that if the above bounden

heirs, executors, administrators and assigns, shall promptly make payment to all persons, firms, subcontractors, and corporations furnishing materials for or performing labor in the prosecution of the work provided for in ANNUAL CONTRACT FOR RESURFACING OF BITUMINOUS ROADWAYS AND REPAIRS TO SIDEWALKS and any authorized extensions or modification thereof, including all amounts due for materials, lubricants, oil, gasoline, repairs on machinery, equipment and tools consumed or used in connection with the construction of such work, and all insurance premiums on said work, and for all labor performed in such work, whether by subcontractors or otherwise, then this obligation shall be void; otherwise to remain in full force and effect,

PROVIDED, HOWEVER, that (except as to the OWNER) no suit, action or proceeding by reason of any default whatever shall be brought on this Bond after two years from the day on which the final payment under the Contract falls due,

AND PROVIDED, that any alterations that may be made in the terms of the Contract or in the work to be done under it, or any assignment, transfer or subletting of any part of the work, or the giving by the OWNER of any extension of time for the performance of the Contract, or any other forbearance on the part of either the OWNER or the CONTRACTOR to the other, shall not in any way release the CONTRACTOR and the Surety or Sureties, or either or any of them, their heirs,

executors, administrators, successors or assigns from their liability hereunder, notice to the Surety or Sureties of any such altercations, assignment, transfer, subletting, extension or forbearance being hereby waived.

This Bond is made for the use and benefit of all persons, firms, and corporations who may furnish materials, or perform any labor for or on account of said work, construction or improvements, or who may have any suits or claims for injury or damage to persons or property resulting from or arising out of the work done under this Contract, and they and each of them are hereby made obligees hereunder the same as if their own proper names were written herein as such, and they and each of them may sue hereon in their own names for their own use and benefit.

And the Surety, for value received, hereby stipulates and agrees that no change, extension of time, alteration or addition to the terms of the Contract or to the work to be performed hereunder, or the Specifications accompanying the same, shall in any way affect its obligations on this Bond, and it does hereby waive notice of any such changes, extension or time, alteration or addition to the terms of the Contract or to the work, or to the Specifications.

IN WITNESS WHEREOF, said CONTRACTOR and Surety have hereunto set their respective names

this _____ day of _____, 20_____.

WITNESSES:

CONTRACTOR (SEAL)

NAME _____ BY _____
SIGNATURE AND TITLE

ADDRESS _____ BY _____
SURETY (SEAL)

NAME _____ BY _____
SIGNATURE AND TITLE

ADDRESS _____ BY _____
ATTORNEY-IN-FACT

POWER OF ATTORNEY: Attorneys-in-fact who sign contract bonds must file with each bond a certified copy of their power of attorney to sign said bonds.

CITY OF WALTHAM, MASSACHUSETTS
CONSOLIDATED PUBLIC WORKS DEPARTMENT

5B - PERFORMANCE BOND
FOR
ANNUAL CONTRACT FOR
RESURFACING OF BITUMINOUS ROADWAYS AND REPAIRS TO SIDEWALKS
IN
WALTHAM, MASSACHUSETTS

KNOW ALL MEN BY THESE PRESENT, THAT _____

_____ AS PRINCIPAL AND

_____ AS SURETY

are held and firmly bound unto the CITY OF WALTHAM and to such persons, firms, and corporations, who furnish materials for or perform labor on the work, construction or improvements contemplated in the Contract hereinafter mentioned, or who may have any suits or claims for injury or damage to persons or property resulting from or arising out of the work done under this Contract

IN THE SUM OF _____ DOLLARS (\$ _____)

(lawful money of the United States of America) for the payment whereof the CONTRACTOR and the Surety or Sureties bind themselves and their heirs, executors, administrators, successors and assigns, jointly and severally, firmly by these presents.

THE CONDITION OF THIS OBLIGATION IS SUCH, that if the above bounden

heirs, executors, administrators and assigns, shall faithfully perform the Contract for ANNUAL CONTRACT FOR RESURFACING OF BITUMINOUS ROADWAYS AND REPAIRS TO SIDEWALKS on his part and during the life of any guaranty or warranty, including warranty for defective materials and workmanship required under this Contract, and satisfy all claims and demands incurred for the same; and shall fully indemnify and save harmless the OWNER from all costs and damage that it may suffer by reason of failure so to do, and shall fully reimburse and repay the OWNER all outlay and expense that the OWNER may incur in making good any such default, and shall promptly make payment to all persons supplying labor or materials for use in the prosecution of the work provided for in said Contract; and shall indemnify and save harmless the said OWNER, its officers and agents from any and all suits or claims for injury or damage to persons or property resulting from or arising out of the work done under this Contract, then this obligation shall be null and void; otherwise it shall remain in full force and effect,

PROVIDED, HOWEVER, that (except as to the OWNER) no suit, action or proceeding by reason of any default whatever shall be brought on this Bond after two years from the day on which the final payment under the Contract falls due,

AND PROVIDED, that any alterations that may be made in the terms of the Contract or in the work to be done under it, or any assignment, transfer or subletting of any part of the work, or the giving by the OWNER of any extension of time for the performance of the Contract, or any other forbearance on the part of either the OWNER or the CONTRACTOR to the other, shall not in any way release the CONTRACTOR and the Surety or Sureties, or either or any of them, their heirs,

executors, administrators, successors or assigns from their liability hereunder, notice to the Surety or Sureties of any such alterations, assignment, transfer, subletting, extension or forbearance being hereby waived.

This bond is made for the use and benefit of all persons, firms and corporations who may furnish materials, or perform any labor for or on account of said work, construction or improvements, or who may have any suits or claims for injury or damage to persons or property resulting from or arising out of the work done under this Contract, and they and each of them are hereby made obligees hereunder the same as if their own proper names were written herein as such, and they and each of them may sue hereon in their own names for their own use and benefit.

And the Surety, for value received, hereby stipulates and agrees that no change, extension of time, alteration or addition to the terms of the Contract or to the work to be performed hereunder, or the Specifications accompanying the same, shall in any way affect its obligations on this Bond, and it does hereby waive notice of any such changes, extension of time, alteration or addition to the terms of the Contract or to the work, or to the Specifications.

IN WITNESS WHEREOF, said CONTRACTOR and Surety have hereunto set their respective names

this _____ day of _____, 20_____.

WITNESSES:

CONTRACTOR (SEAL)

NAME _____ BY _____
SIGNATURE AND TITLE

ADDRESS _____ BY _____
SURETY (SEAL)

NAME _____ BY _____
SIGNATURE AND TITLE

ADDRESS _____ BY _____
ATTORNEY-IN-FACT

POWER OF ATTORNEY: Attorneys-in-fact who sign contract bonds must file with each bond a certified copy of their power of attorney to sign said bonds.

Compliance, Section. 5C

These documents must be signed and returned with your bid

Compliance

The compliance documents in this section must be completed, signed and returned **with your bid package.**

Purchasing Department

City of Waltham
610 Main Street
Waltham, MA 02452

Failure to submit the completed documents will cause the disqualification of the proposal.

Section Index

	Check when Complete
• Non-collusion form and Tax Compliance form.....	_____
• Corporation Identification Form.....	_____
• Certificate of Vote Authorization.....	_____
• Certificate of Insurance (showing all limits of WC &GL).....	_____
• Three (3) References.....	_____
• 5% Bid Bond or Certified Check>.....	_____
• Debarment Certificate	_____
• Prevailing Wage Certificate.....	_____
• Right-to-know Law.....	_____
• OSHA 10 Certificate for all Assigned Employees (MGL ch30, §39M and Ch 149)	_____
• Mass DOT Prequalification evidence.....	_____

Before the commencement of the Job, the contractor must provide to the above office:

- Performance Bond for 100% of the contract value and naming the City of Waltham ***(Letter must be included with your response)***

Your Company's Name: _____

Service or Product Bid _____

NOTE: Failure to submit any of the required documents, in this or in other sections, with your bid response package may cause the disqualification of your proposal.

NON-COLLUSION FORM AND TAX COMPLIANCE FORM

CERTIFICATE OF NON-COLLUSION

The undersigned certifies under penalties of perjury that this bid or proposal has been made and submitted in good faith and without collusion or fraud with any other person. As used in this certification, the word "person" shall mean any natural person, business, partnership, corporation, union, committee, club, or other organization, entity or group of individuals. The undersigned certifies that no representations made by any City officials, employees, entity, or group of individuals other than the Purchasing Agent of the City of Waltham was relied upon in the making of this bid

(Signature of person signing bid or proposal) Date

(Name of business)

TAX COMPLIANCE CERTIFICATION

Pursuant to M.G.L. c. 62C, & 49A, I certify under the penalties of perjury that, to the best of my knowledge and belief, I am in compliance with all laws of the Commonwealth relating to taxes, reporting of employees and contractors, and withholding and remitting child support.

Signature of person submitting bid or proposal Date

Name of business

NOTE

Failure to submit any of the required documents, in this or in other sections, with your bid response package may cause the disqualification of your proposal.

CERTIFICATE OF VOTE OF AUTHORIZATION

Date:

I _____, Clerk of _____ hereby certify that at a meeting of the Board of Directors of said Corporation duly held on the _____ day of _____ at which time a quorum was present and voting throughout, the following vote was duly passed and is now in full force and effect:

VOTED: That _____ (*name*) is hereby authorized, directed and empowered for the name and on behalf of this Corporation to sign, seal with the corporate seal, execute, acknowledge and deliver all contracts and other obligations of this Corporation; the execution of any such contract to be valid and binding upon this Corporation for all purposes, and that this vote shall remain in full force and effect unless and until the same has been altered, amended or revoked by a subsequent vote of such directors and a certificate of such later vote attested by the Clerk of this Corporation.

I further certify that _____ is duly elected/appointed _____ of said corporation

SIGNED:

(Corporate Seal)

Clerk of the Corporation:

Print Name: _____

COMMONWEALTH OF MASSACHUSETTS

County of _____

Date:

Then personally appeared the above named and acknowledged the foregoing instrument to be their free act and deed before me, _____

Notary Public;

My Commission expires: _____

CORPORATION IDENTIFICATION

The bidder for the information of the Awarding Authority furnishes the following information.

If a Corporation:

Incorporated in what state _____
President _____
Treasurer _____
Secretary _____
Federal ID Number _____

If a foreign (out of State) Corporation – Are you registered to do business in Massachusetts?

Yes _____, No _____

If you are selected for this work you are required under M.G.L.ch. 30S, 39L to obtain from the Secretary of State, Foreign Corp. Section, State House, Boston, a certificate stating that you Corporation is registered, and furnish said certificate to the Awarding Authority prior to the award.

If a Partnership: (Name all partners)

Name of partner _____
Residence _____
Name of partner _____
Residence _____

If an Individual:

Name _____
Residence _____

If an Individual doing business under a firm's name:

Name of Firm _____
Name of Individual _____
Business Address _____
Residence _____
Date _____

Name of Bidder _____
By _____
Signature _____
Title _____

Business Address _____ (POST OFFICE BOX NUMBER NOT ACCEPTABLE)

State _____ Telephone Number _____ Today's Date _____

PROVIDE THREE (3) SERVICE APPROPRIATE REFERENCES

1. Company Name:

Address:

Contact Name:

Phone #

Type of service/product provided to this Company:

Dollar value of service provided to this Company:

2. Company Name:

Address:

Contact Name:

Phone #

Type of service/product provided to this Company:

Dollar value of service provided to this Company:

3. Company Name:

Address:

Contact Name:

Phone #

Type of service/product provided to this Company:

Dollar value of service provided to this Company:

NOTE

Failure to submit any of the required documents, in this or in other sections, with your bid response package will be cause for the disqualification of your company.

**WEEKLY PAYROLL RECORDS REPORT &
STATEMENT OF COMPLIANCE**

In accordance with Massachusetts General Law c. 149, §27B, a true and accurate record must be kept of all persons employed on the public works project for which the enclosed rates have been provided, A Payroll Form has been printed on the reverse of this page and includes all the information required to be kept by law. Every contractor or subcontractor is required to keep these records and preserve them for a period of three years from the date of completion of the contract.

In addition, every contractor and subcontractor is required to submit, on a weekly basis, a copy of his or her weekly payroll records to the awarding authority. For every week in which an apprentice is employed, a photocopy of the apprentice's identification card must be attached to the payroll report. Once collected, the awarding authority is also required to preserve those reports for three years.

In addition, each such contractor, subcontractor, or public body shall furnish to the awarding authority directly, within fifteen days after completion of its portion of the work, a statement, executed by the contractor, subcontractor or public body who supervises the payment of wages, in the following form:

STATEMENT OF COMPLIANCE

_____, 200_____

I _____, _____
(Name of signatory party) (Title)

I do hereby state that I pay or supervise the payment of the persons employed by

_____ on the _____
(Contractor, subcontractor or public body) (Building or project)

and that all mechanics and apprentices, teamsters, chauffeurs and laborers employed on said project have been paid in accordance with wages determined under the provisions of sections twenty-six and twenty-seven of chapter one hundred and forty nine of the General Laws.

Signature _____, Title _____

Print _____

WEEKLY PAYROLL REPORT FORM

Company Name: _____
 Prime Contractor

Project Name: _____
 Subcontractor
 List Prime Contractor: _____

Awarding Auth.: _____
 Employer Signature: _____

Work Week Ending: _____
 Print Name & Title: _____

Final Report

Employee Name & Address	Work Classification	(A) Hours Worked							(B) Hourly Base Wage	Employer Contributions			(F) [B+C+D+E] Hourly Total Wage (prev. wage)	(G) [A*F] Weekly Total Amount
		Tot. Hrs.								(C) Health & Welfare	(D) Pension	(E) Supp. Unemp.		
		S	M	T	W	T	F	S						

NOTE: Every contractor and subcontractor is required to submit a copy of their weekly payroll records to the awarding authority.

RIGHT TO KNOW LAW

Any vendor who receives an order or orders resulting from this invitation agrees to submit a Material Safety Data Sheet (MSDS) for each toxic or hazardous substance or mixture containing such substance, pursuant to M.G.L. c. 111F, §§8,9 and 10 and the regulations contained in 441 CMR 21.06 when deliveries are made. The vendor agrees to deliver all containers properly labeled pursuant to M.G.L. c. 111F §7 and regulations contained in 441 CMR 21.05. Failure to furnish MSDS and/or labels on each container may result in civil or criminal penalties, including bid debarment and action to prevent the vendor from selling said substances, or mixtures containing said substances within the Commonwealth. All vendors furnishing substances or mixtures subject to Chapter 111F or M.G.L. are cautioned to obtain and read the laws, rules and regulations referenced above. Copies may be obtained from the State House Bookstore, Secretary of State, State House, Room 117, Boston, MA (617) 727-2834.

Authorized Signature Indicating Compliance with the Right-to-know laws:

Signature

Date

Print Name

NOTE

Failure to submit any of the required documents, in this or in other sections, with your bid response package may cause the disqualification of your proposal.

DEBARMENT CERTIFICATION

In connection with this bid and all procurement transactions, by signature thereon, the respondent certifies that neither the company nor its principals are suspended, debarred, proposed for debarment, declared ineligible, or voluntarily excluded from the award of contracts, procurement or non procurement programs from the Commonwealth of Massachusetts, the US Federal Government and /or the City of Waltham. "Principals" means officers, directors, owners, partners and persons having primary interest, management or supervisory responsibilities with the business entity. Vendors shall provide immediate written notification to the Purchasing Agent of the City of Waltham at any time during the period of the contract or prior to the contract award if the vendor learns of any changed condition with regards to the debarment of the company or its officers. This certification is a material representation of fact upon which reliance will be placed when making the business award. If at any time it is determined that the vendor knowingly misrepresented this certification, in addition to other legal remedies available to the city of Waltham, the contract will be cancelled and the award revoked.

Company Name _____

Address _____

City _____, **State** _____, **Zip Code** _____

Phone Number (____) _____

E-Mail Address _____

Signed by Authorized Company Representative:

Print name _____,

Date _____

10 HOURS OSHA TRAINING CONFIRMATION

Chapter 306 of the Acts of 2004

CONSTRUCTION PROJECTS

AN ACT RELATIVE TO THE HEALTH AND SAFETY ON PUBLIC

The undersigned hereby certifies that all employees to be employed at a worksite for construction, reconstruction, alteration, remodeling, repair, installation, demolition, maintenance or repair of any public work or any public building estimated to cost more than \$10,000.00 have successfully completed a course in construction safety and health approved by the **United States Occupational Safety and Health Administration** that is at least **10 hours** in duration at the time the employee begins work and who shall furnish documentation of successful completion of said course with the first payroll report for each employee and will comply with all laws and regulations applicable to awards of subcontracts subject to section 44F.

Company Name: _____

Address: _____

Signature: _____

Title: _____

Print Name _____

Date _____

See Chapter 306 of the Acts of 2004

NOTE

Failure to submit any of the required documents, in this or in other sections, with your bid response package will be cause for the disqualification of your company.

**CITY OF WALTHAM, MASSACHUSETTS
CONSOLIDATED PUBLIC WORKS DEPARTMENT**

**6 - SPECIFICATIONS
FOR
ANNUAL CONTRACT FOR
RESURFACING OF BITUMINOUS ROADWAYS AND REPAIRS TO SIDEWALKS
IN
WALTHAM, MASSACHUSETTS**

1) GENERAL PROVISIONS

(a) The attention of the CONTRACTOR is called to the provisions of MGL Chapter 149, §6: that in the employment of mechanics, teamsters and laborers, preference shall first be given to citizens of the Commonwealth of Massachusetts who have served in the Armed Forces of the United States in time of war and have been honorably discharged therefrom, or released from active duty therein, and who are qualified to perform the work, to which the employment relates, and secondly, to citizens of the Commonwealth of Massachusetts generally and if they cannot be obtained in sufficient numbers, then to citizens of the United States: that no laborer, workman or mechanic working within the Commonwealth of Massachusetts in the employ of the CONTRACTOR, subcontractor or other person doing or contracting to do the whole or any part of the work contemplated by this agreement shall be requested to work more than eight hours in any one day, or shall be requested or required to work more than forty hours any one week, except in cases of extraordinary emergency, and that the CONTRACTOR will in all things, observe and comply with any and all other provisions of law relative to agreements or contracts for the performance of public work.

(b) The CONTRACTOR shall do all the work and furnish all the labor, materials, implements, tools, machinery and applications, except as herein otherwise specified, necessary or proper for performing and completing the work required by this contract in the manner herein specified.

(c) All the work, labor and materials to be done and furnished under this contract shall be done and furnished strictly pursuant to and in accordance with the directions of the OWNER as given from time to time during the progress of the work under the terms of this contract.

(d) The CONTRACTOR shall complete the entire work in accordance with the specifications for the work and to the satisfaction of the OWNER.

(e) The INVITATION TO BID and the BID submitted by the CONTRACTOR shall be made parts of this contract.

(f) The CONTRACTOR, during the progress of the work, shall take every precaution to ensure the absolute safety of the public from injury.

(g) The CONTRACTOR agrees to give his personal attention to the work or, during his absence, agrees to delegate his authority to a duly authorized agent who shall represent him in the decision of all matters relative to the construction of the work. The CONTRACTOR is to be responsible for any damage to property resulting from his operation.

(h) The attention of the CONTRACTOR is also called to the provisions relative to directing or requiring employees to lodge, board or trade at any particular place or with any particular person or persons and the CONTRACTOR agrees to be governed by such provisions.

(i) The CONTRACTOR shall keep himself fully informed as to all laws, bylaws, ordinances, regulations, orders, decrees and wage rates, and shall protect and indemnify the CITY and all its officers, agents and servants against any claim or liability arising from, or based on, the violation of any such all laws, bylaws, ordinances, regulations, orders, decrees and wage rates, whether by himself or his employees or subcontractors.

(j) The CONTRACTOR agrees to take out and maintain at his own expense insurance against damage arising from injury to his employees, in accordance with MGL Chapter 152 and amendments thereof.

2) DEFINITIONS

(a) "ENGINEER," "CITY ENGINEER," "CPW ASSISTANT DIRECTOR," "CITY" or "OWNER" shall mean the CITY OF WALTHAM, acting directly or through properly authorized agents; such agents acting within the scope of the particular duties entrusted to them.

(b) The word "CONTRACTOR" shall mean the party or parties contracting to perform the work covered by this contract or his or their legal representative successors or assigns.

3) EXAMINATION OF THE SITE

Before submitting his BID, the CONTRACTOR shall visit the site, examine its condition and thoroughly acquaint himself with the obstacles and advantages of performing the work. He shall also study the plans and specifications explanatory of the work and compare the same with the information gathered by the examination of the site.

4) SITE CONDITIONS

It is expressly understood and agreed that the CITY does not warrant or guarantee that the materials encountered during construction will be the same as the information given on the drawings. The results and descriptions are for the information of the CONTRACTOR, but are not guaranteed. The CONTRACTOR must satisfy himself regarding the character and quantities of the various materials and work to be done. It is further understood and agreed that the Bidder or CONTRACTOR will not use any of the information obtained in such examination in any manner as a basis or ground of claim or demand of any nature against the CITY arising from or by reason of any variance that may exist between the samples examined and described and the actual materials or structures encountered during the construction work.

5) ESTIMATED QUANTITIES

Wherever the estimated quantities of work to be done and materials to be furnished under this Contract are shown in any of the documents, including the BID, they are given for use in comparing Bids. The right is especially reserved to increase or diminish them as may be deemed reasonably necessary or desirable by the OWNER to complete the work contemplated by this CONTRACT, and such increase or reduction shall in no way invalidate this CONTRACT, nor shall any such increase or diminution give cause for claims or liability for damage. CONTRACTOR shall order materials based on actual field measurements and not quantities estimated in the Bid. The City of Waltham will not be responsible for overstocked materials.

6) ITEMS NOT LISTED IN THE BID

The lump sum and unit price items listed in the Bid form are intended to cover all items of work to be done and materials and work to be furnished to fully complete the work in accordance with the Contract Documents. Appurtenant items of work as shown on the Drawings or as specified or as required, and parts of the work, materials, and equipment not listed separately and not shown or specified to complete the work under the item or not shown in the Bid shall be considered as incidental to the applicable item and included in the cost of payment under the various applicable Bid items of work, and no separate payment will be made for such items. It shall be the responsibility of the CONTRACTOR to verify any missing or incomplete data.

7) BALANCED BIDDING

Bids should be made on each separate item of work shown in the BID with reasonable relation to the probable cost of doing the work included in such items, and the right is reserved to reject wholly any Bid where an item or items thereof are obviously unbalanced or appear to the CITY to be so unbalanced as to affect or to be liable to affect adversely any interests of the CITY. **The attention of the Bidder is called to the fact that unbalancing of Bids may adversely affect the CONTRACTOR if certain portions of the work are increased or decreased as provided in the paragraph 5).**

8) DISCREPANCIES, ERRORS AND OMISSIONS

Drawings and specifications are intended to be explanatory of each other, but should any discrepancy appear or any misunderstanding arise as to the import of anything contained in either, the interpretation and decision of the OWNER shall be final and binding on both parties to this contract. Any correction of error or omissions in drawings and specifications may be made by the OWNER when such correction is necessary for the proper fulfillment of their intention as construed by him. Where said correction of errors or omissions, except as provided in the next two paragraphs below, adds to the amount of work to be done by the CONTRACTOR, compensation for said additional work shall be made under the provision for "Claims for Additional Work," except where the additional work may be classed under some item of work for that a unit price is included in the BID.

The fact that specific mention of a fixture, or any part of the work, is omitted in the specifications, whether intentionally or otherwise, when the same is clearly shown or indicated on the drawings, or is usually and customarily required to complete such work as is specified herein, will not entitle the CONTRACTOR to consideration in the matter of any claim for extra compensation. The said fixtures or work, or both, must be installed or done the same as if called for by both the drawings and the specifications.

Work indicated on the drawings and not mentioned in the specifications or vice versa, and all work and material usual and necessary to make the work complete in all its parts, whether or not indicated on the drawings or mentioned in the specifications shall be furnished and executed the same as if called for by both the drawings and specifications.

9) CLAIMS FOR ADDITIONAL WORK

The CONTRACTOR shall make no claim for additional work or materials unless the same shall be performed or furnished in pursuance of an order from the OWNER and unless the same shall be specifically authorized in writing, signed by the MAYOR. Notice of all claims for additional work and material shall be made to the OWNER in writing ten days from the beginning of such work or the furnishing of such materials.

10) SUBCONTRACTS

No work may be sublet or subcontracted without prior written approval of the OWNER.

11) OWNER TO BE REFEREE

To minimize disputes and litigation, it is further agreed by and between the parties to this contract that the OWNER shall decide all questions arising during the progress of the work and his decisions shall be final and binding upon the parties to this contract.

12) JURISDICTIONAL DISPUTES

It shall be the responsibility of the CONTRACTOR to see that the proper trades perform their respective work.

13) COMPLETION OF THE WORK

(a) The CONTRACTOR agrees to complete the work hereunder required in every particular in a prompt and diligent manner and to the satisfaction of the OWNER in accordance with the plans, specifications and this contract within the period of the time stated in the BID.

(b) The MAYOR shall have the right to extend the time for completion of said work but such time shall not be extended except upon application in writing by the CONTRACTOR and good cause shown.

(c) The time shall be extended if delay is caused by a strike or boycott for which the CONTRACTOR is in no way responsible and which the CONTRACTOR cannot reasonably avoid.

(d) Neither an extension of time, for any reason beyond that fixed herein for the completion of the work nor the doing and acceptance of any part of the work called for by this contract, shall be deemed to be a waiver by the CITY OF WALTHAM of the right to abrogate this contract for abandonment or delay in the manner provided for in paragraph 14) of this contract.

14) ABANDONMENT OF THE WORK

The CONTRACTOR further agrees that if the work to be done under this contract shall be abandoned, or if the work shall not be fully completed on the day herein specified, or if this contract shall be assigned by the CONTRACTOR otherwise than as herein specified, or if at any time the OWNER shall be of the opinion and shall certify in writing to the MAYOR, that the work is unnecessarily or unreasonably delayed, or that the CONTRACTOR is willfully violating any of the conditions or agreements of this contract, or is not executing said contract in good faith, or is not making such progress in the execution of the contract as to indicate its completion within the required time, the MAYOR shall have the power and the right to notify the CONTRACTOR to discontinue said work or such part thereof as the MAYOR may designate, and the MAYOR shall thereupon have the power and the right to notify the CONTRACTOR to discontinue said work or such part thereof as the MAYOR may designate; and the MAYOR shall thereupon have the power by contract or otherwise as he may determine, to employ such persons and obtain such appliances and tools as he may deem necessary to work at, and be used to complete the work herein described or such part thereof as he may deem necessary and to use such implements and materials of every description as may be found upon the premises both such as enter into the completed work and such as are necessarily used in and about the same in the course of construction, and to procure other materials and implements to the CONTRACTOR; and the expense so charged shall be deducted and paid by the MAYOR out of such money as may be deemed either due at any time thereafter become due to the CONTRACTOR under this contract or any part thereof, and in case such expense is less than the sum that would have been payable under this contract if the same had been completed by the CONTRACTOR, then the CONTRACTOR shall be entitled to receive the difference and in case such expense exceeded

the sum which would have been payable under this contract if the same had been completed by the CONTRACTOR, then the CONTRACTOR shall pay the amount of such excess to the CITY OF WALTHAM.

15) PAYMENT TO THE CONTRACTOR

The OWNER shall, from time to time, certify as to the work done to date and the value thereof, and payment shall be made to the CONTRACTOR on a unit price basis for the work completed to date. The CITY OF WALTHAM shall retain five percent of such value and pay to the CONTRACTOR the balance, after deduction therefrom all previous payments and all sums to be kept or retained under the provisions of previous payments and all sums to be kept or retained under the provisions of this contract. It is further agreed that the sum as herein provided will be paid by the CITY OF WALTHAM and shall be received by the CONTRACTOR as full compensation for furnishing and installing material and executing all the work contemplated by the CONTRACTOR, also for all loss or damage arising out of the nature of the work aforesaid or from the action of the elements or from any unforeseen obstruction or difficulties that may be encountered in the prosecution of the same or from hindrance or delay from any cause whatsoever in the progress of the work and for all risks of every description connected with the work; also for all expenses incurred by or in consequence of the suspension or discontinuance of said work as herein specified and for well and faithfully completing the whole in the manner and in accordance with the plans and specifications and requirements of the OWNER. Ninety five percent of such sum shall be paid by the CITY OF WALTHAM to the CONTRACTOR, it being understood that the final payment be made within sixty days after this contract is completely finished provided that the OWNER shall certify in writing that all the work has been done to his satisfaction, and provided further that nothing herein contained shall be construed to effect the right of the MAYOR hereby reserved, to reject the whole or any portion of the aforesaid work should the certificate be found or known to be inconsistent with the terms of this agreement, or otherwise improperly given and provided further that if at any time there shall be any claim of the sort mentioned in paragraph 16) or paragraph 32) of this contract to the MAYOR, the CITY OF WALTHAM shall have the right to retain out of the payment an amount sufficient to pay such claim until the same shall be satisfied or canceled.

16) UNPAID CLAIMS

The CONTRACTOR further agrees that he will pay all bills for labor and materials contracted for by him on account of the work herein contemplated and that he will furnish the MAYOR at her request with evidence satisfactory to him that all persons who have done work or furnished material under this contract and all claims of private corporations or individuals for damages of any kind, caused by the construction of said work, have been fully paid or satisfactorily secured. The MAYOR shall cause to be retained, out of such amount due the CONTRACTOR, sums sufficient to cover any such unpaid claims.

17) PERMITS

The CONTRACTOR shall obtain all necessary permits for the execution of this contract, including a street opening permit, obtained at no charge from the Consolidated Public Works Department (781) 314-3800.

18) PROSECUTION AND PROGRESS

The CONTRACTOR shall commence work within fifteen days after the mailing of the executed CONTRACT unless otherwise ordered in writing by the OWNER, and the CONTRACTOR shall thereafter prosecute the work at such places and in such order as the OWNER may from time to time prescribe.

Should the prosecution of the work for any reason be discontinued, the CONTRACTOR shall notify the OWNER at least twenty-four hours prior to resumption of operations.

19) SCHEDULE

Within fifteen days after the mailing of the executed CONTRACT, a meeting shall be held between the OWNER and the CONTRACTOR who is awarded the Bid. At this meeting, a schedule of the work to be done shall be set up by the OWNER and the CONTRACTOR. Time schedules for various phases of construction will be determined and compiled in a manner that is satisfactory to both the CONTRACTOR and the OWNER.

20) LINES AND GRADES

The OWNER will establish sufficient points to fix the location, alignment and elevation of the work. The CONTRACTOR will furnish the layout of all parts of the work from the points furnished and shall maintain all such points, lines and grades at no additional cost to the CITY. Finished surfaces, in all cases, shall conform as near as practical to the lines and grades given. The CONTRACTOR shall supply appropriate survey equipment for use by the OWNER to permit the OWNER to check lines and grades.

21) PROPERTY BOUNDS

The CONTRACTOR shall exercise due care when working around all street and property bounds (whether granite, concrete, iron pins, wooden stakes, spikes or nails) that are to remain. Should any damage to a bound result from the actions of the CONTRACTOR, the bound shall be replaced and/or realigned by the CONTRACTOR with the assistance of a Professional Land Surveyor, as required by the OWNER, at no cost to the CITY. In the event of changes in grade and the bound is not to be replaced, the CITY will provide a frame and cover to be installed by the CONTRACTOR as incidental to the work with no additional cost to the CITY.

22) NOTICE TO UTILITY COMPANIES

The CONTRACTOR shall comply with MGL Chapter 82, §40. Written notice shall be given by the CONTRACTOR to all public service corporations or municipal and State officials owning or having charge of publicly or privately owned utilities at least one week in advance of commencement of operations that will affect such utilities. These shall include, but not be limited to gas, electricity, water and sewer, fire alarm, cable television or telephone services within the limits of the contract. The CONTRACTOR shall, at the same time, file a copy of such notice with the OWNER.

23) SIGNS

When signs are removed for purposes of construction they shall be replaced in a timely manner as required by the OWNER. Stop signs, Do Not Enter signs, one-way signs and any other signs that would leave hazardous conditions if removed shall be maintained unless appropriate safety precautions have been taken as approved by the OWNER.

24) PROTECTION OF UTILITY SERVICES AND MAINS

The CONTRACTOR shall make his own investigation and take due caution to assure that no damage to existing structures, mains, drainage lines, conduit, or other utilities will occur as a result of his operations. The CONTRACTOR shall notify Mass. DIG SAFE (888) 344-7233 and procure a DIG SAFE number at each location prior to disturbing ground in any way.

25) UTILITY COORDINATION

The CONTRACTOR shall be responsible for coordinating all efforts of the respective utility companies for any relocation or work efforts. Utilities include:

NSTAR	800 Boylston Street	Boston, MA 02199-8003	John Zappi	(339) 987-7768
National Grid	160 Newton Street	Waltham, MA 02452	Kevin Souza	(781) 398-7301
Verizon	480 Rear Arsenal Street	Watertown, MA 02472	Ed McCarthy	(617) 673-9060
Comcast	55 Concord Street	North Reading, MA 01864	Bob Hagwood	(508) 208-0646
RCN	201 University Ave	Westwood, MA 02090	Maintenance	(877) 726-7000
Street Dept.	167 Lexington Street	Waltham, MA 02452	Arthur Mullin	(781) 314-3859
Water & Sewer	169 Lexington Street	Waltham, MA 02452	John Meconiates	(781) 314-3827

26) ACCESS TO AREA MERCHANTS, BUSINESSES, HOUSES AND GARAGES

The CONTRACTOR shall adjust and provide a suitable vehicle and pedestrian access to all area merchants, businesses, houses and garages at all times as necessary and to the satisfaction of the ENGINEER.

27) MATERIALS

Slips for materials purchased to be used on the work shall be submitted to the OWNER prior to installation of the materials. All slips shall clearly show the type and/or class of the material and the quantity purchased. The Vendor's name shall be shown on all slips.

28) MATERIALS REMOVED AND STACKED

Unless otherwise specified, all materials to be removed and stacked shall remain the property of the City of Waltham. The CONTRACTOR shall carefully remove, transport and stack any of these materials at an area within the City of Waltham, designated by the OWNER. If the City does not want any of these materials, they shall become the property of the CONTRACTOR and shall be removed from the project site and properly disposed of at no additional cost to the CITY.

29) INVOICING

The contractor shall submit a separate invoice for each street and it shall include the total cost of improving said street/sidewalk including all equipment, labor, materials, police details, other safeguards as required and all else incidental thereto.

30) DISPOSAL OF SURPLUS MATERIAL

All existing and other materials not required or needed for use on the project, and not required to be removed and stacked, shall become the property of the CONTRACTOR and shall be immediately removed from the site during the construction period and legally disposed of.

31) PROTECTION OF CATCH BASINS AND WATER RESOURCES

The CONTRACTOR shall take great care to prevent excavated material and pavement from entering catch basins and manholes. In the event such material enters these structures, it shall be immediately removed. Silt fabric shall be installed between the grate and cover of catch basins and removed as soon as protection is no longer required.

32) DAMAGES

(a) On any and all areas where work of any description whatsoever is performed, the CONTRACTOR shall be held strictly responsible for all damage in the execution of this contract and the restoration to the original condition of all driveways, walks, lawns, gardens, shrubbery, buildings, stone bounds, walls, ornamentals, utilities, etc., located within the locus of this contract and all to the satisfaction of the OWNER.

(b) The CONTRACTOR further agrees that he will be responsible for any damage to any person or property resulting from defects or from any cause whatsoever during the progress of the work or at any time before its completion and final acceptance, and that he will indemnify and save harmless the CITY OF WALTHAM from all suits or actions of every name and description brought for or on account of injuries or damages received by any person or persons from the CONTRACTOR, his servants or agents, in the construction of said work or in consequence of any negligence regarding the same, or improper materials used in its construction, or by or on account or any act or omission of the CONTRACTOR or his agents.

(c) The CONTRACTOR further agrees that so much of the money due to him under this contract or agreements, as shall be considered necessary by the MAYOR, may be retained by the CITY OF WALTHAM until such suits or claims for damages as aforesaid, shall have been settled and evidence to that effect furnished to the satisfaction of the MAYOR.

33) REPAIRS AND REPLACEMENTS

(a) If at any time during the period of one year from the date of final completion of the work contemplated in this contract, as determined by the OWNER, any part of such shall, in the opinion of the OWNER require replacing or repairing, or damage to other property of the CITY is caused owing to any defect in the work, the OWNER may notify the CONTRACTOR in person or by mail to make the required repairs or replacements and repair such damage.

(b) If the CONTRACTOR shall neglect to make such repairs or replacements to the satisfaction of the OWNER within ten days from the date of giving or mailing such notice, then the OWNER may employ other persons to make the same.

(c) The CONTRACTOR agrees, upon demand, to pay the CITY all amounts that it expends for such repairs or replacements.

34) PUBLIC SAFETY AND CONVENIENCE

The CONTRACTOR shall provide necessary access for fire apparatus and other emergency vehicles through work zones to abutting properties at all times.

At the end of each working day, trenches shall be backfilled to grade, or covered with secured steel plates. Each edge of the plates shall either be beveled and lay flat, or protected by a bituminous ramp at a slope of two feet horizontally and one inch vertically. Any temporary patching material may be used to construct the ramps. The cost of patching materials, maintenance and removal will be considered incidental to items in the contract and there will be no separate payment.

Sweeping and cleaning shall be performed at the end of each day, and throughout the day when conditions warrant. Sweeping and cleaning shall be considered incidental to the work being performed. When requested by the OWNER, calcium chloride shall be applied to unpaved surfaces as specified under ITEM 440.000 of the Technical Provisions.

Sweeping and cleaning of surfaces beyond the limits of the project required to clean up material caused by spillage or vehicle tracking during the various phases of the work shall be considered as incidental to the work being performed under the Contract and there will be no additional compensation.

35) SAFETY SIGNAGE

Unless otherwise indicated, the CONTRACTOR shall provide safety signage, lighted drums and barricades for detours, road closings, parking restrictions, etc. at his expense. Sign materials, legends and mounts shall be approved by the OWNER prior to installation.

36) MULTIPLE AWARDS OF CONTRACT

The contractor is made aware that the City may award this contract to more than one company to meet the demand of a busy street paving schedule

37) TRAFFIC POLICE

When, in the opinion of the OWNER, policemen are necessary for the directing of traffic, their services shall be paid for by the CONTRACTOR and the CONTRACTOR shall be reimbursed as specified under ITEM 999.001 of the Technical Provisions. To arrange for traffic police, telephone (781) 314-3604.

Instructions to Bidders

1. READ ALL DOCUMENTS.

Bidders should familiarize themselves with all the documents contained herein; it is mandatory that all Bids be in compliance with all the provisions contained in said documents.

2. FORMS AND ATTACHMENTS.

Bids are to be completed on the forms provided ONLY and enclosed in a sealed envelope marked on the outside "BID (title)" and the name and address of bidder. Attachments submitted in addition to the Waltham Purchasing Department produced forms may not be considered.

3. PRINTED OR TYPED RESPONSE.

All information must be typewritten or printed in ink, including the price the bidder offers in the space as provided on the bid form.

4. CORRECTIONS.

Bids that are submitted containing cross outs, white outs or erasures, will be rejected. All corrections or modifications to the original bid are to be submitted in a separate envelope, properly marked on the outside, "CORRECTION/ MODIFICATION TO BID (title)" and submitted prior to the bid opening.

ALL DOCUMENTS SUBMITTED WITH YOUR RESPONSE WILL BE INCORPORATED INTO THE CONTRACT.

5. PRICE IS ALL INCLUSIVE.

Bid prices shall encompass everything necessary for furnishing all items, materials, supplies or services as specified, and in accordance with the specifications, including proper packing, cost of delivery, and in the case of services, completion of same, as per specifications.

6. PRICE DISCREPANCY.

In the event of a discrepancy between the Unit Price and the Extension, the Unit Price shall prevail.

7. EXCEPTIONS

No Exceptions will be acceptable to the City. The City's intent is to purchase precisely what is specified in the document. Only equal or better grade specifications shall be considered by the City.

8. BID DEPOSITS.

Bid deposits are to be made payable to the City of Waltham. In the event that the successful bidder fails to execute a Contract within (10) days of the receipt of said contract, such security shall be retained by the city as liquidated damages. Unsuccessful bidders' deposits will be returned immediately following the award to said successful bidder.

9. WITHDRAW.

A Bid may be withdrawn by written request prior to the schedule for the Bid Opening. No withdrawals are permitted after the bid opening date and time. Withdrawals after the bid opening date will cause the forfeit of the bid Deposit.

10. AWARD.

Bids will be awarded not later than (90) ninety days after the scheduled bid opening date, unless otherwise stated, in the specifications. Unless otherwise specified, bids will be evaluated on the basis of, completeness of your RFP response, responsiveness, responsibility, best price and experience.

11. AWARD CRITERIA.

Qualified and responsive proposals will be evaluated based on the following rating, which will apply to all Price, Technical, Mass DOT Prequalifications and Compliance requirements

12. DISCOUNTS.

Discounts for prompt payments, based on City Pay Day, will be considered when making awards.

13. TAX EXEMPT.

Purchases by the City of Waltham are exempt from any Federal, State or Massachusetts Municipal Sales and/or Excise Taxes.

14. SAMPLES.

The Waltham Purchasing Department may require the submission of samples either before or after the awarding of a contract. Samples are to be submitted, at no charge to the City, so as to ascertain the product's suitability. If specifically stated in the Bid that samples are required, said samples must be submitted with the Bid prior to the Official Bid Opening. Failure to submit said samples would be cause for rejection of Bid. All samples must be called for and picked up within (30) thirty days of award or said samples will be presumed abandoned and will be disposed of.

15. ACTIVE VENDOR LIST.

Vendors who wish to remain on the Active Bid List must either submit a Bid, No Bid, or a letter requesting same, no later than the Official Bid Opening. This is applicable to those vendors who have received the Invitation to Bid.

16. FUNDS APPROPRIATION.

The contract obligation on behalf of the City is subject to prior appropriation of monies from the governmental body and authorization by the Mayor.

17. THE AWARDING AUTHORITY RESERVES THE RIGHT TO REJECT ANY OR ALL BIDS, OR ANY PART OF ANY BID, WHICH IN THE OPINION OF THE AWARDING AUTHORITY, IS IN THE BEST INTERESTS OF THE CITY OF WALTHAM.

18. THE TAX ATTESTATION CLAUSE, CERTIFICATION OF NON-COLLUSION AND THE CORPORATION INFORMATION, are an integral part of the Invitation for Bid and must be completed and signed by the person submitting the Bid, or by the person/persons who are officially authorized to do so.

19. STANDARD OF QUALITY.

Where, in the specifications, one certain kind, type, catalog number, brand or manufacturer of material is named, it shall be regarded as the required standard of quality. Where two or more are named, these are presumed to be equal and the Bidder may select one or the other. If the Bidder proposes to offer a substitute as an equal, he shall so indicate on the Bid Form, the kind, type, catalog number, brand, or manufacturer of material that is offered as an equal, and describe where it differs from the specifications. Substituted items must be capable of performing all the functions and/or operational features described or indicated in the specifications. Failure to indicate the description of any substitute item on the Bid will be interpreted to mean that the Bidder will furnish the item or service as specified.

20. MODIFICATION.

No agreement, understanding, alteration or variation of the agreement, terms or provisions herein contained shall bind the parties, hereto unless made and executed in writing by the parties hereto.

21. ASSIGNMENT.

The final payment for work done under this Contract shall be made only after the Contractor has signed a statement under the penalty of perjury, certifying that he has completed the work described in the final estimate. Neither party hereto shall assign this Contract or sublet it in part or as a whole without the prior written consent of the other party hereto. The Contractor shall not assign any sum or sums due or becoming due to him hereunder without the prior written consent of the City.

22. STABILITY of AGREEMENT:

Section 1. The failure of the City or the Union to insist, in any one or more incidents, upon performance of any of the terms or conditions of this Agreement shall not be considered as a waiver or relinquishment of the rights of the City or of the Union to future performance of any such term or condition and the obligations of the Union or of the City to such future performance shall continue in full force and effect.

Section 2. The provisions of this Agreement supersede any conflicting or inconsistent rule, regulation, ordinance or order promulgated by the City.

Section 3. Should any part hereof or any provision herein contained be rendered or declared invalid by reason of any existing or subsequently enacted legislation or by any decree of a court of competent jurisdiction, such invalidation of such part or portion of this agreement shall not invalidate the remaining portions hereof and the remaining parts of provisions shall remain in full force and effect.

23. DELIVERIES (if applicable):

a) The Contractor shall pay all freight and delivery charges. The Waltham Purchasing Department does not pay for shipping and packaging expenses. Items must be delivered as stipulated in the specifications. All deliveries must be made to the inside of city buildings. Sidewalk deliveries will not be accepted. City personnel are not required to assist in the deliveries and contractors are cautioned to notify their shippers that adequate assistance must be provided at the point of delivery, when necessary.

b) All items of furniture must be delivered inside the building, set up, in place and ready for use. Deliveries are to be made between the hours of 8:30 a.m. and 3:00 p.m., Monday through Friday, except on holidays.

c) All damaged items, or items which do not comply with specifications will not be accepted and title therefore will not vest to the Waltham Purchasing Department until such items are accepted and signed for, in good order, by the receiving department.

d) The contractor must replace, without further cost to the Waltham Purchasing Department, such damaged or non-complying items before payment will be made.

24. LABELING (if applicable).

All packages cartons or other containers must be clearly marked with (a) building and room destination; (b) description of contents of item number from specifications; (c) quantity; (d) City of Waltham Purchase Order Number and (e) Vendor's name and order number.

25. GUARANTEES.

Unless otherwise stipulated in the specifications, furniture, equipment and similar durable items shall be guaranteed by the contractor for a period of not less than one year from the date of delivery and acceptance by the receiving department. In addition, the manufacturer's guarantee shall be furnished. Any items provided under this contract which are or become defective during the guarantee period shall be replaced the contractor free of charge with the specific understanding that all replacements shall carry the same guarantee as the original equipment. The contractor shall make such replacement immediately upon receiving notice from the Purchasing Agent.

26. SINGLE VENDOR.

The Waltham Purchasing Department desires to award a single contract based on the Grand Total Price. However, where applicable, the City reserves the right to make multiple awards on a unit price basis if, in the opinion of the Waltham Purchasing Department, it is in the best interest of the Waltham Purchasing Department.

27. BEST AND FINAL OFFER.

The Waltham Purchasing Department reserves the right to request best and final offers from one or more bidders. Best and final offer will be exercised should the CPO deem it is in the best interest of the Waltham Purchasing Department in order to obtain the best value.

28. CHANGE ORDERS.

Change orders are not effective until, if, as and when signed by the Mayor and no work is to commence until the change orders are fully executed.

29. BID OPENING INCLEMENT WEATHER

If, at the time of the originally scheduled bid opening, City Hall is closed to inclement weather or another unforeseeable event, the bid opening will be extended until 2:00 PM on the next normal business day. Bids will be accepted until that date and time.

30. TIE BREAK

In the event of a tie where both vendors were responsive and responsible the vendors with a tie agree to a coin toss to determine the winner. The Coin toss will be executed in the presence of both vendors and a witness from the Purchasing Office. The coin will be flipped by the Chief Procurement Officer in the presence of the two bidders. A written record of the process you used, including the results and the names of those participating. The low bidders shall sign an agreement stating that they will abide by the results of the tie breaker. As an alternative, you may allow for a "second round" between the tied vendors

GENERAL CONDITIONS

1) INFORMATION

All information shall come from the Office of the City Agent. The Contractor shall inquire at this office for any information needed. Wherever the words “or equal as approved” are used, it is to be understood that the opinion of the City Agent shall govern.

2) SUITS

The Contractor shall assume defense of and shall indemnify and hold the City and its agents harmless from all suits and claims against them arising from the use of any invention, patent right labor or employment, or from any act of omission or neglect of the Contractor, his agents, employees or any subcontractor in performing the work, under this contract.

3) LAWS AND REGULATIONS

The Contractor shall conform to all the applicable rules, regulations, laws and ordinances of the City of Waltham, the United States of America and all agencies having jurisdiction.

4) PROTECTION OF PROPERTY

The Contractor shall take all proper precautions to protect the City’s property from damage and unnecessary inconvenience. Any City property damaged by the Contractor in carrying out the provisions of this contract shall be restored to its original condition, by and at the expense of the Contractor.

5) PROTECTION OF PERSONS

The Contractor shall take all proper precautions to protect persons from injury, unnecessary inconvenience, and shall be responsible for his failure to do so. The Contractor agrees to hold the City harmless from any and all liabilities of every nature and description, which may be suffered through bodily injury, including death, to any person, by reason of negligence of the Contractor, his agents or employees, or any subcontractor.

6) CONTRACT DURATION.

This contract is for the period required to complete the project exclusive of guarantees and Bonds and Insurances.

7) INSURANCE

A. **WORKMAN’S COMPENSATION:** The Contractor shall provide by insurance for the payment of compensation and furnishing of other benefits under Chapter 152 of the General Laws of the Commonwealth of Massachusetts to all persons to be employed under this contract, the premiums for which shall be paid by the Contractor.

B. **COMPREHENSIVE GENERAL LIABILITY**

Bodily Injury:	\$1,000,000 Each Occurrence
	\$2,000,000 Aggregate
Property Damage:	\$1,000,000 Each Occurrence
	\$2,000,000 Aggregate

C. **AUTOMOBILE (VEHICLE) LIABILITY**

Bodily Injury	\$2,000,000 Each Occurrence
Property Damage	\$1,000,000 Aggregate

D. **UMBRELLA POLICY** \$2,000,000

Your bid response must include a Certificate of Insurance with the above limits as a minimum. In addition, the Certificate of Insurance must have the following text contained in the bottom left box of the Certificate:

“The City of Waltham is a named additional insured for all insurances under the contract, excluding Automobile and Workers Compensation coverage”. Failure by the contractor to provide a current and updated insurance policy, during the entire duration of the contract, may result in additional legal liability.

The Certificate of Insurance must be mailed directly to:

Office of the Purchasing Agent
Purchasing Department
City of Waltham
610 Main Street
Waltham, MA 02452
General liability

8) LABOR AND MATERIALS BOND

The Contractor agrees to execute and deliver to the City, a Labor and Materials or Payment Bond equal to 100% of the contract value. This contract shall not be in force until said bond has been delivered and accepted by the City. Bond to be issued by a company licensed by the Commonwealth of Massachusetts.

A LETTER FROM A SURETY COMPANY CERTIFYING THAT THE CONTRACTOR IS QUALIFIED AND CAPABLE OF OBTAINING THE ABOVE BONDS SHOULD BE INCLUDED WITH HIS/HERS BID.

9) PERSONNEL:

The Contractor shall employ a competent supervisor and all properly licensed personnel necessary to perform the services required in this contract. The City Agent shall have the right to require the Contractor to remove and/or replace any of the personnel for nonperformance or for unprofessional behavior. The City Agent may require the Contractor to submit a weekly performance record of the areas and of the work performed, on forms approved by the City Agent. The Contractor or his supervisor shall be available to inspect such work as required by the City Purchasing Agent.

10) PREVAILING WAGES

The Contractor is required to pay the prevailing wages as determined under the provisions of Chapter 149, Sections 26 and 27D of the Massachusetts General Laws, including the submission of weekly payrolls to the awarding authority .Prevailing wage schedules will be found at www.city.waltham.ma.us/open-bids

11) MATERIALS *(if applicable)*

The City or its Agent reserves the right to approve or reject any supplies, material or equipment used by the Contractor. The Contractor agrees to replace any supplies, material or equipment used by the Contractor. The Contractor agrees to replace any rejected supplies, materials or equipment, to the satisfaction of the City or its Agents.

12) TERMINATION OF CONTRACT

This contract may be terminated by the City upon deliverance to the Contractor of a five-day written notice of said termination.

13) CONTRACT OBLIGATIONS

Contract obligations on behalf of the City are subject to an annual appropriation to cover the contract obligation.

14) BIDDER EXPERIENCE EVALUATION

Each bidder shall submit with his bid, all the information relative to their experience and qualifications in performing the work required under this contract and shall have been in business for a minimum of five (5) years, in order for their bid to be considered.

15) NOT-TO-EXCEED AMOUNT

The bid amount proposed in your company's response is a "not-to- Exceed" amount unless the City makes changes, in writing, to the scope of work to be performed. The Change Order must be signed and approved by the CPO PRIOR to the commencement of the change order work. A change order will be priced at the unit price. Failure to comply with this procedure will result in the cancellation of the contract and the non-payment of services provided

16) FINANCIAL STATEMENTS.

The City may require, within five (5) days after the bid opening, a complete and detailed Financial Statement prepared by a Certified Public Account, to determine a bidder's financial stability.

17) BREACH OF CONTRACT/ NON PERFORMANCE

If the Contractor shall provide services in a manner, which is not to the satisfaction of the City, the City may request that the Contractor refurnish services at no additional cost to the City until approved by the City. If the Contractor shall fail to provide services, which are satisfactory to the City, the City in the alternative may make

any reasonable purchase or Contract to purchase services in substitution for those due from the Contractor. The City may deduct the cost of any substitute Contract for nonperformance of services together with incidental and consequential damages from the Contract price and shall withhold such damages from sums due or to become due to the Contractor. If the damages sustained by the City exceed sums due or to become due, the Contractor shall pay the difference to the City upon demand. The Contractor shall not be liable for any damages sustained by the City due to the Contractor's failure to furnish services under the terms of this Contract if such failure is in fact caused by the occurrence of a contingency the nonoccurrence of which was a basic assumption under which this Contract was made, including a state of war, embargoes, expropriation of labor strike or any unanticipated federal, state or municipal governmental regulation of order, provided that the Contractor has notified the City in writing of such cause within seven (7) days after its occurrence.

18) RIGHT TO AUDIT

The Waltham Purchasing Department has the right to review and audit documents related to this contract. This right extends to any subcontractor, supplier or other entity used by the prime contractor to fulfill the obligations under this contract.

19) CITY ORDINANCE. APPROVAL OF CONTRACTS BY MAYOR, SEC. 3-12 OF THE CITY ORDINANCES.

All contract made by any department, board or commission where the amount involved is two thousand dollars (\$2,000) or more shall be in writing, and no such contract shall be deemed to have been made or executed until the approval of the Mayor is affixed thereto. Any construction contract shall, and all other contracts may, where the contract exceed five thousand dollars (\$5,000) be required to be accompanied by a bond with sureties satisfactory to the Mayor.

20) ACTIVE REPARATION CLAIMS

Does your company or any of its Principals have an active reparation Claim with the City. A claim is any demand by a contract for the payment of disputed invoices, payment penalties, labor disputes, interest, etc.

YES _____, NO _____ (*circle or check applicable*). If YES Please explain the nature of the claim, date of the claim and City Department

(Add an additional page if necessary)

21) REVISED MBE/WBE GOALS FOR, (if applicable), CERTAIN STATE FUNDED BUILDING PROJECTS ONLY

Pursuant to M.G.L. c 7, §40N and M.G.L. c. 7, §61, the Supplier Diversity Office ("SDO") (formerly SOMWBA) and the Division of Capital Asset Management ("DCAM") have set revised participation goals for Minority Business Enterprise ("MBE") and Women Business Enterprise ("WBE") participation for affected state funded building projects and state assisted municipal building projects as defined in the above referenced laws and related Executive Orders, including Executive Orders 524 and 526.

Effective January 1, 2012, and until such time as the goals may be revised, the MBE and WBE participation goals for building construction and design awards and expenditures on new projects advertised on or after the effective date will be a combined MBE/WBE goal as follows:

14.4% combined MBE/WBE participation on construction contract awards; and,

17.9% combined MBE/WBE participation on design contract awards.

Overall annual designations by awarding authorities, as well as MBE/WBE participation on individual projects with a combined MBE/WBE participation goal, must include a reasonable representation of both MBE and WBE firms that meets or exceeds the combined goal. Proposed MBE/WBE participation plans that include solely MBE or solely WBE participation, or do not include a reasonable amount of participation by both MBE and WBE firms to meet the combined goal, will not be considered responsive. Where the prime contractor or designer is an SDO certified MBE or WBE, the prime must bring a reasonable amount of participation by a firm or firms that hold the certification which is not held by the prime contractor or designer on the project. Proposed participation on construction projects or design projects which consists solely of either an MBE or WBE representing 100% of the overall combined goal will not be considered reasonable participation. The SDO and DCAM will determine whether there is reasonable participation by both MBE and WBE firms on individual projects under their

respective oversight. Firms submitting MBE/WBE participation plans which do not provide reasonable participation by both MBE/WBE firms shall be provided an opportunity to revise and resubmit their plans within the time frame set by the awarding authority; however no price adjustments shall be permitted as a result of the revised plan. Firms failing to submit an MBE/WBE participation plan deemed reasonable and accepted by the awarding authority shall not be awarded the contract.

Participation by MBE and WBE firms must be documented, tracked and reported on separately as MBE participation and WBE participation by prime vendors, subcontractors and awarding authorities.

22) THE CITY OF WALTHAM EQUAL EMPLOYMENT OPPORTUNITY AND AFFIRMATIVE ACTION POLICY

The City of Waltham is committed to a policy of equal employment opportunity and to a program of affirmative action in order to fulfill that policy. The City will accordingly recruit and hire into all positions the most qualified persons in light of job-related requirements, and applicants and employees shall be treated in employment matters without regard to unlawful criteria including race, color, religion, ancestry, national origin, sex, sexual orientation, disability, age, positive HIV-related blood test results, status as a disabled or Vietnam Era Veteran, genetic information, or gender identity or expression, as these terms are defined under applicable law, or any other factor or characteristic protected by law.

In addition, The City of Waltham recognizes that discriminatory harassment and sexual harassment are forms of unlawful discrimination, and it is, therefore, the policy of the City of Waltham that discriminatory harassment and sexual harassment will not be tolerated. The City of Waltham also prohibits unlawful harassment on the basis of other characteristics protected by law.

Further, employees and applicants will not be subjected to harassment or retaliation because they have engaged in or may engage in the following: filing a complaint or assisting or participating in an investigation regarding alleged discrimination or harassment as prohibited in the policy statement above; filing a complaint or assisting or participating in an investigation, compliance evaluation, or any other activity related to the administration of the Vietnam Era Veterans' Readjustment Assistance Act of 1974 ("VEVRAA"), Section 503 of the Rehabilitation Act of 1973 ("Rehabilitation Act"), or the Affirmative Action provisions of federal, state or local law; opposing any act or practice made unlawful by VEVRAA requiring equal employment opportunities for individuals with disabilities, disabled veterans, or veterans of the Vietnam Era; or exercising any rights under VEVRAA or the Rehabilitation Act.

Sources: Titles VI and VII of the Civil Rights Act of 1964; the Immigration Reform and Control Act of 1986; Title IX of the Education Amendments of 1972; the Equal Pay Act of 1963; the Age Discrimination in Employment Act of 1967; the Age Discrimination Act of 1975; Sections 503 and 504 of the Rehabilitation Act of 1973; the Americans with Disabilities Act of 1990; Section 402 of the Vietnam-Era Veterans Readjustment Assistance Act of 1974; Executive Order 11246 as amended; The Genetic Information Nondiscrimination Act of 2008 and such other federal, state and local non-discrimination laws as may apply.

23) BUY RECYCLING REQUIREMENTS

The City of Waltham's Buy Recycling Procedure follows the EPA's Comprehensive Procurement Guideline (CPG) program promoting the use of materials recovered from solid waste. Buying recycled-content products ensures that the materials collected in recycling programs will be used again in the manufacturing of new products. The City requires that the purchase of products and material supplied by subcontractors originate, as often as practical, from the recycling of previously used materials.

CITY OF WALTHAM, MASSACHUSETTS
CONSOLIDATED PUBLIC WORKS DEPARTMENT

7 - TECHNICAL PROVISIONS
FOR
ANNUAL CONTRACT FOR
RESURFACING OF BITUMINOUS ROADWAYS AND REPAIRS TO SIDEWALKS
IN
WALTHAM, MASSACHUSETTS

CLEARING AND GRUBBING

General: This work shall consist of clearing, grubbing, cutting, removal and disposal of all vegetation and debris from areas either within or outside of the Right-of-Way as shown on the plans or designated by the Engineer. The work shall also include the preservation from injury or defacement of all vegetation and objects designated by the Engineer to remain.

The burning of trees, brush, stumps, etc., will not be permitted. The Contractor shall provide other satisfactory methods of disposal without additional compensation.

Quality of Work: Quality of work must conform to all accepted tree trimming practices. All trimming and pruning shall conform to recognize tree surgery practices, and particular note should be made that painting with an approved tree dressing or paint, will be required on all cuts 2 inches or over in diameter.

The dressing or paint shall be applied no later than two days after the cuts are made.

Recognized tree surgery practices include among others, the fact that all limbs and branches which require removal and all stubs regardless of age must be cut flush either to a union with the next larger sound limb or branch or flush to the trunk of the tree.

The cutting shall be performed by experienced woodsmen. Trained tree climbers are required for pruning of tall growth. Care shall be exercised by the Contractor to prevent injury to trees and shrubs designed to be preserved. Any injury to limbs, bark or roots of such plants shall be repaired by the Contractor, as directed, or the plants replaced without additional compensation for such repair or replacement.

Disposal of Trees: All trees to be cleared shall become the property of the Contractor, and the satisfactory disposal of the wood in such trees outside the Right-of Way shall become his responsibility.

The tress, including cuttings and slash shall be disposed after cutting as soon as practicable and in such a manner as not to distract from the appearance of the roadside.

If the existing ground in the area is disturbed by any of the work or equipment, the Contractor shall rough-grade and loam and seed if necessary the disturbed areas, if so directed, without additional compensation.

Payment Items

103.000	Tree removed (diameter under 24 Inches)	Each
104.000	Tree removed (diameter Over 24 Inches)	Each

DISPOSAL OF STUMPS AND BRUSH

General

Disposal of Stumps and Brush: After removal, all stumps including the major root system shall be disposed by the Contractor at his own responsibility outside the layout where the material will not cause obstructions to streams and will not detract from the appearance of the roadside.

Disposal of Dutch Elm Diseased Wood: Dutch Elm diseased wood shall be disposed of in accordance with the provisions of General Law, Chapter 87, Section 5 and Chapter 132, Sections 8 and 11, as amended; and in accordance with any additional local regulations.

Where the work includes the removal of elm trees or the limbs of elm trees, such trees or limbs thereof shall be disposed of immediately after cutting or removal and in such a manner as to prevent the spread of Dutch elm disease. This shall be accomplished by covering them with earth to a depth of at least 6-inches in areas outside the highway location where the Contractor has arranged for disposal.

Where the work includes the removal and disposal of stumps of elm trees, such stumps shall be completely disposed of immediately after cutting in the manner specified above.

Method of Measurement: Only such trees as have a shortest diameter of at least 9-inches and less than 24-inches shall be included in the item of Trees Removed (Diameter Under 24-Inches). Only such trees as have a shortest diameter of 24- inches or more shall be included in the item of Trees Removed (Diameter 24 Inches and Over).

The item of Stumps Removed shall include the removal and satisfactory disposal of all tree stumps which remain in their original position and 9 –inches or more in shortest diameter at the cutoff point, where the trees have been previously removed by others. A stump shall not be construed as a tree under these specifications unless the trunk extends over 6-feet above the average ground.

Trees or stumps to be removed which have the shortest diameter specified for payment will be measured in place by the following procedure.

Where the tree consists of a single trunk extending more than a 3-foot vertical height above the average natural ground line, the shortest diameter shall be measured at the 3-foot level above the average elevation of the original ground.

Any tree whose main trunk separates into multiple trunks or which has limbs or branches growing out from the main trunk below the 3-foot level defined hereinbefore shall have its shortest diameter measure at the lowest point on the main trunk where multiple growths or branching out begins.

Measurement for payment under the respective items shall be such that any individual growth to be classed as a tree stump shall be measured in a manner to limit payment to one single tree or stump at each particular location of the individual growth. When multiple trunks with a common root system are

separated at ground level each separate trunk shall be considered as an individual growth under these specifications.

The quantity of trees or stumps to be paid for will be the number actually removed by the Contractor in the completed and accepted work as determine by count.

The removal of trees, including the stumps thereof and required spray material will be paid for at the contract unit price each for the particular kind of work involved, as defined hereinbefore when a quantity is given in the Proposal under their respective items, otherwise this work will be paid for at the contract unit price for excavation or at the contract unit price per acre of Clearing and Grubbing or Selected Clearing and Thinning, whichever is applicable. The contract unit price shall include the cost of all arrangements and methods required to protect from harm all existing overhead or underground installations. The contract unit price for the respective items shall not include any tees or stumps removed from the area paid for under the item of Clearing and Grubbing or Selected Clearing and Thinning.

Only such trees or stumps as have a shortest diameter of 9-inches and over, measured as stipulated in Sub-section 101.80 shall be included for payment.

Payment Items

105.000	Stump Removed	Each
---------	---------------	------

UNCLASSIFIED EXCAVATION

GENERAL: This work shall consist of the necessary excavation and removal of various materials as shown on the contract drawings or as required by the OWNER. All work shall be done by the CONTRACTOR. All excavated material shall be disposed of in a proper manner. All material shall be cleaned up by the CONTRACTOR as the work progresses. No material or waste shall be left on the street overnight and no driveways or sidewalks shall be left in a rough or unsafe condition unless lighted and guarded by the CONTRACTOR at his expense. Where abutting lawns are cut, the CONTRACTOR must properly adjust and reseed the lawn to the new grade. Where abutting surfaces of blacktop or other material are disturbed beyond the limit of adjustment, the CONTRACTOR shall replace same at his own expense.

Excavation shall include the removal and disposal of bituminous, earth, curbing, signposts, and/or any incidental items as indicated on the contract drawings or as required by the OWNER. Items and/or materials that are classified for payment under some other unit item within this contract shall not be considered as part of ITEM 120.100.

The edges of existing concrete surfaces that are to receive new replacement materials shall be saw-cut along even lines and shall be cut back to obtain clean, sound vertical edges of the abutting material.

The edges of bituminous concrete shall be saw-cut or cut with pneumatic tools along even lines and shall be cut back to obtain clean, sound vertical edges of the abutting material. All edges shall be coated with an approved bituminous material for proper bonding of new pavement construction with the existing pavements. All preparation of edges of existing pavements shall be provided as specified herein and shall be subject to approval by the OWNER.

The City of Waltham, at its own discretion, may retain the right to the excavated gravel and the OWNER may select a site for said gravel to be placed. On-site gravel, if requested by the OWNER, shall be saved for re-use on the job. The gravel shall be excavated separately from the bituminous, stored (if required) and/or relocated on the site or at a site within the city selected by the OWNER, at no additional cost to the City of Waltham. All work shall be done by the CONTRACTOR.

If requested by the OWNER, any suitable excess material (as determined by the OWNER) excavated from the site shall be re-used to fill areas below subgrade. This shall be done at no extra cost to the City.

All saw-cutting of materials shall be done at no extra cost and shall be considered as incidental to the item unless there is a separate and/or specific pay item listed for saw-cutting in the Contract.

CONTRACTOR shall avoid damage to trees that have parts of their root system in the roadway, sidewalk or planting areas that are selected for excavation. Said excavation shall be accomplished as carefully as possible or as required by the OWNER.

NOTE: Material excavated during reclamation or cold planing operations is not included in this item.

MEASUREMENT: Measurement for unclassified excavation shall be the number of cubic yards of material removed and legally disposed of. This quantity shall be based on the OWNER'S field measurements and/or office calculations.

Failure to allow ample time for the OWNER to make the required measurements will forfeit the CONTRACTOR'S right of claim to any excavation other than that allowed by the OWNER.

PAYMENT: Payment for unclassified excavation shall be made for the number of cubic yards of material removed and disposed of as determined above at the contract unit Bid price for ITEM 120.100 as set forth in the Bid. Unless it is classified for payment under some other unit item within this contract, saw-cutting of pavements shall be considered as incidental to the work and shall be included within the unit price for unclassified excavation.

Payment Items

120.100	Unclassified Excavation	Cubic Yards
121.000	Class A Rock Excavation and Refill	Cubic Yards
123.200	Muck Excavation & Refill (trench)	Cubic Yards
127.000	Concrete Excavation	Square Yards

CONCRETE SIDEWALK EXCAVATION

GENERAL: This work shall consist of all necessary excavation and disposal of existing concrete surfaces as shown on the Contract Drawings or as specified by the OWNER. All work shall be done by the CONTRACTOR and the material shall be cleaned up as the work progresses. No material or waste shall be left on the street overnight and no driveway or sidewalk shall be left in an unsafe condition unless lighted and guarded by the CONTRACTOR at his expense. Where abutting surfaces of concrete or material are disturbed beyond the limits of adjustment or beyond the limits of contract, the CONTRACTOR shall replace the same at his own expense. If reinforced concrete walks and/or drives are encountered during removal, they shall be included as part of this item. The edges of existing concrete surfaces that are to receive new replacement materials shall be saw-cut along even lines and shall be cut back to obtain clean, sound vertical edges of the abutting material.

All saw-cutting of concrete shall be done at no extra cost and shall be considered as incidental to the work within this item unless there is a separate and/or specific pay item listed for saw-cutting elsewhere in this contract.

MEASUREMENT: Measurement shall be the number of square yards removed and disposed, regardless of the depth of concrete excavated, in a manner satisfactory to the OWNER. This quantity shall be measured in the field by the OWNER.

Failure to allow ample time for the OWNER to make the required measurements will forfeit the CONTRACTOR'S right-of-claim to any concrete excavation other than that allowed by the OWNER.

PAYMENT: Payment shall be made for the number of square yards of concrete removed, regardless of depth, based on the OWNER'S field measurements. Payment shall be at the Contract unit price for ITEM 127.000 as set forth in the Bid. Saw-cutting shall be considered as incidental to the work within this item. No separate payment shall be made for saw-cutting concrete unless otherwise specified elsewhere within this contract.

Payment Items

127.000	Concrete Sidewalk Excavation	Square Yards
120.100	Unclassified Excavation	Cubic Yards

COLD PLANING

GENERAL: This work shall consist of the cold planing of bituminous concrete roadway surfaces to various depths up to 6 inches to produce a uniform surface for the application of a bituminous overlay as required by the OWNER. The CONTRACTOR shall cold plane the bituminous concrete surface to the depths, widths, grades and cross sections as indicated and/or as required by the OWNER. Material removed shall be disposed of legally and off the site.

METHOD: Catch basins shall be protected during the cold planing process by inserting silt fabric between each frame and grate. The fabric shall be removed immediately after all cuttings have been removed. Any cuttings that fall into the catch basin shall be removed by the CONTRACTOR.

The bituminous concrete surface shall be planed and profiled by a power operated planing machine or a grinder capable of removing, in one pass, a layer of bituminous concrete nine feet. The equipment shall be self-propelled with sufficient power traction and stability to maintain accurate depth of cut and slope and shall be equipped with all necessary safety devices such as flashing lights and back-up signals so as to operate in traffic with complete safety. The equipment will be capable of accurately and automatically establishing profile grades along each edge of the machine by referencing from the existing pavement or from an independent grade control and shall have an automatic system for controlling cross slope at a given rate.

All planing machinery shall be equipped with dust control devices to prevent any dust produced in the cutting operation from escaping into the air. Dust control equipment must comply with EPA air quality standards.

The CONTRACTOR shall also have the necessary auxiliary grinding or milling machinery to perform the required cutting and trim cutting around castings. Pneumatic rubber-tire mounted equipment shall be used only for trimming and edging operations.

The cold plane cuttings from the operation shall be discharged directly from the planer into the CONTRACTOR'S trucks and legally disposed of off the site by the CONTRACTOR in a manner acceptable to the OWNER. Unless otherwise specified by the OWNER, the materials shall become the property of the CONTRACTOR. Loose materials left on the roadway surface as a result of the cold planing operations shall be removed and disposed of by the CONTRACTOR in the same manner as the planed material.

All excess material shall be removed from the site as part of this item. **There is no additional measurement or payment for excavation.**

MEASUREMENT: Measurement for cold planing shall be for the number of square yards of material removed and disposed of, regardless of depth, as accepted and measured by the OWNER.

PAYMENT: Payment for cold planing shall be made for the number of square yards of materials cold planed and removed and properly disposed of, regardless of depth, as determined above at the contract unit price for ITEM 129.010 as set forth in the Bid. Said price and payment shall be full compensation for furnishing all equipment, labor, materials, tools, and all else incidental and necessary for the satisfactory completion of this work.

	<u>Payment Item</u>	
129.010	Cold Planing	Square Yards

GRAVEL BORROW

GENERAL: This work shall consist of furnishing and placing ordinary gravel borrow in accordance with these Specifications, and/or as required by the OWNER.

MATERIALS: Gravel borrow shall consist of hard durable stone and coarse sand free from loam and clay, well graded and containing no stone having any dimension greater than two (2) inches (type C), as per Section M1.03.0 of the Commonwealth of Massachusetts Standard Specifications, including any and all addenda. The gravel borrow shall conform to the following sieve requirements:

<u>SIEVE</u>	<u>% PASSING</u>
1/2"	50 - 85
#4	40 - 75
#50	08 - 28
#200	0 - 08

The gravel shall be tested for sieve analysis at the plant prior to delivery on the job site. The written results shall be given to the inspector for the city for approval prior to delivery. Failure to do so may result in the refusal of the material by the City. All costs incurred shall be paid for by the CONTRACTOR at no cost to the City.

The gravel borrow shall be placed in six inch (maximum) layers and then compacted to not less than 95% of maximum optimum density as determined by AASHTO Test Designation: T99-57, Method C.

Crusher run may be substituted in place of gravel borrow if desired by the CONTRACTOR and so approved by the OWNER. Crusher run shall be paid for at the same unit price as gravel borrow. The conversion factor used in determining the quantity of crusher run substituted shall be one and one-half tons of crusher run is equivalent to one cubic yard of crusher run.

MEASUREMENT: Measurement for gravel borrow shall be the number of cubic yards furnished, placed, and accepted in accordance with these specifications and/or as required by the OWNER. The number of cubic yards in place and accepted shall be measured or calculated by the OWNER. Fifteen percent shall be added to the figure for compaction. Only gravel borrow placed within the established pay limit necessary to complete the work as required by the OWNER shall be considered for payment. If, in the opinion of the OWNER, the CONTRACTOR has excavated areas to an excessive width and/or depth, either through error or for his own convenience, the gravel borrow used to refill trenches beyond said reasonable width or depth shall be paid for by the CONTRACTOR with no cost to the City.

Failure to allow the OWNER ample time to make the required measurements will forfeit the CONTRACTOR'S right of claim to any gravel borrow other than that which is allowed by the OWNER.

PAYMENT: Payment for gravel borrow shall be made for the number of cubic yards furnished, placed, and accepted as determined above at the contract unit prices for ITEMS 151.000 & 151.220 as set forth in the Bid. Said price and payment shall be full compensation for furnishing and placing all materials, all equipment, tools, labor, backfilling operations and all else incidental thereto. Fine grading and compaction shall be paid for under the applicable item of finish material (bituminous concrete or cement concrete).

On-site gravel, if requested by the OWNER, shall be saved for re-use on the job. The gravel shall be excavated, stored (if required), and/or relocated on the site, all at no additional cost to the City. All work shall be done by the CONTRACTOR.

Payment Items

151.220	Gravel Borrow (Trench Repair, Sidewalks & Drives)	Cubic Yards
---------	---	-------------

CRUSHER RUN

GENERAL: This work shall consist of the furnishing and placing of a one-inch leveling layer of crusher run as required by the OWNER. Depth of crusher run shall be measured after compaction. Crusher run may also be provided as a base for granite curb if required by the OWNER.

MEASUREMENT: All crusher run used will be paid for on the basis of weight and shall be measured by tickets delivered with each load. The tickets shall clearly show the total, tare, and net weights. Loads represented by tickets not showing the weights as specified above will not be accepted for payment. Only crusher run placed at the required depth and within the limits specified will be accepted for payment.

PAYMENT: Payment for crusher run shall be made for the number of tons as determined above at the contract unit price for ITEM 151.900 as set forth in the Bid. Said price and payment shall be full compensation for furnishing and placing of crusher run, and for furnishing all tools, labor, equipment and all else incidental thereto. Fine grading and compaction of crusher run shall be paid for under the applicable item of finish material (bituminous or cement concrete).

Payment Item

151.900

Crusher Run

Tons

SAND BORROW

GENERAL: This work shall consist of furnishing and mixing sand borrow as an additive for reclamation applications.

MEASUREMENT: Sand borrow will be paid for on the basis of weight and shall be measured by tickets delivered with each load. The tickets shall clearly show the total, tare, and net weights. Loads represented by tickets not showing the weights as specified above will not be accepted for payment.

PAYMENT: Payment for sand shall be made for the number of tons as determined above at the contract unit price for ITEM 154.001 as set forth in the Bid. Said price and payment shall be full compensation for furnishing and placing of sand, and for furnishing all tools, labor, equipment and all else incidental thereto.

Payment Item

154.001	Sand Borrow	Tons
---------	-------------	------

DRAINAGE STRUCTURE ADJUSTED

GENERAL: This work shall consist of adjusting OWNER’S existing frames and grates or covers of manholes and catch basins to newly proposed line and/or grade changes. This item shall not apply to any new castings installed under item 222.010 or castings for new structures. When the line and/or grade of an existing structure require a change of more than one foot vertically and/or horizontally, the structure shall be remodeled under ITEM 220.500.

METHOD: Frames shall be set in full mortar beds true to the lines and grades established by the OWNER. All voids beneath the bottom flange shall be entirely filled to make a water-tight fit. A ring of mortar at least one inch thick shall be placed around the outside of the bottom flange and shall extend to the outer edge of the masonry structure.

After frames have been set and mortared, a cement concrete collar shall be constructed to the dimensions shown on the detail plans of the contract drawings. Cement concrete shall be 3000 psi with ¾ inch stone. All work shall be done under the direction of the OWNER.

PAYMENT: Measurement for drainage structures adjusted shall be made based on a complete and accepted unit as determined from actual count by the OWNER.

Payment shall be made for each completed unit as determined above at the contract unit price for ITEM 220.000 as set forth in the Bid. Said price and payment shall be full compensation for all work including labor, materials, tools, equipment, mortar, brick, gravel, collars and all else necessary for final and satisfactory completion of the work within this item.

Payment Items

220.000	Drainage Structure Adjusted	Each
220.500	Drainage Structure Remodeled	Vertical Foot
222.010	Frame and Grate or Cover	Each

FRAME & GRATE OR COVER (IN-PLACE)
(MUNICIPAL STANDARD or MHD CASCADE TYPE)

GENERAL: This work shall consist of furnishing, setting and adjusting to final grade any new castings as required.

When existing castings, in the opinion of the OWNER, are found to be defective through no fault of the CONTRACTOR, they shall be removed and disposed of by the CONTRACTOR. A new complete casting shall then be furnished, installed and adjusted to final grade by the CONTRACTOR as required by the OWNER.

Any casting damaged by the CONTRACTOR through his own negligence shall be replaced by him at no additional cost to the City.

MATERIALS: For catch basins, the frames shall conform to East Jordan Iron Works (EJIW) type 5546Z FLG3 (3 flange when curbing is present, 4 flange if there is no curbing) or the equivalent. Grates shall conform to EJIW type 5520M5 for standard grates.

For manholes, the frames shall conform to EJIW type 1246 or the equivalent. Covers shall conform to EJIW type 1248A or the equivalent. When ordering the covers, specify whether the top is to be lettered as "SEWER" or "DRAIN".

METHOD: Frames shall be set in full mortar beds true to the lines and grades established by the OWNER. All voids beneath the bottom flange shall be entirely filled to make a water-tight fit. A ring of mortar at least one inch thick shall be placed around the outside of the bottom flange and shall extend to the outer edge of the masonry structure.

MEASUREMENT AND PAYMENT: Measurement for frames and grates or covers shall be made for the number of units furnished, placed, adjusted to final grade and accepted as determined from actual count by the OWNER. Payment shall be made based on the number of completed units as determined above at the contract unit price for ITEMS 222.010 & 222.030 as set forth in the Bid. Said price and payment shall be full compensation for furnishing, setting and adjusting all castings, for materials including mortar, bituminous, red clay bricks, gravel, and for all tools, labor, equipment and all else incidental to the work within this item. There shall be no payment under this item for existing castings or for new or proposed castings that are being paid for as part of some other item within this contract.

Payment Items

222.010	Frame and Grate or Cover (In-Place)(Municipal Standard)	Each
222.030	Frame and Grate or Cover (In-Place)(MHD Cascade Type)	Each

GATE BOXES

GENERAL: This work shall consist of furnishing and installing gate boxes as shown on the contract drawings or as required by the OWNER.

Gate boxes shall be two section, cast iron, heavy pattern, adjustable type with cast iron cover. The upper section shall have a bottom flange of sufficient bearing area to prevent settling. The bottom section shall enclose the valve stuffing box and operating nut. Boxes shall be of lengths adapted to five foot pipe cover or more and have a minimum of six inch overlap in the most extended position. Covers shall have the word "WATER" cast in the top.

The box shall be installed vertically and centered over the gate so that the gate wrench may be easily attached onto the gate. After installation, the box shall be cleaned out of all residue. Also included with this item shall be the final adjustment to proposed grade of the new gate box.

MEASUREMENT: Measurement for gate boxes shall be for the number of units furnished, installed and accepted as measured by the OWNER.

PAYMENT: Payment for gate boxes shall be made for the number of units furnished, installed and accepted as determined above at the contract unit prices for ITEMS 357.040, 357.041, 357.060 and 357.061 as set forth in the Bid. Said price and payment shall be full compensation for furnishing and installing gate boxes and all related work including excavation, pumping, backfill, cement concrete collars, cleaning out the gate box, all tools, labor, equipment, materials and all else incidental to complete the work within this item. There shall be no separate payment for adjustment of new gate boxes and sleeves. That work shall be considered as incidental to the work within this item.

Payment Items

357.040	4" Service Gate Box	Each
357.041	4" Service Gate Box (Upper Sleeve Only)	Each
357.060	6" Service Gate Box	Each
357.061	6" Service Gate Box (Upper Sleeve Only)	Each

ADJUSTMENT OF GATE BOXES

GENERAL: This work shall consist of raising the OWNER’S existing water gate and water service gate boxes to newly proposed grades. Prior to adjustment of the gate boxes, the vertical alignment of the box over the center of the gate shall be checked. If needed, the gate box shall be re-aligned over the top of the gate before it is adjusted. Gravel base around the gate boxes shall be thoroughly compacted. For gate boxes in the traveled roadway, the excavated area shall be refilled with gravel, compacted, and set in a cement concrete collar as shown on the detail section of the contract drawings. The final elevations of the structures shall be determined in the field by the OWNER at the time of construction. All work shall be done under the direction of the OWNER. After the boxes are adjusted, they shall be air blown to remove all debris from the inside.

If, during the course of the work, a defective gate box is encountered, the CONTRACTOR shall remove it as required by the OWNER. A new gate box and/or sleeve shall be furnished and installed by the CONTRACTOR. This shall not include any gate boxes and/or sleeves damaged by the CONTRACTOR. Any damage as a result of the CONTRACTOR'S negligence shall be repaired or replaced by him at no cost to the City. Furnishing, installation and adjustment to final grade of any new gate boxes and/or sleeves shall be included as part of ITEMS 357 and shall not be considered as part of ITEMS 358.100 or 358.200.

MEASUREMENT: Measurement for gate boxes adjusted shall be for the number of units completed and accepted as determined from actual count by the OWNER.

PAYMENT: Payment for gate boxes adjusted shall be made based on the number of completed units as determined above at the contract unit prices for ITEMS 358.100 & 358.200 as set forth in the Bid. Said price and payment shall be full compensation for all work in adjusting gate boxes and/or sleeves including all tools, labor, equipment, cement concrete collars, gravel, compaction, and all else incidental to satisfactorily complete the work within this item. Not included for payment within this item shall be the furnishing, installation, and final adjustment to grade of any new gate boxes and/or sleeves that are required. They shall be measured and paid for under ITEMS 357.

Payment Items

358.100	Adjustment of Gate Boxes (Sidewalk)	Each
358.200	Adjustment of Gate Boxes (Roadway)	Each

PAVEMENT RECLAMATION

GENERAL: This work will consist of in-place rehabilitation of the existing pavement structure. Existing pavement shall be scarified, pulverized and reshaped into a processed asphalt stabilized base.

MATERIALS: If additional fine material is required to attain the specified gradation, it will be added as required by the OWNER and paid under item 154.001.

METHODS: The existing asphalt structure shall be scarified and mixed with equal amounts of gravel base from the existing roadway foundation to a maximum depth of 16". The pulverization shall be accomplished by means of a traveling pulvimiller/hammermill or equivalent machine capable of scarifying/milling to a depth of 16" in one pass and conveying this material to a stationary hammermill mounted on the machine. This machine shall be self-propelled and equipped with an adjustable grading blade thus leaving its path generally smooth for traffic. The key element in this process is the fractioning of the existing asphalt pavement by the high speed hammers of the hammermill. Equipment such as road planers/cold milling machinery will not be acceptable as they produce larger asphalt particle size that defeats the objective of this process. The above mentioned process shall produce a uniformly blended base material with a minimum asphalt content of 2% that will conform to the following gradation requirements:

<u>Sieve Designation</u>	<u>Percentage by Weight Passing</u>
3"	100%
1 1/2"	70-100%
3/4"	55-90%
#40	10-30%
#200	1-3%

After the material has been accepted by the OWNER, it shall be shaped, graded and rolled to true grades, the prescribed number of inches below and parallel to the finish pavement grade of the roadway as shown on the plans or as required by the OWNER. Material not required in the roadway shall be deposited and spread on the sidewalk by the CONTRACTOR as required at no additional cost to the City. Excess material that is not needed on this project shall be removed and properly disposed of by the CONTRACTOR at no additional cost to the City.

Water shall be applied during the operation in sufficient quantities to insure optimum moisture content at the time of compaction. Water may be taken from City hydrants provided an approved hydrant wrench and control valve are used, and that water is not wasted.

MEASUREMENT: Measurements shall be taken by the OWNER with the process material in place and properly graded and compacted. Measurement shall be the number of square yards reclaimed for any depth up to sixteen inches.

All excess material shall be removed from the site as part of this item. **There is no additional measurement or payment for excavation.**

PAYMENT: Payment shall be made for the number of square yards reclaimed as determined above, up to a depth of sixteen inches, at the contract unit price for ITEM 403.001 as set forth in the Bid. Said price and payment shall be full compensation for reclaiming, processing, rough grading, compacting, depositing and grading on sidewalk, removal of excess material, labor, materials, tools and equipment and all incidentals necessary to complete the work under this item as shown on the plans, as required by the OWNER, and as specified herein.

Payment Items

403.001	Reclamation	Square Yards
154.001	Sand	Tons

TRENCH REPAIR

GENERAL: This work shall consist of repairing temporary trench patches throughout the city which were previously installed by others. Work shall include saw cutting and excavation of the temporary patch, compacting the sub grade, applying a 1½” binder course and returning on the following day to apply a 1½” wearing course. Trenches are generally 100 to 400 square feet and a located throughout the city.

MATERIALS: Class I bituminous concrete pavement, Type I-1, shall conform to the requirements of Section 560.00 of the current Edition of the "Standard Specifications for Highways and Bridges," Commonwealth of Massachusetts, Department of Public Works, including any addenda or amendments thereto.

Bituminous concrete shall be spread at a temperature of not less than 225 degrees Fahrenheit and all initial rolling or tamping shall be performed when the temperature of the mixture is such that the sum of the air temperature plus the temperature of the mixture is between 300 and 375 degrees Fahrenheit. All mixtures shall be placed only when the atmospheric temperature is above 40 degrees Fahrenheit.

Bituminous concrete for wearing surfaces and base courses shall be spread in individual layers and compacted to the required lines, grades and cross section. Each completed surface shall be thoroughly compacted, smooth and free from ruts, humps, depressions, or irregularities. Where new bituminous meets existing bituminous surfaces, an emulsifying agent shall be applied to seal the joint. A sand overcoat shall then be applied over the emulsifying agent.

MEASUREMENT: All bituminous used for trench repair shall be paid for on the basis of square yards as measured by the OWNER. Only bituminous concrete placed at the required depth and within the limits specified by the OWNER will be accepted for payment.

PAYMENT: Payment for Trench Repair shall be made for the number of square yards as determined above at the Contract unit price for ITEM 405.000 as set forth in the Bid. Said price and payment shall be full compensation for all saw cutting, excavation and disposal, fine grading and compaction, spreading and compacting bituminous concrete, emulsifying and sanding of all joints, and for furnishing all tools, labor, materials, equipment, and all else incidental thereto.

Payment Item

405.000

Trench Repair

Square Yard

CALCIUM CHLORIDE FOR DUST CONTROL

GENERAL: This work shall consist of furnishing and applying approved dust control material to the surface of the sub grade or elsewhere as required by the OWNER.

MATERIALS: Calcium Chloride shall conform to the requirements of AASHO M144, Type I or Type II.

APPLICATION: Calcium Chloride shall be uniformly applied at the rate of three-quarters pounds per square yard or as required by the OWNER.

MEASUREMENT: Calcium Chloride will be measured by the pound and the quantity to be paid for shall be the actual weight of the material furnished and applied in place.

PAYMENT: Payment shall be made for the amount of Calcium Chloride furnished and placed as determined above at the Contract price for ITEM 440.000 as set forth in the Bid.

<u>Payment Item</u>		
440.000	Calcium Chloride	Pounds

CLASS I BITUMINOUS CONCRETE (ASPHALT)

GENERAL: This work shall consist of fine grading and compaction of gravel base material and/or crusher run base material prior to placing mix, and furnishing, spreading and compacting bituminous concrete base courses and wearing surfaces in accordance with the details shown on the Contract Drawings, as specified in these Specifications, or as required by the OWNER.

MATERIALS: Class I bituminous concrete pavement, Type I-1, shall conform to the requirements of Section 560.00 of the current Edition of the "Standard Specifications for Highways and Bridges," Commonwealth of Massachusetts, Department of Public Works, including any addenda or amendments thereto. The City of Waltham has the option of requesting a modified state top when deemed necessary.

Bituminous concrete shall be spread at a temperature of not less than 225 degrees Fahrenheit and all initial rolling or tamping shall be performed when the temperature of the mixture is such that the sum of the air temperature plus the temperature of the mixture is between 300 and 375 degrees Fahrenheit. All mixtures shall be placed only when the atmospheric temperature is above 40 degrees Fahrenheit.

Bituminous concrete for wearing surfaces and base courses shall be spread in individual layers and compacted to the required lines, grades and cross section.

Rolling shall commence at the lower edges and shall progress toward the highest portion. Under no circumstances shall the center be rolled first. Each completed surface shall be thoroughly compacted, smooth and free from ruts, humps, depressions, or irregularities.

Where new bituminous meets existing bituminous surfaces, an emulsifying agent shall be applied to seal the joint. A sand overcoat shall then be applied over the emulsifying agent.

MEASUREMENT: All bituminous used for roadway and sidewalk bases and surfaces will be paid for on the basis of weight and shall be measured by tickets delivered with each load. The tickets shall be signed by a certified weigher and shall be countersigned by the OWNER. The tickets shall clearly show the total, tare, and net weights. Loads represented by tickets not showing the weights as specified above will not be accepted for payment. Only bituminous concrete placed at the required depth and within the limits specified by the OWNER will be accepted for payment.

PAYMENT: Payment for bituminous concrete shall be made for the number of tons as determined above at the Contract unit price for ITEMS 460.000, 460.100 and 460.300 as set forth in the Bid. Said price and payment shall be full compensation for all fine grading and compaction, for furnishing, spreading and compacting bituminous concrete, emulsifying and sanding of all joints, and for furnishing all tools, labor, materials, equipment, and all else incidental thereto.

Payment Items

460.000	Class I Bituminous Concrete Type I-1 (Roadway)	Tons
460.100	Class I Bituminous Concrete Type I-1 (Sidewalks, Drives, Permanent Patching & Adjustment. Areas)	Tons
460.300	Class I Bituminous Concrete Type I-1 (Roadway) Night Work	Tons

BITUMEN FOR TACK COAT

GENERAL: This work shall consist of furnishing and placing of a bituminous tack coat prior to the placement of Class I bituminous concrete for resurfacing. All work and materials shall be furnished and placed by the CONTRACTOR.

MATERIALS AND METHODS: Bituminous tack material shall conform to the requirements of Section M3.03.0 of the current Edition of the "Standard Specifications for Highways and Bridges," Commonwealth of Massachusetts.

The application shall be done by means of an approved mechanical pressure distributor tanker truck only with a heating device capable of heating the material evenly up to a temperature of 425° Fahrenheit. It shall also be equipped with a distribution spray bar of a type that will distribute the bituminous tack material uniformly under a pressure of not less than 30 lbs. per square inch, without streaks and/or spots, so as to provide an equal and uniform coverage on the existing surface. The tanker truck shall be equipped with a gauge to accurately measure the gallons applied. The tanker truck shall also be so designed as to enable the operator to control the rate of flow and to provide a positive cut-off to prevent dripping of the nozzles when shut off. The bitumen shall be applied at a rate as described above.

The application rate for the bitumen shall be 15 square yards per gallon.

MEASUREMENT: Measurement for bitumen for tack coat shall be for the number of gallons actually furnished, placed and accepted as determined by the OWNER and/or his representative. The OWNER and/or his representative may elect to use the measured amount from printout slips of actual gallons used as received from the tanker truck.

PAYMENT: Payment for bitumen for tack coat shall be made for the number of gallons furnished, placed and accepted as determined above at the Contract unit price for ITEMS 464.000 as set forth in the Bid. Said price and payment shall be full compensation for furnishing and placing all materials and for furnishing all tools, equipment, labor, and all else incidental thereto to complete the work within this item.

Payment Item

464.000

Bitumen for Tack Coat

Gallons

BITUMINOUS CONCRETE CURB

GENERAL: This work shall consist of furnishing and placing bituminous concrete curb in accordance with these specifications or as required by the OWNER.

MATERIALS: Bituminous concrete curb, Class I, Type 2, shall conform to Commonwealth of Massachusetts SD106.2.0.

METHODS: On newly constructed roadways, the bituminous concrete curb shall be placed on a bituminous concrete roadway binder course. On existing roadways, the bituminous concrete curb shall be placed on a bituminous concrete pad of top course mix one foot wide by three inches deep at the gutter line in the existing roadway. The bituminous concrete curb shall be placed and compacted by machine. If, at anytime before the acceptance of the work, any soft or imperfect spots develop in the exposed surface of the curb, such material placed shall be removed and replaced with new material and compacted, at no additional cost to the OWNER.

PAYMENT: Payment shall be made for the number of linear feet of bituminous curb placed and accepted by the OWNER as determined above at the Contract unit price for ITEM 470.000 as set forth in the Bid. Said price and payment shall be full compensation for all materials, including bituminous concrete curb mix, all labor, tools, equipment, and related work and all else incidental thereto with the exception of the pad for the curb. The bituminous concrete binder course or the bituminous concrete shall be measured and paid for as part of ITEM 460.000 (binder course) or ITEM 460.100 (bituminous pad), whichever item applies.

Payment Item

470.000	Bituminous Concrete Curb (Class I - Type 2)	Linear Feet
460.000	Class I Bituminous Concrete Type I-1 (Roadway)	Tons
460.100	Class I Bituminous Concrete Type I-1 (Sidewalks, Drives, Permanent Patching & Adjustment Areas)	Tons

GRANITE CURBING

GENERAL: Under these items, the CONTRACTOR is to furnish and install new granite curbing, inlet stones, granite edging and curb corners. Curb shall be set on undisturbed earth to the lines and grades indicated on the Contract drawings and/or as required by the OWNER.

MATERIALS: All new granite curb, curb corners, and inlet stones and granite edging shall conform to the applicable requirements of the "Standard Specification for Highways and Bridges," Commonwealth of Massachusetts, including any addenda or amendments thereto with the exception of payment for crusher run. Crusher run for curbing shall be included as part of the applicable curb item. All granite curbing shall consist of at least ninety percent of six feet minimum lengths unless otherwise required by the OWNER.

Granite curb shall be hard, durable, fine to medium grain and free from seams that impair structural integrity. Color shall be light gray, highlighted by black flakes, similar to that installed on recent projects in Waltham. Curb for each location shall be fabricated from the same parent material by one manufacturer to give a uniform appearance. Natural variations characteristic of the deposit will be permitted. The top of the curb shall be polished. The sides shall be cut square, most specifically the top 6" of the face that faces the street.

Cement concrete shall be 2,500 psi, 3/4" stone.

METHOD: Granite edging shall be set in accordance with the "Commonwealth of Massachusetts Standard Specifications for Highways and Bridges."

A trench shall be excavated to a width of eighteen inches to the bottom of the proposed curb. Unless otherwise required by the OWNER, curb shall be set to the lines and grades shown on the plans and fitted together as closely as possible. Curb shall be saw cut, not broken, to required lengths. If requested by the OWNER, crusher run shall be added and hand tamped to fill any voids between the undisturbed earth and the bottom of the curb so the curb is supported along two points of its entire length. The center and both ends of each curb length shall be left open for cement concrete. On the day of the curb installation, 6" x 6" beds of cement concrete shall be poured front and back, and the concrete shall flow under the curb. Care shall be taken not to affect the line and/or grade of the curb. Joints between curbstones shall be filled with mortar and exposed surfaces shall be neatly pointed. At completion of work, curb shall be clean and free of cement spills. If curb is not clean, the OWNER may request that the curb be pressure washed, at no additional cost to the City.

Care should be taken to avoid placing concrete in areas selected for future placement of trees.

MEASUREMENT: Granite curb to be paid for will be the length actually furnished, set, completed and accepted in accordance with the Specifications and Contract Drawings and as measured along the outer radius of the curb. The quantity of new granite curb corners and inlet stones shall be on a unit basis for the actual number furnished and set in accordance with the Specifications and Contract Drawings.

PAYMENT: Payment for granite curb shall be made as determined above at the Contract unit prices for ITEMS 504.-- as set forth in the Bid. Said price and payment shall be full compensation for furnishing and setting new Type VA4 granite curb, furnishing and setting new Type A curb corners, furnishing and setting new inlet stones, all excavation, backfilling, cement concrete, and for furnishing all labor, tools, equipment, etc., and all else incidental to the satisfactory completion of the work included within these items.

Payment Items

504.000	Granite Curb Type VA4 Straight	Linear Foot
504.100	Granite Curb Type VA4 Curved	Linear Foot
504.110	Granite Curb Type VA4 Curved (Less than 10' radius)	Linear Foot
506.000	Granite Curb Type VB (5"x18")	Linear Foot
506.100	Granite Curb Type VB (5"x18") Curved	Linear Feet
514.000	Granite Inlet Stone Straight	Each
516.000	Granite Curb Corner-Type A (2'-0"radius)	Each
517.000	Granite Curb Corner-Type B (3'-0"radius)	Each
121.000	Class A Rock Excavation	Cubic Yard
151.900	Crusher Run	Tons
515.000	Granite Inlet Stone Curved	Linear Feet

CURB REMOVED AND RESET

GENERAL: This work shall consist of removing existing curb and/or curb corners and resetting them to grade in the same location in accordance with these specifications, as shown on the Contract Drawings, and/or as required by the OWNER. The CONTRACTOR assumes full responsibility for any damages incurred in the removal and resetting processes or any damages incurred while executing said work.

METHODS: Unless otherwise required by the OWNER, curb shall be set to the lines and grades shown on the plans and fitted together as closely as possible. Crusher run shall be added and hand tamped to fill any voids between the undisturbed earth and the bottom of the curb so the curb is supported along two points of its entire length. The center and both ends of each curb length shall be left open for cement concrete. On the day of the curb installation, 6" x 6" beds of cement concrete shall be poured front and back, and the concrete shall flow under the curb. Care shall be taken not to affect the line and/or grade of the curb. Joints between curbstones shall be filled with mortar and exposed surfaces shall be neatly pointed.

MEASUREMENT: Payment for granite curb removed and reset shall be the number of linear feet of curb actually removed and reset as measured and accepted by the OWNER. The quantity of curved granite curb and granite curb corners removed and reset shall be measured along the outer radius.

PAYMENT: Payment for curb and/or curb corners removed and reset shall be made for the number of linear feet of curb and/or curb corners actually removed and reset as determined above at the Contract unit prices for ITEM 580.000 as set forth in the Bid. Said price and payment shall be full compensation for furnishing all labor, tools, equipment, excavation, gravel borrow, backfill, and all else incidental thereto.

Payment Item

580.000 Foot	Curb Removed and Reset	Linear
-----------------	------------------------	--------

CEMENT CONCRETE SIDEWALKS

GENERAL: This work shall consist of fine grading and compaction of gravel and/or crusher run and the furnishing and placing of cement concrete for sidewalks, driveways and aprons in accordance with these Specifications and/or as required by the OWNER. Depths of concrete shall be 4 inches (reinforced) in sidewalks and 6 inches (reinforced) in driveways, aprons, wheelchair ramps and roundings and as required by the OWNER.

MATERIALS: 7% ($\pm 1\frac{1}{2}\%$) air-entrained cement concrete (4,000 psi, 3/4" stone), borrow, and pre-formed joint fillers shall conform to the requirements of SECTION 701 of the "Standard Specifications for Highways and Bridges," Commonwealth of Massachusetts, Department of Public Works, 1988 Edition, including any addenda or amendments thereto, unless otherwise specified by the OWNER.

All concrete shall contain a fibrous concrete reinforcement of 100% virgin polypropylene fibrillated fibers of multi-design gradation as manufactured by Fibermesh, Synthetic Industries, 4019 Industry Drive, Chattanooga, Tennessee 37416 or an approved equal.

Wheelchair ramps shall include a prefabricated truncated dome modular system manufactured from high strength polymer concrete. Each accessible ramp shall have one panel 24 inches deep by 60 inches wide. **The color of the panels shall be gray.** The physical properties of the concrete panels shall meet the following requirements.

PROPERTY	VALUE
Water Absorption – ASTM D570	$\leq 0.35\%$
Slip Resistance – ASTM C1028	≥ 0.80
Abrasive Wear – ASTM D2486	BYK Gardner Tester $\leq 0.03/1,000$ cycles
Accelerated Weathering – ASTM G26	$\geq 2,000$ hours no fading
Chemical Stain Resistance – ASTM D543	no discoloration
Gardener Impact – ASTM D5420	≥ 450 in. lbf/in.
Compressive Strength – ASTM D695	$\geq 18,000$ psi

Tactile warning panels shall be installed in accordance with the manufacturer's recommendations and tamped into the fresh concrete and made flush with the surrounding surfaces. Concrete masonry blocks may be needed to insure continuous contact with the panel's underside with the concrete. Panels shall be protected from damage and concrete and asphalt spatter. Surfaces shall be cleaned as recommended by the manufacturer.

The concrete of the surrounding ramp shall be finished true and smooth to the required dimensions and slope before the tactile warning panel is installed. The panel shall be placed true and square to the curb line.

METHODS: Methods shall conform to the aforesaid, unless otherwise required by the OWNER. All transverse joints shall be formed with a 1/2" wide by 1" deep jointing tool such as the Marshall Town No. 836 jointing tool or the equivalent. All transverse joints shall be measured and divided equally and separately between the expansion joint distances. Continuous concrete blocks shall be no longer than 30 feet.

Concrete shall have a broom finish. A colored curing agent or retardant approved by the OWNER shall be applied to the finished concrete if requested by the OWNER. Otherwise, the curing method shall be as prescribed in Section 476.71A of the Mass. Standard Specifications.

The CONTRACTOR shall be responsible for the guarding of the wet concrete until it has sufficiently set up in place. The CONTRACTOR shall assume responsibility for replacing any concrete that is damaged due to cracking or vandalism. Replacement of concrete including saw cutting, removal and disposal of rejected concrete shall be done at the CONTRACTOR'S expense with no additional cost to the City. The CONTRACTOR maintains responsibility for the concrete for one year after the completion of the entire contract as noted in the Specifications of these documents (Section 6 Paragraph 8)

MEASUREMENT: Measurement for concrete sidewalks, drives and aprons shall be the number of square yards furnished, placed and accepted based on the OWNER'S field measurements or office calculations. Only cement concrete placed at the required depths and within the limits specified by the OWNER shall be accepted for payment.

PAYMENT: Payment for cement concrete sidewalks, drives and aprons shall be made for the number of square yards furnished, placed and accepted as determined above at the Contract unit prices for ITEMS 701.050 & 701.150 as set forth in the Bid. Said price and payment shall be full compensation for all fine-grading and compacting, for all necessary form work and materials including tactile warning strips and forming of tree wells for future plantings, for furnishing and placing of cement concrete and additives, including fibrous reinforcement and heating charges, for furnishing and applying all curing and/or retarding agents, and for furnishing all tools, equipment, labor, materials, and all else incidental thereto.

Payment Items

701.050	Cement Concrete Sidewalks (4" Fibrous Reinforced)	Square Yards
701.150	Cement Concrete Drives, Aprons and Ramps (6" Fibrous Reinforced)	Square Yards
702.000	Detectable Tile Surface for Handicap Ramps	Each

STONE BOUND REMOVED AND RESET

GENERAL: This work shall consist of resetting existing stone bounds to new lines and grades as required by the OWNER.

MATERIALS: Cement concrete for stone bounds shall be 3000 psi with ¾ inch stone.

METHODS: All excavation shall be done by hand. Prior to excavation at least three accurate ties shall be made to the stone bound, witnessed and approved by the OWNER. Points shall be in locations that will not be disturbed by other construction operations until the bound has been set.

After each stone bound has been set in place and backfilled, the CONTRACTOR will mark the exact survey point in the presence of the OWNER and drill a hole of approximately three-eighth inch diameter to a depth of approximately one-half inch deep.

If, as a result of negligence by the CONTRACTOR, ties are lost or deemed unreliable by the OWNER, it will be the responsibility of the CONTRACTOR to hire a Registered Professional Land Surveyor to conduct a survey to replace such points. The cost of the surveyor and all equipment, materials and manpower shall be paid by the CONTRACTOR at no additional cost to the City.

MEASUREMENT: Measurement for stone bound frame and cover shall be for the number of bounds reset as determined from actual count by the OWNER.

PAYMENT: Payment for stone bounds removed and reset shall be made for the number of stone bounds reset and accepted as determined above at the Contract unit price for ITEM 711.000 as set forth in the Bid. Said price and payment shall be full compensation for all materials including gravel and concrete, for all excavation, backfilling, tools, labor, and all else incidental thereto.

Payment Items

711.000	Stone Bound Removed and Reset	Each
---------	-------------------------------	------

STONE BOUND FRAME AND COVER

GENERAL: This work shall consist supplying and installing a cast iron cover over an existing stone bound where there is a change in grade as required by the OWNER.

MATERIALS: Cover shall be S208-6 as supplied by LeBaron Foundry Inc., Brockton, Massachusetts or an approved equal.

METHODS: All excavation shall be done by hand. Covers shall be installed on undisturbed earth with the cover set to the level of the finished grade.

If, as a result of negligence by the CONTRACTOR, the stone bound is moved or broken it shall be the responsibility of the CONTRACTOR to hire a Registered Professional Land Surveyor to conduct a survey to properly locate the stone bound point and the CONTRACTOR shall reset the bound to accurate line and grade. The cost of the replacement, including the surveyor and all equipment, materials and manpower shall be paid by the CONTRACTOR at no additional cost to the City.

MEASUREMENT AND PAYMENT: Measurement for stone bound frame and cover shall be for the number of stone bound frame and cover sets installed and accepted as determined from actual count by the OWNER. Payment for stone bound frame and cover shall be made for the number of stone bound frame and cover sets accepted by the OWNER as determined above at the Contract unit price for ITEM 711.100 as set forth in the Bid. Said price and payment shall be full compensation for all materials, for all excavation, backfilling, tools, labor, and all else incidental thereto.

Payment Items

711.100	Stone Bound Frame and Cover	Each
---------	-----------------------------	------

LOAM BORROW

GENERAL: This work shall consist of furnishing and placing loam borrow at the required depths and on approved areas in accordance with these Specifications, as indicated on the Contract Drawings, and/or as required by the OWNER. Only screened loam will be accepted for use.

All grass areas worked on or disturbed during construction and/or grassed areas shown on the Contract Drawings shall be graded to the necessary depths and covered with loam. The loam shall be fertile natural topsoil loam free from brush, weeds, stumps roots, stones over ½ inch in size, and any other objectionable matter. Respreading of existing on-site loam shall be part of ITEM 765.000 and will not be included with as part of this item.

METHOD: In sidewalk loam areas, loam shall be placed and uniformly spread on the sub-grade. When raked out and rolled, the depth of the loam shall be six inches. The finished surface shall be even with the top of the curb and the face of the sidewalk.

If loam is required in adjustment areas, it shall be placed at the depths indicated by the OWNER, but not to exceed 3 inches maximum depth.

MEASUREMENT: Measurement for loam borrow shall be for the number of cubic yards furnished and placed. Measurement shall be made after compaction. This amount shall be measured in the field by the OWNER or, at his option, determined from plan or office calculations. **This shall not include the respreading of any existing on-site loam.** 20% of the measured amount will be added to the final amount to allow for compaction.

PAYMENT: Payment for loam borrow shall be made for the number of cubic yards furnished and placed as determined above at the Contract unit price for ITEM 751.000 as set forth in the Bid. Said price and payment shall be full compensation for furnishing and placing loam borrow to the required depths and limits and for furnishing all tools, labor, equipment, materials, and all else incidental thereto. All work shall be done to the satisfaction of the OWNER. **There will be no separate payment for respreading of existing on-site loam. That shall be considered as part of ITEM 765.000 (SEEDING).**

Payment Items

751.000	Loam Borrow	Cubic Yards
765.000	Seeding	Square Yards
120.100	Unclassified Excavation	Cubic Yards

SEEDING

GENERAL: This work shall consist of the raking, fertilizing, liming, compacting and preparation of loam areas for the furnishing and application of seed. All work shall be done in accordance with these Specifications and/or as required by the OWNER. This item shall also include the resspreading of existing on-site loam obtained from stripping operations.

MATERIALS: Lawn seed shall be fresh, clean new crop seed. The seed shall be delivered to the work site with each container bearing the manufacturer's guaranteed analysis. Lawn seed shall be composed substantially as follows and shall be germinative and pure to at least the percentages indicated:

	Proportion	Germinative	Purity
Chewing Fescue or Creeping Red Fescue	25%	85%	97%
Alta Fescue	30%	85%	97%
Domestic Rye Grass	20%	90%	98%
Red Top	15%	90%	92%
White Clover or Alsike	10%	90%	98%

METHOD: The surface to receive seed shall be raked smooth, without pockets, and pleasing to the eye. The area shall be fertilized, limed, seeded, rolled and watered as required to promote satisfactory grass growth. Any areas or parts of areas that fail to show a satisfactory stand of grass within a reasonable amount of time for any reason shall be fertilized and re-seeded until all areas are covered with an adequate acceptable growth of grass. When the grass has grown, the CONTRACTOR shall, at the direction of the OWNER, make a minimum of at least one lawn cutting. Seeding shall be done only within certain times of the year as determined by the OWNER. If seeding is done in the fall season, the acceptance of the work shall not be until the end of the next following growing period. Seed shall be placed at a rate of 2 pounds per 1,000 square feet of area to be covered.

MEASUREMENT: Measurement shall be determined for the number of square yards of area treated and seeded as determined by the OWNER. This amount shall be measured in the field by the OWNER, or, at his option, determined from plan or office calculations.

PAYMENT: Payment for seed shall be made as determined above at the Contract unit price for ITEM 765.000 as set forth in the Bid. Said price and payment shall be full compensation for furnishing and placing all seed, for furnishing and spreading all fertilizer and lime, for raking and compaction of all areas affected, for all cutting, for all tools, labor, equipment, materials and all else incidental thereto. All work is subject to approval by the OWNER. There will be no payment for resspreading of existing on-site loam. This shall be considered as incidental to the work within this item.

Payment Items

765.000	Seeding	Square Yard
751.000	Loam Borrow	Cubic Yard

3" PVC ELECTRICAL CONDUIT

GENERAL: Furnish and install 3" PVC conduit in locations specified by the OWNER.

MATERIALS: PVC conduit shall be rigid polyvinyl chloride, Schedule 40 as manufactured by Carlon, Phillips Petroleum Co., Triangle Pipe and Tube Co., Inc., or approved equal. Fittings used with PVC conduit shall be PVC and of the same manufacturer as the conduit.

Warning tape shall be 6 inch wide, yellow polyethylene not less than 3.5 mils thick and shall be as manufactured by W. H. Brady Co., Seton Name Plate Co., Unitrust Corp., or approved equal. Warning tape shall display the following message:

**CAUTION CAUTION CAUTION
BURIED ELECTRIC LINE BELOW**

CONSTRUCTION METHODS: Prior to any road construction, the contractor shall check existing conduit in anticipation of installing wires for new cameras. If the contractor is unable to pull wires as required, he shall notify the OWNER who may authorize installation of new conduit.

Underground conduit shall run in straight lines. Where deviation from a straight line becomes necessary, bends shall be of sufficient radius for the proper rodding and installation of cable. Changes in direction of runs exceeding a total of 10 degrees, either vertical or horizontal, shall be made of long sweep bends having a minimum radius of curvature of 25 feet, except that manufactured bends may be used at ends of runs, and then only at or close to the end of the run. The long sweep bends may be made up of one or more curved or straight sections and/or combinations thereof. Manufactured bends shall have a minimum radius of 36 inches where a larger radius cannot be used.

Conduit bends shall be carefully made to prevent distortion of the circular cross-section. No conduit run shall have more than the equivalent of three 90 degree bends between pulling points. Changes in direction shall be made with bends, standards elbows and pull boxes.

The ends of all conduits shall be tightly plugged during construction until wires are to be pulled. Spare conduits shall be furnished with threaded caps, or removable, neoprene plugs.

Conduit shall be placed on a 6 inch bed of tamped sand.

Do not commence backfilling operations for trenches and structures until all conduit has been installed and approved, and the lengths and locations of all pipe and appurtenances have been recorded. Place an additional 6 inch bed of sand over conduit and backfill, tamping firmly in layers not exceeding six inches, compacting with hand rammers or mechanical tampers

A 2" x 6" untreated wooden plank shall be installed three inches above the conduit. Warning tape shall be installed twelve inches above the plank.

MEASUREMENT AND PAYMENT: Conduit shall be measured in the field prior to backfilling operations. Failure to allow ample time for the Engineer to make the required measurements will forfeit the Contractor's right-of-claim to any length of conduit other than that allowed by the Engineer. Payment

for PVC conduit shall be made for the number of linear feet of conduit installed as determined above at the contract unit price for item 801.300 as set forth in the Bid. Payment shall be full compensation for excavation and backfill; furnishing of tools; hardware; labor; materials including concrete, sand cover and warning tape; equipment; and all else incidental thereto.

Payment Item

801.300

3" PVC Electrical Conduit

Linear Feet

LOOP DETECTORS AND LEAD-IN WIRES

GENERAL: This work shall consist of furnishing and installing loop detectors and lead-in wires in areas of resurfacing where the existing loops and lead-ins are removed due to excavation operations. The work shall be done by the CONTRACTOR to the satisfaction of the OWNER.

MATERIALS AND METHODS: The CONTRACTOR shall obtain an electrical permit from the City of Waltham Wire Inspector prior to construction. The CONTRACTOR shall notify the City of Waltham Wire Inspector 60 day's prior to start of work. All traffic signal equipment and related items (such as pavement markings and signs) shall be in place and permission obtained from the City of Waltham Wire Inspector prior to the traffic signal being turned on stop and go operation.

Before starting any installation work, the electrical CONTRACTOR shall furnish data sheets and shop drawings on the materials and methods to be used.

In advance of the loop detector installation, the CONTRACTOR shall mark, on site, the loop detectors with any changes required by field conditions such as manholes. The loop detector layout shall be inspected and approved by the OWNER before the loop detectors are installed.

Loop wire shall be encased in a protected plastic tubing of PVC or polyethylene plastic, IMSA 51-5,0.25 inch outside diameter, and the wire may have cross-linked polyethylene insulation or it may have THHN/THWN insulation.

Splicing insulator shall be an approved re-enterable rigid body splice kit with a non-hardening sealing compound compatible with the wire insulation.

Splice and Connection: Splicing and connection shall be made in the pull box nearest the roadway loop sensor but not exceeding four loops per pull box. All loops included in a detector group as shown on the plans shall be spliced in a single pull box. Each lead and lead-in connector shall be stripped back and spliced using a pressure type wire connector applied with a crimping tool. Multiple loop sensors shall be identified as detailed on the plans.

Lead-in splicing shall be staggered to prevent contact with each other. Each crimped splice shall be soldered and insulated. The insulation material shall be heat-shrunked polyolefin. The shielded lead-in cable outer jacket and shield shall be stripped back sufficiently to ensure that the shield cannot come into contact with the spliced conductors. Follow the instructions of the kit manufacturer for this procedure when installing the re-enterable splice kit.

NOTE WELL: The above splice shall be done on the day of the loop wire installation to prevent the entrance of any moisture into the plastic tubing.

The lead-in conductors shall be connected to the appropriate terminals in the controller cabinet, by using crimped or soldered terminal ends. The heat source for soldering shall be electrical not exceeding 30W capacity.

Testing of Loops: The following test procedure shall be performed in the presence of the OWNER before and after the loop sensor is sealed in the pavement as detailed below. The cost of equipment, labor, and

materials to perform such testing and similar re-testing following repairs, replacement, or adjustment of any detector within the project area shall be included in the contract unit price for this Item.

After installation of wire loop sensors in the roadway and installation of shielded lead-in connecting the loop sensors to the controller cabinet each loop sensor and lead-in combination shall be tested (at the controller cabinet) for proper installation. The resistance from lead to lead of the same loop shall not exceed three ohms per one thousand feet as measured by a high quality meter suitable for measurements of low resistance in the range of 1 to 6 ohms.

A megohm meter test at 500 volts DC shall be made between the two leads of a loop/lead-in combination temporarily spliced together, but otherwise disconnected from all terminals, and the shield drain wire and the earth ground connection. These resistances shall be at least one hundred megohms.

A megohm meter test at 500 volts DC shall be made between lead-in shield and the earth ground rod. This resistance shall be at least one hundred megohms.

The meter used for these tests shall be checked for calibration each day of use by using a resistor block of plus or minus 5% resistors simulating loads of 1 megohm, 20 megohm and 100 megohms. The observed meter reading shall be plus or minus 10% of the nominal resistor load.

If any loop sensor and lead-in combination fails to pass any one of the four tests, it shall be repaired and then re-tested on two occasions at least two weeks apart and then shall pass on each re-test occasion. If the loop sensor lead-in combination does not pass all these re-tests, a new loop sensor and/or lead-in shall be installed, and shall pass these tests, at no additional cost.

After the above tests have been satisfactorily completed, all loop sensor/shielded lead-in inductance shall be measured and a written report of the results shall be filed with the OWNER and a copy stored with the "box prints" at the intersection.

MEASUREMENT AND PAYMENT: Measurement for loops furnished, installed and accepted by the OWNER shall be the nominal length of the loop detector and lead-in, not the length of wires. Payment for loop detectors and lead-in wires shall be made as determined above at the contract unit price for ITEM 819.837 as set forth in the Bid. Said price and payment shall be full compensation for furnishing and installing all detectors and lead-ins, all associated materials required, all testing of detectors after installation, and all else incidental thereto to complete the work within this item. All work shall be done to the satisfaction and the approval of the OWNER.

Payment Item

819.837	Loop Detectors with Lead-In Wires	Linear Foot
801.300	3" PVC Electrical Conduit	Linear Feet

TRAFFIC CAMERA

GENERAL: This work shall consist of furnishing and installing traffic cameras on mast arms or traffic light poles in locations specified by the OWNER.

The CONTRACTOR shall obtain an electrical permit from the City of Waltham Wires Inspector prior to construction. The CONTRACTOR shall notify the City of Waltham Wires Inspector 60 days prior to start of work.

EQUIPMENT: The CMOS Presence Sensor shall be an all-in-one CMOS camera presence sensor. A COD camera shall not be allowed.

The CMOS camera and detection processor shall be contained within a single compact housing. It shall be housed in a discreet and esthetical enclosure of polycarbonate and fiber reinforced polyamide with integrated sunshield/rain visor. The unit dimensions (without mounting bracket) shall be round and no larger than 4' in diameter for minimal EPA impact on existing structures.

The unit shall weigh no more than 22 ounces (including mounting bracket, excluding cabling) for minimal loading impact on existing structures.

The power supply shall accept 12 to 26V AC or DC and the power consumption shall be less than 1.5W. It shall transmit the presence detection information to the traffic controller via four optically isolated open collector outputs. It shall have an RS485 interface for setup.

The unit shall come with a mounting bracket and 4 foot pig tail cable with a military style connector at the end. The unit shall have two available lenses; a 3.5 mm wide angle lens for a detection range of 0 to 80 feet and an 8 mm narrow angle lens for a detection range of 20 to 250 feet.

The unit shall be capable of mounting on mast arms, strain poles or on the tops of pedestal pole mounted signals. The unit shall have an ingress protection rating of IP67. The unit shall operate at a temperature range between -34°C and +80°C.

The unit shall be compliant with CE directive 89/336/EEC; product standard EN55022 class A and EN 50082-2 for Electromagnetic Compatibility (EMC); FCC: FCC part 15 class A; Shock & vibration NEMA II specs.

MEASUREMENT AND PAYMENT: Payment for the traffic camera related equipment will be made at the unit price for ITEM 819.840 as set forth in the Bid. Said price shall be full compensation for furnishing, installation and testing of all equipment, including all labor, tools and materials; for all mounting brackets, connectors and miscellaneous hardware and all else incidental to the satisfactory completion of the work within this item.

Payment Items:

819.840	Traffic Camera	Each
801.300	3" PVC Electrical Conduit	Linear Feet
819.850	Traffic Camera Related Equipment	Each
819.860	Sensor Cable	Linear Foot

TRAFFIC CAMERA RELATED EQUIPMENT

GENERAL: This work shall consist of furnishing and installing traffic camera related equipment in locations specified by the OWNER. This item shall include all related equipment need to make the traffic cameras fully operational.

The CONTRACTOR shall obtain an electrical permit from the City of Waltham Wires Inspector prior to construction. The CONTRACTOR shall notify the City of Waltham Wires Inspector 60 days prior to start of work.

EQUIPMENT:

One Sensor Firmware& Software

Sensor firmware & software shall provide presence detection for up to 8 zones. It shall provide video images for the exact positioning of the detection zones. It shall be simple to program via a laptop or ultra-portable PC. It shall provide both non-directional and directional detection in up to 4 directions, user-configured for each zone.

The sensor firmware shall be capable of being upgraded via the PC software. The PC software shall allow for setup of the unit, zone configuration, output assignment, detection verification via refreshing JPEG images (1 detection zone or complete camera image) and the download/upload of configuration data.

The PC software shall run on Windows XP Professional (SP1 and SP2), Windows XP Home, Windows 2000 Professional (SP3), Windows 98(1st and 2nd Editions), Windows NT 4.0 (SP6a) and Windows ME. The software shall require the Java Runtime Environment Version 1.4.0 or higher and this shall be packaged with the software bundle.

One Quadruple Sensor Controller Interface Module

The controller interface module (CIM) shall be no larger than 3.5”H x 7.5W x 2.5”D and weigh no more than 9oz. The CIM shall be DIN rail mountable. The CIM shall be able to interface to up to 4 CMOS presence sensors. One shall be required for up to 4 sensors. The CIM shall have sixteen green LED detection output indicators. The CIM shall provide optical isolation. The CIM shall have integral terminal blocks for power input, power output (to sensor) RS486 (from sensor), 16 detection outputs + common (to controller), one general error output + reference (to controller) and Shielding/Earth Ground.

The CIM shall have a USB port for the USB interface. The CIM housing shall be plastic. EMC: CE directive 891336/EEC; product standard EN55022 class A. FCC: FCC part 15 class A. Shock & vibration NEMA II specifications.

One Cabinet Mount Detector Interface

Where applicable, a shelf mount detector interface shall be installed in the cabinet. This interface shall allow the use of the existing shelf mount loop detector harness to facilitate communications from the CIM to the traffic controller. It shall have and military style connectors to match that of the shelf mount detector harness.

One Sensor Mounting Hardware

The mounting bracket shall be made from fiber reinforced polyamide. The mounting bracket shall be capable of being banded to a horizontal or vertical pole. The mounting bracket shall provide for at least 2 axes of rotational adjustment: pan and tilt.

One Ultra-Portable PC Configuration

Ultra-Portable Tablet PC with 512MB RAM, 40GB Hard drive. Windows XP Tablet Edition. 7" WVGA Widescreen Active Matrix TFT LCD Touch Screen or approved equal.

MEASUREMENT AND PAYMENT: Payment for the traffic camera related equipment will be made at the contract unit price for ITEM 819.850 as set forth in the Bid. Said price shall be full compensation for furnishing, installation and testing of all equipment, including all labor, tools and materials; for all mounting brackets and miscellaneous hardware and all else incidental to the satisfactory completion of the work within this item.

Payment Items:

819.850	Traffic Camera Related Equipment	Each
801.300	3" PVC Electrical Conduit	Linear Feet
819.840	Traffic Camera	Each
819.860	Sensor Cable	Linear Foot

SENSOR CABLE

GENERAL: This work shall consist of furnishing and installing traffic camera sensor cable in locations specified by the OWNER.

The CONTRACTOR shall obtain an electrical permit from the City of Waltham Wires Inspector prior to construction. The CONTRACTOR shall notify the City of Waltham Wires Inspector 60 days prior to start of work.

EQUIPMENT: The sensor cable shall be housed within a single overall jacket. The sensor cable shall consist of two 22AVVG twisted pairs: one 22AWG twisted pair for RS485 communications and one 22AWG twisted pair for power (i.e. in total 4 wires plus shielding). The 22AWG twisted pairs shall be 7 stranded tinned copper and overall shielding. The 22AWG paired color coding shall be Green/Yellow for RS485 and Blue/Red for power. The 22AWG twisted pair shield shall be an alum poly foil with 100% coverage and the drain wire shall be 24AWG 7 strand tinned copper. The insulation thickness shall be 0.010". The cable shall be rated for 300V and -20 to 90 Degrees Celsius. The overall jacket shall be a 0.032" black PE with a nominal diameter of 0.25". There shall be a 4 foot pig tail at the CMOS camera with a military style connector on the opposite end of the CMOS camera. This MS connector shall be weatherproof.

MEASUREMENT AND PAYMENT: Payment for Sensor Cable will be made at the contract unit price for ITEM 819.860 as set forth in the Bid. Said price shall be full compensation for furnishing, installation and testing of all equipment, including all labor, tools and materials; miscellaneous hardware and all else incidental to the satisfactory completion of the work within this item.

Payment Items:

819.860	Sensor Cable	Linear Foot
801.300	3" PVC Electrical Conduit	Linear Foot
819.840	Traffic Camera	Each
819.850	Traffic Camera Related Equipment	Each

SAFETY SIGNING
FOR CONSTRUCTION OPERATIONS

GENERAL: This work shall consist of furnishing, installing, maintaining, repositioning, removing and storing temporary signs for the protection of the traveling public and working personnel during construction and maintenance operations. The design, application and installation of such signs shall comply with the Massachusetts Manual on Uniform Traffic Control Devices, latest edition. All materials provided by the CONTRACTOR under this item shall remain the property of the CONTRACTOR upon completion of this project.

MATERIALS AND METHODS: Materials required under this section need not be new but must be in excellent condition. Any materials that in the judgment of the OWNER are unsatisfactory in appearance or performance shall be removed and immediately replaced by acceptable units at no additional cost to the City. Signs that are missing shall be immediately replaced by the CONTRACTOR at no additional cost to the City. Signs that are not consistent with the use of the roadway shall be removed or covered. All work shall be done by the CONTRACTOR and to the satisfaction of the OWNER.

Materials shall conform to Sections 828 and 840 of the Commonwealth of Massachusetts Standard Specifications except the plywood material shall conform to the following: Plywood sign panels shall be fabricated from five-ply 5/8" thick Medium Density Overlaid Exterior Type, A-B both sides surface in natural color and the whole conforming with the requirements and tests for the above as set forth in U. S. product Standard PS1-74 for Construction and Industrial Plywood. Plywood shall bear the grade trade mark of an approved testing agency. The entire sign face shall be reflectorized with reflective sheeting conforming to M9.30.0, type III of the Commonwealth of Massachusetts Standard Specifications.

Background sheeting shall be fluorescent orange. The maximum spectral radiance factor, in accordance with Section 5.1 of ASTM E991 for the fluorescence shall be 110% minimum for new signs and 60% minimum for weathered signs. Actual size and legend shall be determined by the OWNER.

MEASUREMENT: Measurement for safety signing shall be based on the square foot surface area of the signs. All measurements for safety signing shall be made in the field by the OWNER. Sign supports for safety signing are considered incidental to installation of the signs and there shall be no additional payment.

PAYMENT: Payment for Safety Signing for Construction Operations shall be made based on the square foot area as determined above at the Contract unit price for ITEM 850.221 as set forth in the Bid. Said price and payment shall be full compensation for furnishing, maintaining, repositioning, removing and storing signs, including all labor, equipment, tools, cement concrete, if required, and all else incidental to the satisfactory completion of the work within this item. All work is subject to approval by the OWNER.

Payment Items

850.221	Safety Signing for Construction Operations	Square Foot
---------	--	-------------

4" TEMPORARY PAINTED LINE

GENERAL: This work shall including temporary paint for traffic control following cold planing in locations required by the OWNER. The work to be done under these items shall conform to the relevant provisions of Section 860 of the 1988 MDPW Standard Specifications for Highways and Bridges, and the following:

METHODS: The layout shall be approved by the OWNER. Application shall be sufficient to last until the wearing course of pavement has been applied.

MEASUREMENT: Measurement for temporary painted lines shall be for the actual number of linear feet furnished and installed by the CONTRACTOR and accepted by the OWNER.

PAYMENT: Payment for temporary painted lines shall be for the actual linear feet as determined above at the contract unit price for ITEM 854.014 as set forth in the Bid. Said price and payment shall be full compensation for furnishing and placing of all materials, all tools, labor, equipment and all else incidental to the completion of the work. All work is subject to final approval and acceptance by the OWNER.

Payment Items

854.014	4" Temporary Painted Line	Linear Foot
---------	---------------------------	-------------

PAVEMENT ARROWS AND LEGENDS

REFLECTORIZED THERMOPLASTIC

GENERAL: The work to be done under these items shall conform to the relevant provisions of Section 860 of the 1988 MDPW Standard Specifications for Highways and Bridges, and the following:

METHODS: The layout of all necessary field controls by the CONTRACTOR of the several types of traffic line systems shall be approved by the OWNER. The width and spacing of stop lines and crosswalks shall be as indicated on the plans.

MEASUREMENT: Measurement for pavement arrows, legends, crosswalks, stop lines, chevrons and/or gore lines shall be for the actual square foot of area of material furnished and installed by the CONTRACTOR and accepted by the OWNER. Measurement for other thermoplastic lines shall be for the actual linear foot of material furnished and installed by the CONTRACTOR and accepted by the OWNER. All measurement shall be done in the field by the OWNER.

PAYMENT: Payment for arrows, legends, crosswalks, stop lines, chevrons and/or gore lines shall be for the actual square foot area as determined above at the contract unit prices for ITEMS 864.040 and 865.100 as set forth in the Bid. Payment for other thermoplastic markings shall be for the actual linear foot measurement as determined above at the contract unit prices for ITEMS 868.040 and 868.020 as set forth in the Bid. Said price and payment shall be full compensation for furnishing and placing of all materials, all tools, labor, equipment and all else incidental to the completion of the work within these items. All work is subject to final approval and acceptance by the OWNER.

Payment Items

864.040	Pavement Arrows and Legends ReflectORIZED Thermoplastic	Square Foot
865.100	X - Walks and Stop Lines ReflectORIZED White (Thermoplastic)	Square Foot
868.040	4" ReflectORIZED Thermoplastic Line	Linear Foot

PORTABLE MESSAGE BOARD

GENERAL: Portable message boards shall conform to the relevant provisions of Section 6F.52 of the Federal Highway Administration Manual on Uniform Traffic Devices. Message boards shall be solar powered, capable for displaying three alternating messages of three lines, eight characters per line.

MEASUREMENT AND PAYMENT: Measurement for each Portable Message Board shall be per day whenever boards are required and accepted by the OWNER. Payment for Portable Message Boards shall be as determined above at the contract unit prices for ITEM 870.000 as set forth in the Bid. Said price and payment shall be full compensation for furnishing equipment and programming, locating and relocating message boards as required by the OWNER. All work is subject to final approval and acceptance by the OWNER.

Payment Items

870.000	Portable Message Board	DAY
---------	------------------------	-----

TRAFFIC POLICE

GENERAL: The CONTRACTOR shall provide such uniformed police officers (outside their regular tour of duty) as the OWNER shall deem necessary to avoid, so far as reasonably possible, damage to the safety of persons and substantial interference with the free circulation of traffic. When so required by the OWNER, the CONTRACTOR shall make all arrangements in obtaining police assistance. The CONTRACTOR shall pay the amount due for such assistance to the City of Waltham. The CONTRACTOR shall then be reimbursed by the City of Waltham. Police details may be arranged by calling (781) 314-3604.

All bills for police details must be paid in full by the CONTRACTOR before reimbursement is made by the City of Waltham. Only bills stamped "PAID" by the City Treasurer's Office will be accepted by the OWNER.

METHOD OF PAYMENT: The CONTRACTOR shall pay to any police officer employed by him the prevailing rate of wage to special duty police officers (MGL Chapter 149, §34B). The quantity on the Bid form for ITEM 999.001 is an estimate for funding and bid comparison purposes. Payment to the CONTRACTOR for special duty police will be made at the rate established by the Waltham Police Department.

Payment shall be made by the CONTRACTOR within 30 days of billing. Failure to pay an outstanding bill within 30 days may result in a penalty charge to the CONTRACTOR for late payment. There will be no reimbursement for any penalties or late charges that may be assessed against the CONTRACTOR for late payment. Furthermore, the OWNER will accept no further requests for payment if police detail bills are more than 30 days in arrears.

The CONTRACTOR will not be reimbursed for any detail that he fails to cancel when it is not required (work does not proceed as scheduled or due to inclement weather, etc.) Reimbursement will be entered in the next estimate for payment.

Reimbursement shall be made on all bills stamped "PAID" by the City of Waltham Treasurer's Office and presented to the OWNER less any amount for unnecessary details not canceled by the CONTRACTOR when required.

It is suggested that payments be made in person at the Treasurer's Office and that a copy of the bill be presented to the Treasurer's Office at the same time so that it may be stamped "PAID" and presented to the OWNER by the CONTRACTOR.

PAYMENT: Payment for special duty police will be made on a dollar for dollar basis as determined above for ITEM 999.001 as set forth in the Bid. Said price and payment shall be full compensation for furnishing all special duty police.

Payment Item

999.001

Traffic Police

Per Dollar

8 - MISCELLANEOUS DETAIL DRAWINGS
AND DOCUMENTS
FOR
ANNUAL CONTRACT FOR
RESURFACING OF BITUMINOUS ROADWAYS AND REPAIRS TO SIDEWALKS

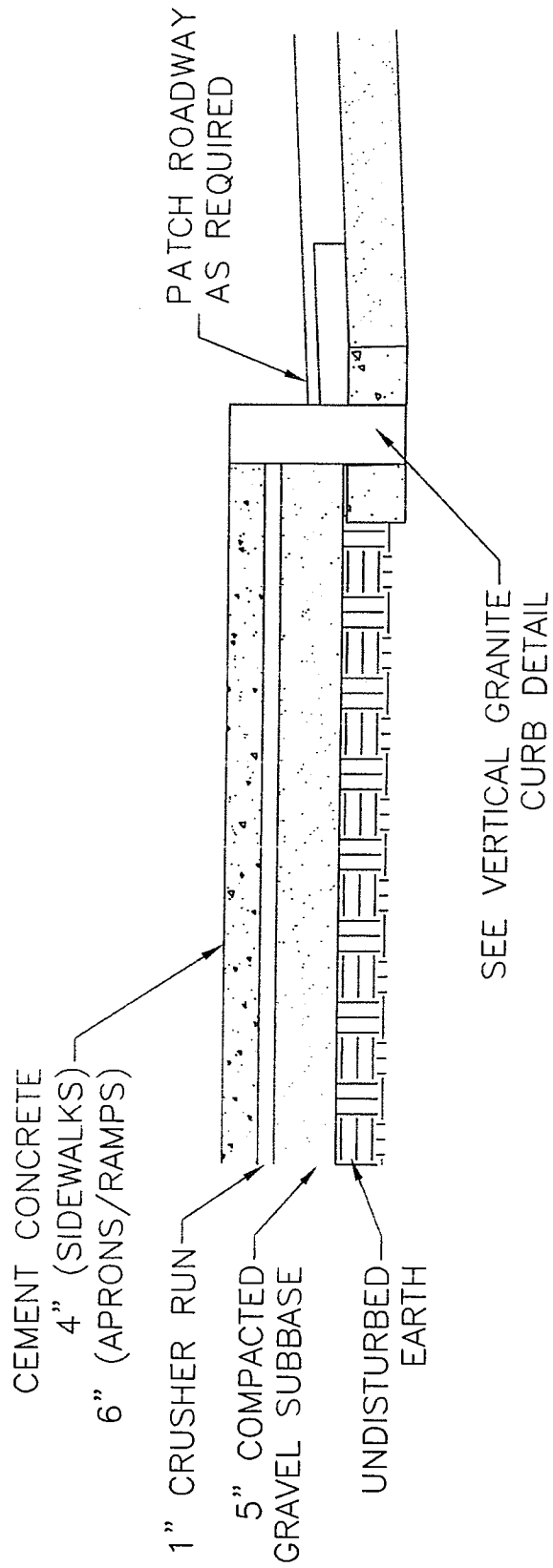

SIDEWALK CROSS-SECTION

FIGURE NAME:

4" / 6" CEMENT CONCRETE SIDEWALK

SCALE:

NOT TO SCALE

CITY OF WALTHAM, MA. - ENGINEERING DEPARTMENT
STANDARD DETAILS

REV. DATE:

3/30/2011



HEAVY DUTY GATE BOX
COVER MARKED "WATER"
SEE NOTE 1.

GATE BOX LOCATED IN ROADWAY

1 1/2" BINDER AND 1 1/2" TOP
PROPERLY COMPACTED

6" CEMENT CONCRETE
ALLOW 3" FOR SURFACE MATERIAL

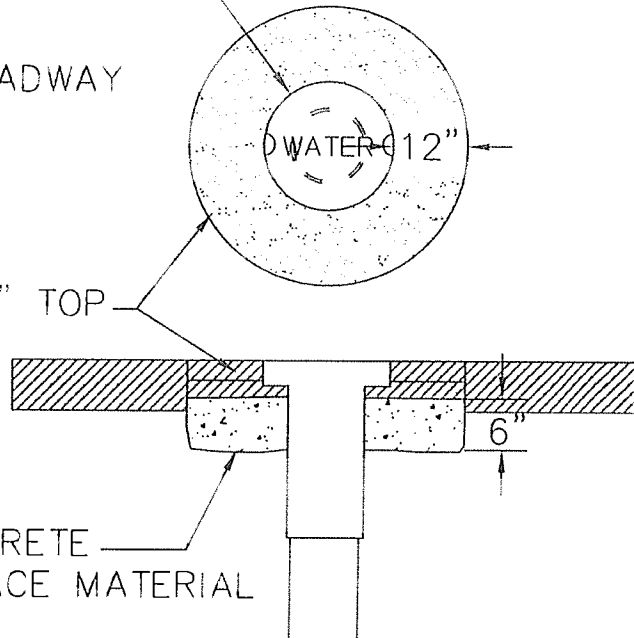

NOTES:

1. VALVE BOX COVER SHALL BE EJ PRESCOTT
PRODUCT NO.45005 600 OR APPROVED EQUAL.
2. VALVE BOX SHALL BE TWO-PIECE, CAST IRON
SLIDING TYPE, WITH TOP FLANGE VALVE BOX
AND BELL SECTION BASE.

GATE BOX COLLAR DETAIL

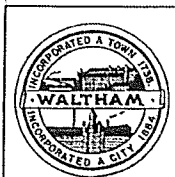

FIGURE NAME:

WATER GATE BOX COLLAR DETAIL

SCALE:

NOT TO SCALE

CITY OF WALTHAM, MA. – ENGINEERING DEPARTMENT
STANDARD DETAILS

REV. DATE:

3/30/2011

85

108

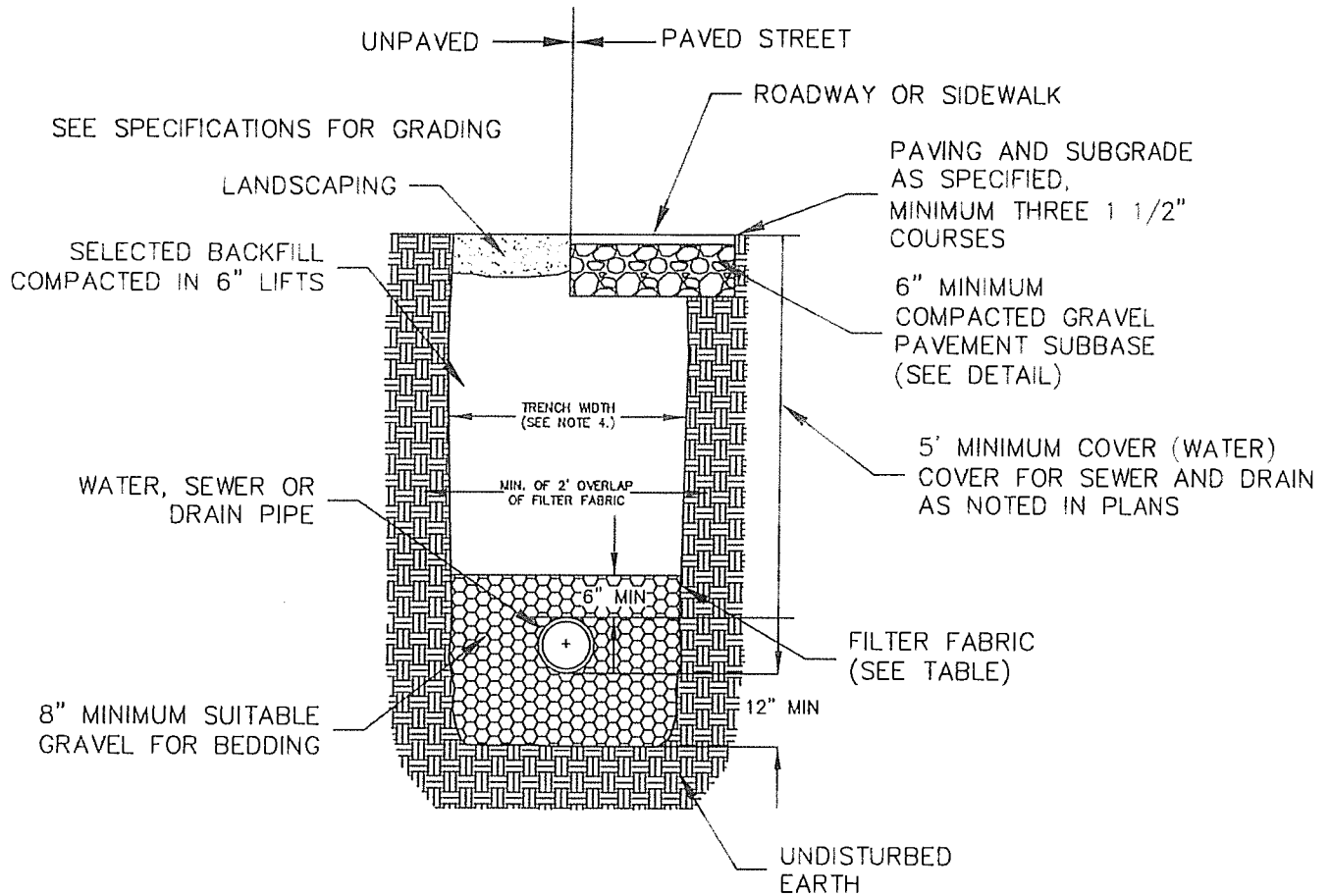

NOTES:

1. ALL TRENCHES MUST BE JETTED OR PUDDLED AS REQUIRED BY THE ENGINEER.
2. PRIOR TO FINISHING PAVING, CUT SQUARE EDGES AT EXISTING PAVEMENT, AT LEAST 6 INCHES BEYOND OUTERMOST DISTURBED PAVEMENT.
3. NO LEDGE TO BE WITHIN 6" OF PIPE.
4. TRENCH WIDTH:

LEDGE: OUTSIDE DIAMETER OF PIPE PLUS 2 FEET

EARTH: GREATER OF LEDGE VALUE OR 3 FEET (OR AS DETERMINED BY THE ENGINEER)

FILTER FABRIC USE

	SOIL TYPE	
	SILT OR CLAY	GRANULAR SOIL
ABOVE GROUND WATER	FILTER FABRIC NOT REQUIRED	FILTER FABRIC NOT REQUIRED
BELOW GROUND WATER	FILTER FABRIC REQUIRED	FILTER FABRIC NOT REQUIRED

WATER, SEWER, AND DRAIN TRENCH DETAIL

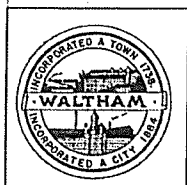

FIGURE NAME: TRENCH DETAIL

CITY OF WALTHAM, MA. — ENGINEERING DEPARTMENT

STANDARD DETAILS

SCALE: NOT TO SCALE

REV. DATE: 3/30/2011

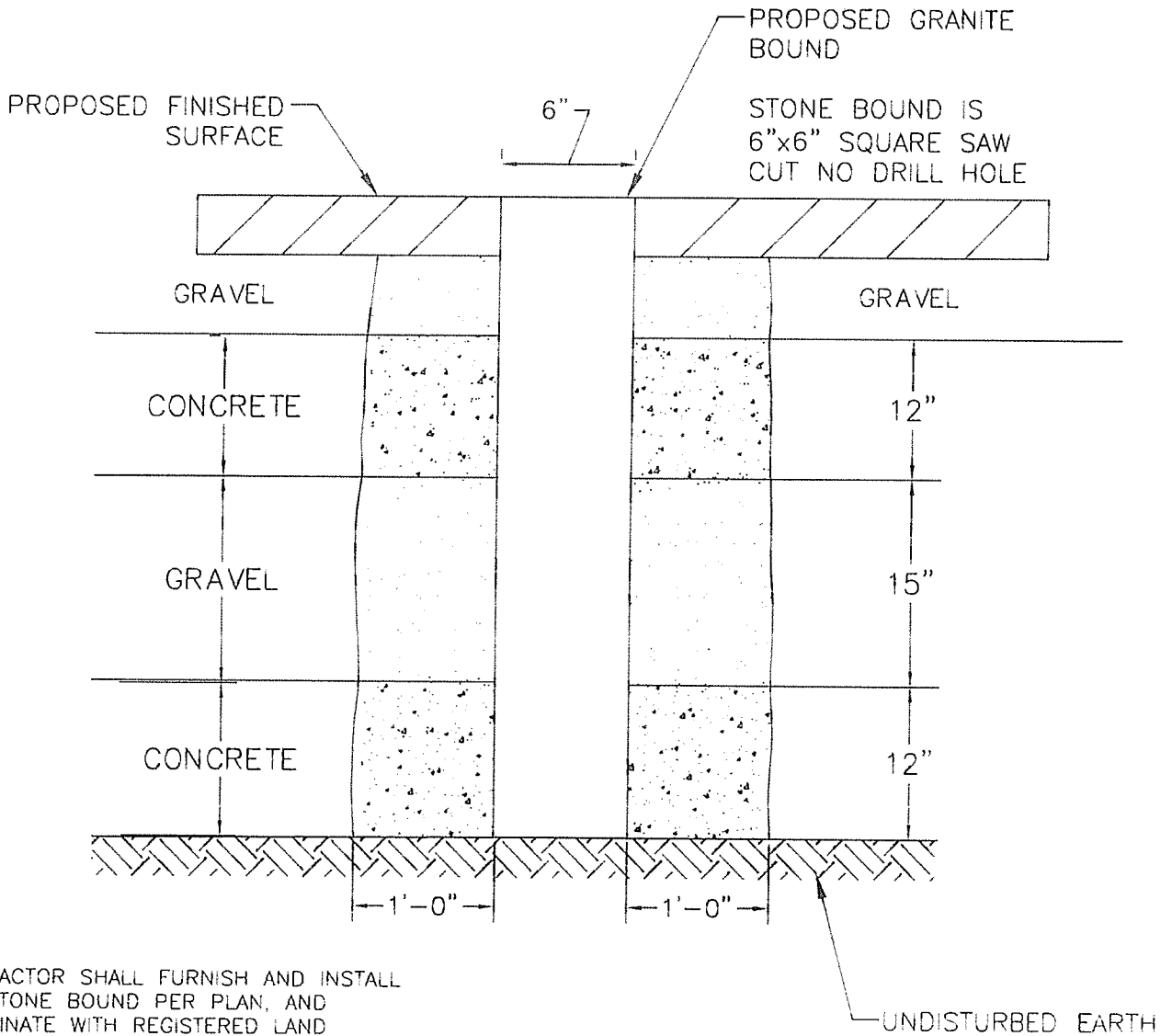

NOTES:

1. CONTRACTOR SHALL FURNISH AND INSTALL NEW STONE BOUND PER PLAN, AND COORDINATE WITH REGISTERED LAND SURVEYOR FOR EACH LOCATION.
2. DRILL HOLES SHALL BE SET BY REGISTERED PROFESSIONAL LAND SURVEYOR.

STONE BOUND DETAIL

	<p>FIGURE NAME:</p> <p style="text-align: center;">STONE BOUND DETAIL</p>	<p>SCALE:</p> <p style="text-align: center;">NOT TO SCALE</p>
	<p style="text-align: center;">CITY OF WALTHAM, MA. – ENGINEERING DEPARTMENT</p> <p style="text-align: center;">STANDARD DETAILS</p>	<p>REV. DATE:</p> <p style="text-align: center;">3/30/2011</p>

24" MANHOLE COVER WITH 32" FLANGE

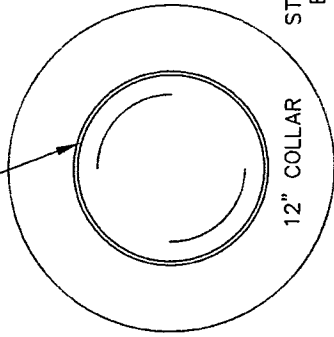

STANDARD FRAME/RING COVER
EAST JORDAN IRON WORKS
MANHOLE FRAME: 00124611
DRAIN FRAME & COVER: 00124826C02
SEWER FRAME & COVER: 00124825C02

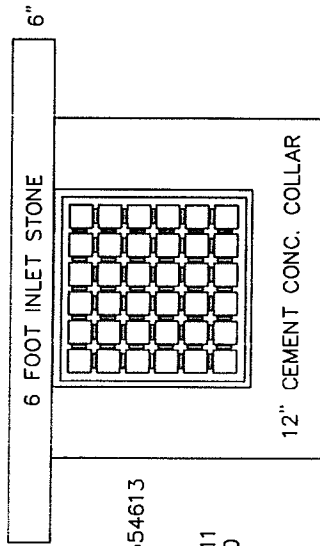

EAST JORDAN IRON WORKS 00554613
3-FLANGE FOR CURBING
INSTALLATION
ALTERNATE GRATE: 00554611
CASCADE GRATE: 00552050

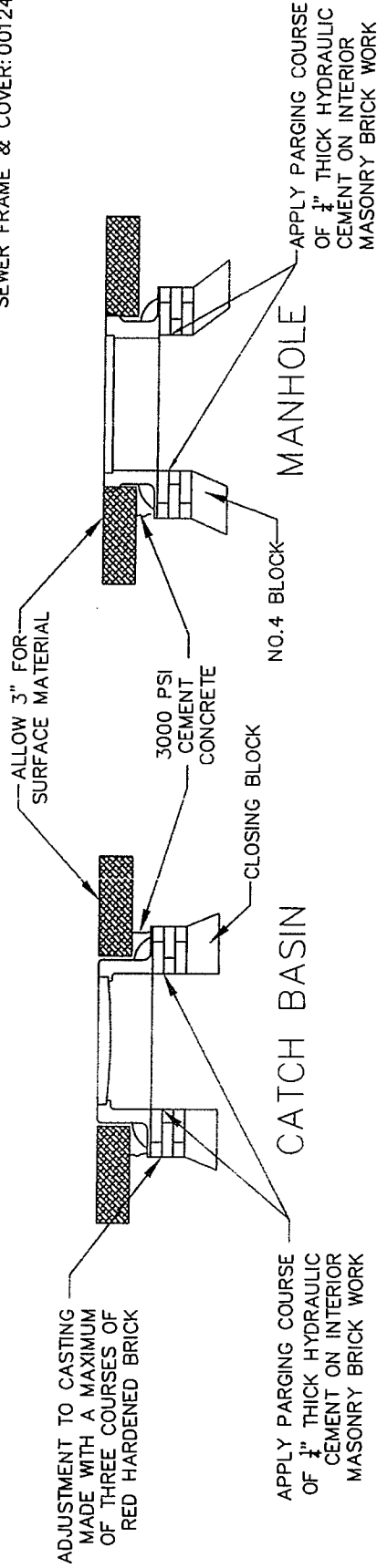

CEMENT CONCRETE COLLARS
FOR MANHOLES AND CATCH BASINS

FIGURE NAME:

FRAMES, GRATES & CONCRETE COLLARS DETAIL

SCALE:

NOT TO SCALE

CITY OF WALTHAM, MA. - ENGINEERING DEPARTMENT
STANDARD DETAILS

REV. DATE:

3/30/2011



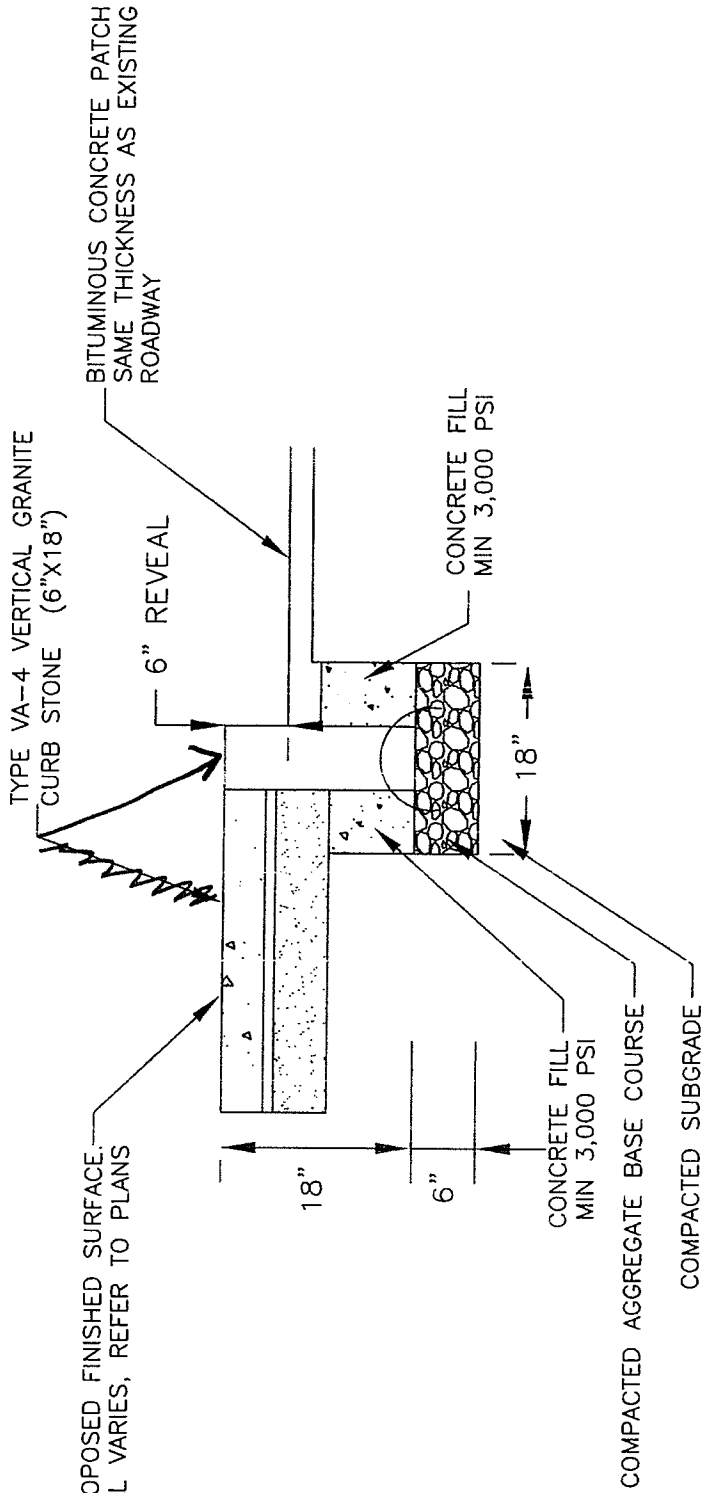

TYPICAL VERTICAL GRANITE CURB DETAIL

FIGURE NAME:

TYPICAL VERTICAL GRANITE CURB DETAIL

SCALE:

NOT TO SCALE

CITY OF WALTHAM, MA. - ENGINEERING DEPARTMENT
STANDARD DETAILS

REV. DATE:

3/30/2011

