

The City of Waltham

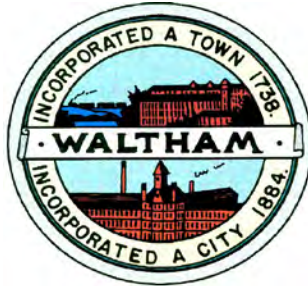

**Invites
Interested Parties
To propose the best offer and or bid
For the service or product herewith described:**

Kenmore Terrace Sewer Main Replacement Project

The GENERAL BID is due: 10.00 AM Monday December 14, 2020
(Virtual/Zoom Opening)

VIRTUAL PRE-BID Meeting: 10.00 AM Thursday December 3, 2020
(Meet at the corner of Kenmore Road and Kenmore Terrace)

LAST DAY FOR WRITTEN QUESTIONS: 12 Noon Friday December 4, 2020
(To jpedulla@city.waltham.ma.us)

TABLE OF CONTENTS

Kenmore Terrace Sewer Main Replacement Project

<u>SECTION NO.</u>	<u>TITLE</u>
	Cover
	Table of Contents
DIVISION 0	
00010	Invitation to Bid
00100	Instructions to Bidders
00200	Compliance
00300	Bid Documents
00440	COVID Bid Opening Process
00450	COVID Bid Delivery
00500	Agreement – Additional Contract Documents
00501	Performance Bond
00502	Payment Bond
00540	Liquid Asphalt Price Adjustments
00710	Prevailing Wages
00821	Permits
 <u>TECHNICAL SPECIFICATIONS/ ATTACHMENTS</u>	
A	Special Provisions
B	Drawings
C	Record Plans
D	Service Tie Cards

DIVISION 0

SECTION 00010
INVITATION TO BID

Kenmore Terrace Sewer Main Replacement Project

Location of Work: City of Waltham Massachusetts. Sealed Bids for construction of **the Kenmore Terrace Sewer Main Replacement Project** will be received by Joseph Pedulla, CPO, Purchasing Department 610 Main Street Waltham, Massachusetts until **10:00 a.m., December 14, 2020** at which time and place all bids will be publicly opened and bids read aloud. Bids submitted after this time will not be accepted. The project involves the following major items:

1. Furnishing and installing new sanitary sewer pipes including the following components:
 - a. Gravity sanitary sewers
 - b. Sewer and water service laterals
 - c. Sewer manholes
 - d. Removal and disposal or abandonment of existing sewer manholes, sewers and laterals
 - e. Disposal of demolition and excess materials
 - f. Trench dewatering
 - g. Excavation and backfill
 - h. Appurtenant work
2. Locating and replacing certain sanitary sewer services.
3. Testing of sanitary sewer pipes and manholes for proper installation and performance.
4. Locating and replacing certain water services.
5. Testing and disinfecting water services for proper installation and performance.
6. Site restoration work including curbing and landscaping.
7. Pavement restoration work including **daily temporary paving**; and full-width mill and overlay. Refer to Table 5 for the roadway restoration per street.
8. Other miscellaneous work shown in the Specifications for a complete and operational system.

Contract Documents may be obtained by visiting the City's web site at www.city.waltham.ma.us/bids after 4 pm November 18, 2020.

BID SECURITIES shall be in amount of 5% of the bid and in the form of a certified check drawn upon a bank within the State of Massachusetts or a bid bond executed by a surety company authorized to do business in Massachusetts, made payable to the **CITY OF WALTHAM**.

The successful bidder must furnish a 100% **PERFORMANCE** and 100% **PAYMENT BOND** and will be required to execute the Contract Agreement within five (5) days following notification of the acceptance of his Bid. The **CITY OF WALTHAM** reserves the right to reject any or all bids, to accept any bid, to waive any informality on bids received, and to omit any item or items deemed advisable for the best interests of the **CITY OF WALTHAM**. The award of the contract may be contingent upon the appropriation of funds from City Council Meeting. All costs associated with the preparation of the bids shall be the responsibility of the bidder, regardless of whether or not the Contract is award.

END OF SECTION

SECTION 00 10 00 - INSTRUCTION TO BIDDERS

PART 1 - GENERAL

1.01 SCHEDULE OF DATES

- A. Advertisement appears in Central Register, Plans and Specifications ready for Bidders at www.city.waltham.ma.us/bids.
- B. **Pre-bid meeting: 10:00 AM December 3, 2020.** Meet at the corner of Kenmore Road and Kenmore Terrace
- C. **Questions** and requests for interpretations may be submitted in writing via e-mail ONLY to Jpedulla@city.waltham.ma.us up to **12:00 December 4, 2020**
- D. Addenda will be issued with interpretations as determined by the Purchasing Department only via e-mail and posting on the web site.
- E. **General Bids Deadline: 10.00 A.M. December 14, 2020** in the Purchasing Department, City Hall, 610 Main Street, Waltham, MA 02452, Attn: J. Pedulla, CPO, where the bids will be publicly open and read.

1.02 BIDDING PROCEDURE

COVID-19 BID OPENING (TEMPORARY).

Based on Governor Baker's declared state of emergency, in-person bid or proposal openings are not required at the present time to satisfy Chapter 30B. If a bid is not opened at a public meeting, Chapter 30B requires that the opening be in the presence of a witness or witnesses. Under the current emergency, the opening does not need to be witnessed in person. The opening can be livestreamed for the witnesses and recorded for public record purposes. For the present time and until the emergency is lifted by Governor Baker, the City of Waltham will not hold in-person bid openings or proposals. However, the city will continue to record and prepare a spreadsheet showing all of the prices received and distribute the same to all interested parties. Copies of the same bid results will also be posted in the City web site at www.city.waltham.ma.us/bids

- A. Bids for the work are subject to the provisions of Massachusetts General Laws, Chapter 30, 39M, as amended. Regulations governing the bidding procedures as set forth in the above mentioned amended General Laws must be followed.

- B. In the event of any inconsistencies between any of the provisions of these Contract Documents and of the cited statute, anything herein to the contrary notwithstanding, the provisions of the said statute shall control.
- C. No General Bid received by the Awarding Authority after the time respectively established herein for the opening of General Bids will be considered, regardless of the cause for the delay in the receipt of any such bid.

1.03 WITHDRAWAL OF BIDS

- A. Bids may be withdrawn prior to the time respectively established for the opening of General Bids only on written request to the Awarding Authority.

1.04 INTERPRETATION OF CONTRACT DOCUMENTS

- A. No oral interpretation will be made to any bidder. All questions or requests for interpretations must be made in writing ONLY to jpedulla@city.waltham.ma.us.
- B. Every interpretation made to a bidder will be in the form of an Addendum to the drawings and/or specifications, which will be made available to all persons to whom Contract Documents have been issued.
- C. Failure of the Awarding Authority to send or of any bidder to receive any such Addendum shall not relieve any bidder from obligation under his bid as submitted.
- D. All such Addenda shall become a part of the Contract Documents.

1.05 EXAMINATION OF SITE AND CONTRACT DOCUMENTS

- A. Each bidder may visit the site of the proposed work and fully acquaint himself with conditions as they exist, and may also thoroughly examine the Contract Documents. Failure of any bidder to visit the site and acquaint himself with the Contract Documents shall not relieve any bidder from any obligation with respect to his bid.
- B. By submitting a bid, the bidder agrees that the Contract Documents are adequate and that the required result for a full and complete installation can be produced. The successful bidder shall furnish any and all labor, materials, insurance, permits and all other items needed to produce the required result to the satisfaction of the Awarding Authority.

1.06 BID SECURITY

- A. The General Contractor's bid must be accompanied by bid security in the amount of five percent (5%) of the bid.

- B. At the option of the bidder, the security may be bid bond, certified, treasurer's or cashier's check issued by a responsible bank or trust company. No other type of bid security is acceptable.

Bid Bonds shall be issued by a Surety Company qualified to do business under the laws of the Commonwealth of Massachusetts.

- C. Certified, Treasurer's or Cashier's check shall be made payable to the City of Waltham, Massachusetts.
- D. The bid security shall secure the execution of the Contract and the furnishing of a Performance and Payment Bond by the successful General Bidder for 100% of the contract value.
- E. Should any General Bidder to whom an award is made fail to enter into a contract therefore within five (5) days, Saturdays, Sundays and Legal Holidays, excluded, after notice of award has been mailed to him or fail within such time to furnish a Performance Bond and also a Labor and Materials or Payment Bond as required, the amount so received from such General Bidder through his Bid Bond, Certified, Treasurer's or Cashier's check as bid deposit shall become the property of the City of Waltham, Massachusetts as liquidated damages; provided that the amount of the bid deposit, which becomes the property of the City of Waltham, Massachusetts, shall not in any event exceed the difference between his bid price and the bid price of the next lowest responsible and eligible bidder; and provided further that, in case of death, disability, bona fide clerical error or mechanical error of a substantial nature, or other unforeseen circumstances affecting the General Bidder, his deposit shall be returned to him.

1.07 BID FORM

- A. General Bids shall be submitted on the "FORM FOR GENERAL BID" enclosed. Erasures or other changes must be explained or noted over the signature of the bidder.
- B. Bid forms must be completely filled in. Bids which are incomplete, conditional, or obscure, or which contain additions not called for will be rejected.
- C. General Bidders shall submit one set of executed bid forms to the Awarding Authority.

1.08 SUBMISSION OF BIDS AND BID SECURITIES

- A. Each bid submitted by a General Contractor shall be enclosed in a sealed envelope that shall be placed with the bid security in an outer envelope. The outer envelope shall be sealed and clearly marked as follows:

(Firm Name): Kenmore Terrace Sewer Main Replacement Project

1.09 AWARD OF CONTRACT

- A. The Contract shall be awarded to the lowest responsible and eligible General Bidder on the basis of competitive bids in accordance with the procedure set forth in the provision of Chapter 30, §39M of the General Laws of the Commonwealth of Massachusetts.
- B. If the bidder selected as the General Contractor fails to perform his agreement to execute a contract in accordance with the terms of his General Bid, and furnish a Performance Bond and also a Labor and Materials or Payment Bond, as stated in his General Bid an award shall be made to the next lowest responsible and eligible bidder.
- C. The words “lowest responsible and eligible bidder” shall be the bidder whose name is the lowest of those bidders possessing the skill, ability and integrity necessary for the faithful performance of the work and who shall certify that he is able to furnish labor that can work in harmony with all other elements of labor employed, or to be employed, on the work. Essential information in regard to such qualifications shall be submitted in such form as the Awarding Authority may require.
- D. Action on the award will be taken within sixty (60) days, Saturdays, Sundays and Legal Holidays excluded after the opening of the bids.

1.10 SECURITY FOR FAITHFUL PERFORMANCE

- A. The successful bidder must deliver to the Awarding Authority simultaneously with his delivery of the executed contract, an executed Performance Bond, and also a Labor and materials or Payment Bond, each issued by a surety company qualified to do business under the laws of the Commonwealth and satisfactory to the Awarding Authority and each in the sum of One Hundred Percent (100%) of the Contract Price, as surety for the faithful performance of his contract, and for the payment of all persons performing labor or furnishing materials in connection therewith. Said bonds shall provide that, if the General Contractor fails or refuses to complete the Contract, the Surety Company will be obligated to do so.
- B. Premiums are to be paid by the General Contractor, and are to be included in the Contract Price.

1.11 EQUAL OPPORTUNITY

- A. The City of Waltham is an Equal Opportunity employer and will require compliance with the minority business enterprise plan (MBE) on file in the Purchasing Department

1.12 PRE-BID WALK-THRU

- A. A pre-bid conference will be held **10:00 AM December 3, 2020. Meet at the corner of Kenmore Road and Kenmore Terrace, Waltham, MA 02451.** Interested parties are

encouraged to attend this meeting to become more familiar with the project prior to the submission of bids.

1.13 INTENTIONALLY LEFT BLANK

1.14 CONTRACT DOCUMENTS

- A. The Awarding Authority shall make available the bid documents and addenda in the City Web site at www.city.waltham.ma.us/bids. No plans will be mailed.

1.15 EQUALITY

- A. Except where otherwise specifically provided to the contrary, the words “or approved equal” are hereby inserted immediately following the name or description of each article, assembly, system, or any component part thereof in the Contract Documents. It is the Contractor’s responsibility to provide all the research and documentation that would prove a product or assembly is “equal”. Failure to provide research or documentation does not alleviate the Contractor’s responsibility to meet the schedule.

1.16 TAX FREE NUMBER

- A. The City of Waltham has a tax-free number.

1.17 SCHEDULE

- A. The work of the Contract shall be Substantially Complete in **within 90 calendar days (water main) and final completion within 180 calendar days (final paving)** after the date of the Notice-to-Proceed and **not including weather-related shut-downs**.

1.18 INTENTIONALLY LEFT BLANK

1.19 WEEKLY JOB MEETINGS

- A. There will be a weekly job meeting at the site on the same agreed-upon day and time. Time will be provided to discuss and view the progress of the work and to answer questions. The Contractor’s job Superintendent and Project Manager shall attend each meeting. The City reserves the right to have job meetings conducted in the location of its choosing.

1.20 PROJECT SUPERINTENDENT

- A. The Contractor shall provide the same person as Superintendent for the entire duration of the project. Failure to maintain the same person in this position shall result in a One Thousand Dollar (\$1,000.00) penalty per incident which shall cover the Architect’s time to re-orient new personnel.

1.21 AWARD

- A. The Awarding Authority reserves the right to reject any or all bids if it be in the public interest to do so, and to act upon the bids and make its award in any lawful manner. An award shall be made no less than 90 days from the Bid Opening Date.

1.22 PREVAILING WAGE SCHEDULE

- A. Bids shall be made on the basis of the Prevailing Wage Schedule, as determined by the Commissioner of Labor and Industries, pursuant to the provision of the Massachusetts General Laws. The Prevailing wage Schedule for this project can be found in the City's web Site at www.city.waltham.ma.us/bids

1.23 CONFLICT OF INTEREST

- A. A bidder filing a proposal thereby certifies that the proposal is made in good faith, without fraud, collusion, or connection of any kind with any other bidder for the same work, and that the bidder is competing solely on its own behalf without connection with, or obligation to, any undisclosed person or firm.

1.24 PROCEED ORDERS

- A. No bidder is to proceed without a proceed order as set out in the contract.

1.25 INTENTIONALLY LEFT BLANK

1.26 COMPLIANCE WITH MASSACHUSETTS GENERAL LAWS

- A. Pursuant to Massachusetts General Laws, Chapter 62C, Section 49A, I certify under the penalty of perjury that I, to the best of my knowledge and belief have filed all state tax returns and paid all the state taxes required under law.

1.27 CONSTRUCTION BARRICADES

- A. The General Contractor shall provide all barricades to enclose the work area to prevent unauthorized access to the site.
1. The barricades shall provide enough room for all construction activities to be performed while separated from pedestrians, students, and staff on site.
 2. Safety is the sole responsibility of the Contractor and any barricades necessary to protect the work and the public shall be provided.
 3. Provide entrance protection.

1.28 INSURANCE

- A. The contractor shall purchase and maintain, at his expense all insurance required by the Contract. Documents and all insurance required by the applicable laws of Massachusetts, including but not limited to, General Laws, Chapter 146, in connection with all hoisting equipment.
- B. The Contractor shall purchase and maintain such insurance as will protect him from claims under workmen's compensation acts and from claims for damages because of bodily injury, including death and all property damage including, without limitation, damage to buildings and adjoining the site of construction which might arise from and during operations under this contract, whether such operations be by himself or by any subcontractor or anyone directly or indirectly employed by either of them including:

1. Statutory Worker's Compensation and Employer's Liability

The contractor shall provide insurance for the payment of compensation and the furnishing of other benefits under Chapter 152 of the General Laws (so-called Worker's Compensation Act) to all persons to be employed under this contract and shall continue in force such insurance as aforesaid shall be deemed a material breach of this Contract and shall operate as an immediate termination thereof. The contractor shall, without limiting the generality of the foregoing, conform to the provisions of Section 34A of Chapter 149 of the General Laws, which Section is incorporated herein by reference and made a part of hereof.

2. Comprehensive General Liability Insurance

Minimum bodily injury limits of \$ 1,000,000 per person and \$ 1,000,000 per accident, and property damage limits of \$ 500,000 per accident and \$ 1,000,000 aggregate during any 12-month period, shall include the following:

- a. Public liability (bodily injury and property damage)
- b. X.C.U. (explosion, collapse, and underground utilities)
- c. Independent contractor's protective liability.
- d. Products and completed operations.
- e. Save harmless agreement for Owner and Architects set forth in ARTICLE 10.11 of the GENERAL CONDITIONS.

3. Comprehensive All Risk Motor Vehicle Liability Insurance

Minimum bodily injury limits of \$ 500,000 per person, \$ 1,000,000 per accident, and property damage limit of \$ 1,000,000 per accident.

4. All Risk Insurance

Covering all Contractors' equipment with a provision for Waiver of Subrogation against the Owner.

5. Excess Liability Insurance in Umbrella Form with combined Bodily Injury and Property Damage Limit of \$ 1,000,000.
6. **City of Waltham shall be a Named Additional Insured with a Waiver of Subrogation on the insurance policy for this project.**

1.29 SITE ACCESS

- A. The General Contractor shall gain access to the site via routes approved by the Owner.
 1. The General Contractor as part of the bid price will restore all roads, curbs, driveways, walks and grassed or landscaped areas damaged during construction.

1.30 CONSTRUCTION TRAILER

- A. The General Contractor shall locate the construction trailer at locations approved by the Owner.
- B. The General Contractor shall locate all on site stored or staged materials within the enclosed area designated by the Owner.

1.31 INTENTIONALLY LEFT BLANK

1.32 COMPLETE BID FORMS

- A. Please Note: Each bidder must fill in all the blanks on all the bid forms, even if the information is "zero dollars" or "not applicable". Also, please acknowledge all Addenda issued by the Awarding Authority.

2.00 FUNDS APPROPRIATION and LOAN AUTHORIZATION.

- A. **THE CONTRACT OBLIGATION ON BEHALF OF THE CITY IS SUBJECT TO PRIOR APPROPRIATION OF MONIES FROM THE GOVERNMENTAL BODY AND AUTHORIZATION BY THE MAYOR.**

3.0 CITY ORDINANCE. APPROVAL OF CONTRACTS BY MAYOR, SEC. 3-12 OF THE CITY ORDINANCES.

- A. All contract made by any department, board or commission where the amount involved is two thousand dollars (\$2,000) or more shall be in writing, and no such contract shall be deemed to have been made or executed until the approval of the Mayor is affixed thereto. Any construction contract shall, and all other contracts may, where the contract

exceed five thousand dollars (\$5,000) be required to be accompanied by a bond with sureties satisfactory to the Mayor

Signature of Individual or Corporate Name

By:

(Signature of Corporate Officer if applicable)

Title: _____

Social Security Number or Federal Identification Number: _____

END OF SECTION

Section 00 20 00

Compliance

The documents in this section shall bear "wet" Original signatures and returned with your bid

Compliance

The compliance documents in this section must be completed, signed and returned **with your bid package.**

Purchasing Department

City of Waltham
610 Main Street
Waltham, MA 02452

Failure to submit the completed documents will cause the disqualification of the proposal.

Section Index

Check when Complete

- Non-collusion form and Tax Compliance form..... _____
- Corporation Identification Form..... _____
- Certificate of Vote Authorization..... _____
- Certificate of Insurance (showing all limits of WC &GL)..... _____
- Three (3) References..... _____
- 5% Bid Bond or Certified Check>..... _____
- Debarment Certificate _____
- Prevailing Wage Certificate..... _____
- Right-to-know Law..... _____
- OSHA 10 Certificate for all Assigned Employees (MGL ch30, §39M and Ch 149) _____

Before the commencement of the Job, the contractor must provide to the above office:

- Performance and Payment Bonds **each** for 100% of the contract value and naming the City of Waltham

Your Company's Name: _____

Service or Product Bid _____

NOTE: Failure to submit any of the required documents, in this or in other sections, with your bid response package may cause the disqualification of your proposal.

Wet Signature Required

NON-COLLUSION FORM AND TAX COMPLIANCE FORM

CERTIFICATE OF NON-COLLUSION

The undersigned certifies under penalties of perjury that this bid or proposal has been made and submitted in good faith and without collusion or fraud with any other person. As used in this certification, the word "person" shall mean any natural person, business, partnership, corporation, union, committee, club, or other organization, entity or group of individuals. The undersigned certifies that no representations made by any City officials, employees, entity, or group of individuals other than the Purchasing Agent of the City of Waltham was relied upon in the making of this bid

_____, _____
(Signature of person signing bid or proposal) Date

(Name of business)

Wet Signature Required

TAX COMPLIANCE CERTIFICATION

Pursuant to M.G.L. c. 62C, & 49A, I certify under the penalties of perjury that, to the best of my knowledge and belief, I am in compliance with all laws of the Commonwealth relating to taxes, reporting of employees and contractors, and withholding and remitting child support.

_____, _____
Signature of person submitting bid or proposal Date

Name of business

NOTE

Failure to submit any of the required documents, in this or in other sections, with your bid response package may cause the disqualification of your proposal.

Wet Signature Required

CERTIFICATE OF VOTE OF AUTHORIZATION

Date:

I _____, Clerk of _____ hereby certify that at a meeting of the Board of Directors of said Corporation duly held on the _____ day of _____ at which time a quorum was present and voting throughout, the following vote was duly passed and is now in full force and effect:

VOTED: That _____ (*name*) is hereby authorized, directed and empowered for the name and on behalf of this Corporation to sign, seal with the corporate seat, execute, acknowledge and deliver all contracts and other obligations of this Corporation; the execution of any such contract to be valid and binding upon this Corporation for all purposes, and that this vote shall remain in full force and effect unless and until the same has been altered, amended or revoked by a subsequent vote of such directors and a certificate of such later vote attested by the Clerk of this Corporation.

I further certify that _____ is duly elected/appointed _____ of said corporation

SIGNED:

(Corporate Seal)

Clerk of the Corporation:

Print Name: _____

COMMONWEALTH OF MASSACHUSETTS

County of _____

Date:

Then personally appeared the above named and acknowledged the foregoing instrument to be their free act and deed before me, _____

Notary Public;

My Commission expires: _____

Wet Signature Required

CORPORATION IDENTIFICATION

The bidder for the information of the Awarding Authority furnishes the following information.

If a Corporation:

Incorporated in what state _____

President _____

Treasurer _____

Secretary _____

Federal ID Number _____

If a foreign (out of State) Corporation – Are you registered to do business in Massachusetts?

Yes _____, No _____

If you are selected for this work you are required under M.G.L.ch. 30S, 39L to obtain from the Secretary of State, Foreign Corp. Section, State House, Boston, a certificate stating that you Corporation is registered, and furnish said certificate to the Awarding Authority prior to the award.

If a Partnership: (Name all partners)

Name of partner _____

Residence _____

Name of partner _____

Residence _____

If an Individual:

Name _____

Residence _____

If an Individual doing business under a firm's name:

Name of Firm _____

Name of Individual _____

Business Address _____

Residence _____

Date _____

Name of Bidder _____

By _____

Signature _____

Title _____

Business Address _____ (POST OFFICE BOX NUMBER NOT ACCEPTABLE)

State Telephone Number _____

Today's Date _____

PROVIDE THREE (3) SERVICE APPROPRIATE REFERENCES

1. Company Name:

Address:

Contact Name:

Phone #

Type of service/product provided to this Company:

Dollar value of service provided to this Company:

2. Company Name:

Address:

Contact Name:

Phone #

Type of service/product provided to this Company:

Dollar value of service provided to this Company:

3. Company Name:

Address:

Contact Name:

Phone #

Type of service/product provided to this Company:

Dollar value of service provided to this Company:

NOTE

Failure to submit any of the required documents, in this or in other sections, with your bid response package will be cause for the disqualification of your company.

**WEEKLY PAYROLL RECORDS REPORT &
STATEMENT OF COMPLIANCE**

In accordance with Massachusetts General Law c. 149, §27B, a true and accurate record must be kept of all persons employed on the public works project for which the enclosed rates have been provided, A Payroll Form has been printed on the reverse of this page and includes all the information required to be kept by law. Every contractor or subcontractor is required to keep these records and preserve them for a period of three years from the date of completion of the contract.

In addition, every contractor and subcontractor is required to submit, on a weekly basis, a copy of his or her weekly payroll records to the awarding authority. For every week in which an apprentice is employed, a photocopy of the apprentice's identification card must be attached to the payroll report. Once collected, the awarding authority is also required to preserve those reports for three years.

In addition, each such contractor, subcontractor, or public body shall furnish to the awarding authority directly, within fifteen days after completion of its portion of the work, a statement, executed by the contractor, subcontractor or public body who supervises the payment of wages, in the following form:

STATEMENT OF COMPLIANCE

_____, 200_____

I _____,
(Name of signatory party) (Title)

I do hereby state that I pay or supervise the payment of the persons employed by

_____ on the _____
(Contractor, subcontractor or public body) (Building or project)

and that all mechanics and apprentices, teamsters, chauffeurs and laborers employed on said project have been paid in accordance with wages determined under the provisions of sections twenty-six and twenty-seven of chapter one hundred and forty nine of the General Laws.

Signature _____, Title _____

Print _____

Wet Signature Required**RIGHT TO KNOW LAW**

Any vendor who receives an order or orders resulting from this invitation agrees to submit a Material Safety Data Sheet (MSDS) for each toxic or hazardous substance or mixture containing such substance, pursuant to M.G.L. c. 111F, §§8,9 and 10 and the regulations contained in 441 CMR 21.06 when deliveries are made. The vendor agrees to deliver all containers properly labeled pursuant to M.G.L. c. 111F §7 and regulations contained in 441 CMR 21.05. Failure to furnish MSDS and/or labels on each container may result in civil or criminal penalties, including bid debarment and action to prevent the vendor from selling said substances, or mixtures containing said substances within the Commonwealth. All vendors furnishing substances or mixtures subject to Chapter 111F or M.G.L. are cautioned to obtain and read the laws, rules and regulations referenced above. Copies may be obtained from the State House Bookstore, Secretary of State, State House, Room 117, Boston, MA (617) 727-2834.

Authorized Signature Indicating Compliance with the Right-to-know laws:

Signature

Date

Print Name

NOTE

Failure to submit any of the required documents, in this or in other sections, with your bid response package may cause the disqualification of your proposal.

Wet Signature Required**DEBARMENT CERTIFICATION**

In connection with this bid and all procurement transactions, by signature thereon, the respondent certifies that neither the company nor its principals are suspended, debarred, proposed for debarment, declared ineligible, or voluntarily excluded from the award of contracts, procurement or non procurement programs from the Commonwealth of Massachusetts, the US Federal Government and /or the City of Waltham. "Principals" means officers, directors, owners, partners and persons having primary interest, management or supervisory responsibilities with the business entity. Vendors shall provide immediate written notification to the Purchasing Agent of the City of Waltham at any time during the period of the contract of prior to the contract award if the vendor learns of any changed condition with regards to the debarment of the company or its officers. This certification is a material representation of fact upon which reliance will be placed when making the business award. If at any time it is determined that the vendor knowingly misrepresented this certification, in addition to other legal remedies available to the city of Waltham, the contract will be cancelled and the award revoked.

Company Name _____

Address _____

City _____, State _____, Zip Code _____

Phone Number (____) _____

E-Mail Address _____

Signed by Authorized Company Representative:

Print name _____,

Date _____

Wet Signature Required

10 HOURS OSHA TRAINING CONFIRMATION

Chapter 306 of the Acts of 2004

CONSTRUCTION PROJECTS

AN ACT RELATIVE TO THE HEALTH AND SAFETY ON PUBLIC

The undersigned hereby certifies that all employees to be employed at a worksite for construction, reconstruction, alteration, remodeling, repair, installation, demolition, maintenance or repair of any public work or any public building estimated to cost more than \$10,000.00 have successfully completed a course in construction safety and health approved by the **United States Occupational Safety and Health Administration** that is at least **10 hours** in duration at the time the employee begins work and who shall furnish documentation of successful completion of said course with the first payroll report for each employee and will comply with all laws and regulations applicable to awards of subcontracts subject to section 44F.

Company Name: _____

Address: _____

Signature: _____

Title: _____

Print Name _____

Date _____

See Chapter 306 of the Acts of 2004

NOTE

Failure to submit any of the required documents, in this or in other sections, with your bid response package will be cause for the disqualification of your company.

SECTION 300

BID FORM

To the Chief Procurement Officer, City of Waltham, Massachusetts:

Regarding: Kenmore Terrace Main Replacement

The Owner reserves the right to reject any bid in the event that any bid item or items are obviously unbalanced or appear to the Owner to be so unbalanced as to affect or to be liable to affect adversely any interest of the Owner.

The Owner reserves the right to reject any or all bids if it deems it to be in its best interest to do so. The Owner reserves the right to award the Contract based on sufficiency of appropriated funds to complete the work.

The undersigned states that no officer, agent, or employees of the Owner directly or indirectly have a financial interest in this Bid.

The undersigned, as Contractor, declares as follows:

- The only parties interested in this Bid as Principals are named herein
- This Bid is made without collusion with any other person, firm, or corporation
- No officer, agent, or employee of the Owner is directly or indirectly interested in this Bid
- The Contractor has carefully examined the proposed Work and fully informed and satisfied himself as to the conditions there existing, the character and requirements of the proposed Work, the difficulties attendant upon its execution and the accuracy of all estimated quantities stated in this Bid, and has carefully read and examined the annexed proposed AGREEMENT and the Specifications and other Contract Documents therein referred to and knows and understands the terms and provisions thereof
- Understands that information relative to subsurface and other conditions, natural phenomena, existing pipes, and other structures (surface and/or subsurface) has been furnished only for his information and convenience without any warranty or guarantee, expressed or implied, that the subsurface and/or other conditions, natural phenomena, existing pipes, and other structures (surface and/or subsurface) actually encountered will be the same as those shown within the Contract Documents and agrees that the Contractor shall not use or be entitled to use any such information made available to him through Contract Documents or otherwise or obtained by him in his own examination of the site, as a basis of or ground for any claim against the Owner of the Engineer arising from or by reason of any variance which may exist between the aforesaid information made available to or acquired by him and the subsurface and/or other conditions, natural phenomena, existing pipes, and other structures (surface and/or subsurface) actually encountered during the construction work, and has made due allowance therefore in this BID

- The Contractor understands that the quantities of work tabulated in this Bid or indicated in the Specifications of other Contract Documents are only approximate and are subject to increase or decrease as deemed necessary by the Engineer
- The Contractor agrees that, if this BID is accepted will contract with the Owner, as provided in the copy of the Contract Documents deposited in the office of the Engineer, this BID from being part of said Contract Documents, and that the Contractor will perform all the work and furnish all the materials and equipment, and provide all labor, services, plant, machinery, apparatus, appliances, tools, supplies, and all other things required by the Contract Documents in the manner and within the time therein prescribes and according to the requirements of the Engineer as therein set forth, and that the Contractor will take in full payment therefore the lump sum or unit price applicable to each item of the Work as states in the schedule below

Contractors must bid on each Item.

Refer to Section Special Provisions for Measurement and Payment for Item Descriptions.

KENMORE TERRACE SEWER MAIN REPLACEMENT PROJECT
BID FORM

The Base Bid includes all the work of the Contractor

ITEM	QUANTIT Y	UNI T	ITEM DESCRIPTION WITH UNIT BID PRICE WRITTEN IN WORDS	UNIT PRICE	AMOUNT
120.1	50*	CY	UNCLASSIFIED EXCAVATION per cubic yard		
129	1150	SY	PAVEMENT MILLING per square yard		
141.1	50*	CY	TEST PIT FOR EXPLORATION per cubic yard		
144	10*	CY	CLASS B ROCK EXCAVATION per cubic yard		
151	50*	CY	GRAVEL BORROW per cubic yard		
156	50*	CY	CRUSHED STONE per cubic yard		
182.2	45	FT	REMOVAL OF ASBESTOS per each		
210	2	EA	SANITARY SEWER MANHOLE per each		
220	2	EA	DRAINAGE STRUCTURE ADJUSTED per each		
220.2	10*	VLF	DRAINAGE STRUCTURE REBUILT per vertical linear foot		
221	2	EA	FRAME AND GRATE (OR COVER) MUNICIPAL STANDARD per each		
250.04	45	FT	4 INCH PVC SANITARY SEWER PIPE per foot		
250.08	135	FT	8 INCH PVC SANITARY SEWER PIPE per foot		

ITEM	QUANTIT Y	UNI T	ITEM DESCRIPTION WITH UNIT BID PRICE WRITTEN IN WORDS	UNIT PRICE	AMOUNT
290	1	LS	BYPASS PUMPING per lump sum		
347.1	75	FT	1 INCH COPPER TUBING TYPE K per foot		
358	3	EA	GATE BOX ADJUSTED per each		
363.1	1	EA	1 INCH CORPORTAION COCK per each		
381.01	1	EA	SERVICE BOX MUNICIPAL STANDARD per each		
384	1	EA	CURB STOP per each		
460	200*	TON	HOT MIX ASPHALT per ton		
464	60	GAL	BITUMEN FOR TACK COAT per gallon		
472.2	1,500	SY	HOT MIX ASPHALT FOR PERMANENT per square yard		
580	50	FT	CURB REMOVED AND RESET per foot		
697.1	2	EA	SILT SACK per each		
701.2	30	SY	CEMENT CONCRETE WHEELCHAIR RAMP per Square Yard		
702	25	SY	HOT MIX ASPHALT WALK SURFACE per Square Yard		
703	50	SY	HOT MIX ASPHALT DRIVEWAY per Square Yard		
751.2	200	SY	LOAM BORROW AND SEEDING per square yard		

ITEM	QUANTIT Y	UNI T	ITEM DESCRIPTION WITH UNIT BID PRICE WRITTEN IN WORDS	UNIT PRICE	AMOUNT
850.1	1	LS	TRAFFIC CONTROL per lump sum		
999.001	200	HR	POLICE DETAILS AT FIFTY-EIGHT <u>DOLLARS AND NO CENTS</u> per hour	\$58.00	\$11,600.00
TOTAL BASE BID: (Basis for determining lowest bid)					

Price written in:

Words (Dollars and Cents)

Figures

Indeterminate quantities. These quantities are not guaranteed. Payment will be based on actual quantities constructed.

Basis of Award: The basis of award shall be at the Owner’s sole discretion.

Addenda: This BID includes Addenda numbered: _____, _____, _____, _____, _____, (To be filled in by Bidder if Addenda are issued.)

The Contractor hereby agrees that he will not withdraw this BID within sixty (60) consecutive calendar days after the actual date of the opening of Bids and that, if the Owner shall accept this BID, the Contractor will duly execute and acknowledge the AGREEMENT and furnish, duly executed and acknowledge, the required CONTRACT BONDS within ten (10) calendar days after notification that the AGREEMENT and other Contract Documents are Ready for signature.

If this BID is accepted by the Owner, the undersigned agrees to substantially complete work provided to be done under the Contract within **90 calendar days** (water main) and final completion within **180 calendar days** (final paving).

A Performance and Payment bond each in an amount equal to 100 percent of the total amount of the bid with a surety company qualified to do business in the Commonwealth of Massachusetts will be required for the faithful performance of the contract, as well as a labor and materials bond in an amount equal to 50 percent of the total bid amount.

This Proposal must bear the written signature of the Contractor or that of his duly authorized agent. If the Contractor is a corporation or a partnership, the Bid must be signed by a duly authorized officer of such corporation or by a Partner and the title of such officer must be stated. Satisfactory completion of the following data is an essential part of submission of this Proposal and is required. Bid must be embossed with corporate seal.

Company’s Name

By: _____
Authorized Signature

(SEAL)

Title

Print Name

Date: _____

Email Address

Telephone Number

Business Address

City and State

END OF SECTION 00300

Section 00 44 00

COVID-19 BID OPENING (TEMPORARY).

Based on Governor Baker's declared state of emergency, in-person bid or proposal openings are not required at the present time to satisfy Chapter 30B. If a bid is not opened at a public meeting, Chapter 30B requires that the opening be in the presence of a witness or witnesses. Under the current emergency, the opening does not need to be witnessed in person. The opening can be livestreamed for the witnesses and recorded for public record purposes. For the present time and until the emergency is lifted by Governor Baker, the City of Waltham will not hold in-person bid openings or proposals. However, the city will continue to record and prepare a spreadsheet showing all of the prices received and distribute the same to all interested parties. Copies of the same bid results will also be posted in the City web site at www.city.waltham.ma.us/bids

Section 00 45 00**DELIVERY OF SEALED BIDS**

While Waltham City Hall is closed due to the COVID-19 Emergency, to ensure that all bids are received on time, the City is asking that you follow the procedure below:

IF THE BID IS MAILED:

The best delivery service is US Postal Service. While UPS, FEDEX and other carries do not have access to City Hall, the US Postal Service delivers inside City Hall daily. It is best to use the USPS overnight service to deliver your sealed bid.

IF THE BID IS DROPPED OFF:

The best way to make sure the bid is received on time and without cutting it too close to the bid deadline, is to have the bid dropped off the weekday before the due date. When dropping off the bid the day before the due date, the City is asking that you call ahead 781-314-3244 or 781-314-3240 so that the Purchasing Department can meet you at the door to accept your bid envelope.

END OF SECTION

DELIVERY OF SEALED BIDS

00 45 00 - 1

SECTION 00500
AGREEMENT
CITY OF WALTHAM

This agreement, made this _____ day of _____, 2020 by and between the CITY OF WALTHAM, party of the first part, hereinafter called the CITY, by its MAYOR, and _____ hereinafter called the CONTRACTOR.

Witnesseth, that the parties to this agreement, each in consideration of the agreement on the part of the others herein contained, do hereby agree, the CITY OF WALTHAM for itself, and said contractor for his heirs, executors, administrators and assigns as follows:

CITY OF WALTHAM, MASSACHUSETTS

FOR THE CITY

Jeannette A. McCarthy, Mayor
City of Waltham
Date: _____

John Cervone, City Solicitor
Date: _____
APPROVED AS TO FORM ONLY

Michael Chiasson CPW Director
Date: _____

Joseph Pedulla, Purchasing Agent
Date: _____

Paul Centofanti, Auditor
Date: _____

FOR THE COMPANY

CONTRACTOR (Signature),
Date: _____

Company

Address

I CERTIFY THAT SUFFICIENT FUNDS ARE AVAILABLE FOR THIS CONTRACT

SECTION 00 05 01

PERFORMANCE BOND

CITY OF WALTHAM

KNOW ALL MEN BY THESE PRESENT THAT,

_____ as

principal and _____ as surety, are held and firmly bound unto the CITY OF WALTHAM and to such persons, firms, and corporations, who may furnish materials for or perform labor on the work, construction or improvements contemplated in the Contract hereinafter mentioned, or who may have any suits or claims for injury or damage to persons or property resulting from or arising out of the work done under this Contract, in the

SUM OF _____ DOLLARS (\$ _____)

(lawful money of the United States of America) for the payment whereof the Contractor and the Surety of Sureties bind themselves and their heirs, executors, administrators, successors and assigns, jointly and severally, firmly by these presents.

THE CONDITION OF THIS OBLIGATION IS SUCH, THAT for the above burden (the Contractor) its

_____ heirs, executors, administrators and assigns, shall faithfully perform the Contract, on his part and during the life of any guaranty or warranty, for defective materials and workmanship required under this Contract, and satisfy all claims and demands incurred for the same; and shall fully indemnify and save harmless the City from all cost and damage which it may suffer by reason of failure so to do, and shall fully reimburse and repay the City all outlay and expense which the City may incur in making good any such default, and shall promptly make payment to all persons supplying labor or materials for use in the prosecution of the work provided for in said Contract; and shall indemnify and save harmless the said City, its officers and agents from any and all suits or claims for injury or damage to persons or property resulting from or arising out of the work done under this Contract, then this obligation shall be null and void; otherwise it shall remain in full force and effect.

PROVIDED, HOWEVER, that (except as to the City) no suit, action or proceeding by reason of any default whatever shall be brought on this Bond after two years from the day on which the final payment under the Contract falls due.

AND PROVIDED, that any alterations which may be made in the terms of the Contract or in the work to be done under it, or any assignment, transfer or subletting of any part of the work, or the giving by the City of any extension of time for the performance of the Contract, or any other forbearance on the part of either the City or the Contractor to the other, shall not in any way release the Contractor and the Surety of Sureties, or either or any of them, their heirs, executors, administrators, successors or assigns from their liability hereunder, notice to the Surety or Sureties of any such alterations, assignment, transfer, subletting extension or forbearance being hereby waived.

This Bond is made for the use and benefit of all persons, firms, and corporations who may furnish materials, or perform any labor for or on account of said work, construction or improvements, or who may have any suits or claims for injury or damage to persons or property resulting from or arising out of the work done under this Contract, and they and each of them are hereby made obligees hereunder the same as if their own proper names were written herein as such, and they and each of them may sue hereon in their own names for their own use and benefit.

And the Surety, for value received, hereby stipulates and agrees that no change, extension of time, alteration or addition to the terms of the Contract or to the work to be performed hereunder, or the Specifications accompanying the same, shall in any way affect its obligations on this Bond, and it does hereby waive notice of any such changes, extension of time, alteration or addition to the terms of the Contract or to the work, or to the Specifications.

IN WITNESS WHEREOF, said Contractor and Surety have hereunto set their respective names this

_____ day of _____, 20_____.

WITNESSES:

(CONTRACTOR) (SEAL)

NAME _____ BY _____
(SIGNATURE AND TITLE)

ADDRESS _____
(SURETY) (SEAL)

NAME _____ BY _____
(SIGNATURE AND TITLE)

ADDRESS _____ BY _____
(ATTORNEY-IN-FACT)

POWER OF ATTORNEY

Attorneys-in-fact who sign bonds must file with each bond a certified copy of their power of attorney to sign said bonds.

SECTION 00 50 20

PAYMENT BOND

CITY OF WALTHAM

KNOW ALL MEN BY THESE PRESENT THAT,

_____ as

principal and _____ as
surety, are held and firmly bound unto the CITY OF WALTHAM and to such persons, firms, and corporations, who may furnish materials for or perform labor on the work, construction or improvements contemplated in the Contract hereinafter mentioned, or who may have any suits or claims for injury or damage to persons or property resulting from or arising out of the work done under this Contract, in the

SUM OF _____ DOLLARS (\$ _____)
(lawful money of the United States of America) for the payment whereof the Contractor and the Surety of Sureties bind themselves and their heirs, executors, administrators, successors and assigns, jointly and severally, firmly by these presents.

THE CONDITION OF THIS OBLIGATION IS SUCH, THAT for the above burden (the Contractor) its

_____ heirs, executors, administrators and assigns, shall faithfully perform the Contract, on his part and during the life of any guaranty or warranty, for defective materials and workmanship required under this Contract, and satisfy all claims and demands incurred for the same; and shall fully indemnify and save harmless the City from all cost and damage which it may suffer by reason of failure so to do, and shall fully reimburse and repay the City all outlay and expense which the City may incur in making good any such default, and shall promptly make payment to all persons supplying labor or materials for use in the prosecution of the work provided for in said Contract; and shall indemnify and save harmless the said City, its officers and agents from any and all suits or claims for injury or damage to persons or property resulting from or arising out of the work done under this Contract, then this obligation shall be null and void; otherwise it shall remain in full force and effect.

PROVIDED, HOWEVER, that (except as to the City) no suit, action or proceeding by reason of any default whatever shall be brought on this Bond after two years from the day on which the final payment under the Contract falls due.

AND PROVIDED, that any alterations which may be made in the terms of the Contract or in the work to be done under it, or any assignment, transfer or subletting of any part of the work, or the giving by the City of any extension of time for the payment of the Contract, or any other forbearance on the part of either the City or the Contractor to the other, shall not in any way release the Contractor and the Surety of Sureties, or either or any of them, their heirs, executors, administrators, successors or assigns from their liability hereunder, notice to the Surety or Sureties of any such alterations, assignment, transfer, subletting extension or forbearance being hereby waived.

This Bond is made for the use and benefit of all persons, firms, and corporations who may furnish materials, or perform any labor for or on account of said work, construction or improvements, or who

may have any suits or claims for injury or damage to persons or property resulting from or arising out of the work done under this Contract, and they and each of them are hereby made obligees hereunder the same as if their own proper names were written herein as such, and they and each of them may sue hereon in their own names for their own use and benefit.

And the Surety, for value received, hereby stipulates and agrees that no change, extension of time, alteration or addition to the terms of the Contract or to the work to be performed hereunder, or the Specifications accompanying the same, shall in any way affect its obligations on this Bond, and it does hereby waive notice of any such changes, extension of time, alteration or addition to the terms of the Contract or to the work, or to the Specifications.

IN WITNESS WHEREOF, said Contractor and Surety have hereunto set their respective names this

_____ day of _____, 20____.

WITNESSES:

(CONTRACTOR)

(SEAL)

NAME _____ BY _____
(SIGNATURE AND TITLE)

ADDRESS _____
(SURETY) (SEAL)

NAME _____ BY _____
(SIGNATURE AND TITLE)

ADDRESS _____ BY _____
(ATTORNEY-IN-FACT)

POWER OF ATTORNEY

Attorneys-in-fact who sign bonds must file with each bond a certified copy of their power of attorney to sign said bonds.

Section 00 54 00
LIQUIDATED DAMAGES

Should a Contractor fail to complete his work on or before the time set forth or as provided in the Contract Documents covering extension of time, the Owner may retain an amount of \$500.00 per calendar day as liquidated damages for each calendar day in accordance with the provisions of that section.

SECTION 00 71 00

PREVAILING WAGES

Bids shall be made on the basis of the Prevailing Wage Schedule, as determined by the Commissioner of Labor and Industries, pursuant to the provision of the Massachusetts General Laws. The Prevailing wage Schedule for this project can be found in the City's web Site at www.city.waltham.ma.us/bids

SECTION 00821PERMITSPART 1 GENERAL

1.01 CONTRACT DOCUMENTS

- A. The general provisions of the Contract, including General and Supplemental Conditions and General Requirements, apply to the work specified in this section.

1.02 PERMITS

- A. The Contractor shall be responsible for obtaining and complying with all permits required of his equipment, work force, or particular operations (such as blasting and fuel storage permits, etc.) in the performance of the Contract. All costs associated with obtaining permits will be included in the price of the work.
- B. If included as part of this project, The Contractor shall be responsible for complying with requirements of the Local Conservation Commission and the Cambridge Watershed Protection District. All costs associated with complying with the conditions will be included in the price of the work.
- C. The Contractor shall be responsible for obtaining and complying with the requirements of the Street Opening and Trench Permits required by the City Department of Public Works in the performance of the Contract. All costs associated with complying with the conditions of the permits will be included in the price of the work. All costs associated with obtaining permits will be waived by the City.

END OF SECTION

**TECHNICAL SPECIFICATIONS
&
ATTACHMENTS**

STANDARD GENERAL CONDITIONS OF THE CONSTRUCTION CONTRACT

TABLE OF CONTENTS

	Page
Article 1 – Definitions and Terminology	1
1.01 Defined Terms	1
1.02 Terminology	5
Article 2 – Preliminary Matters	6
2.01 Delivery of Bonds and Evidence of Insurance	6
2.02 Copies of Documents	6
2.03 Before Starting Construction	6
2.04 Preconstruction Conference; Designation of Authorized Representatives	7
2.05 Initial Acceptance of Schedules	7
2.06 Electronic Transmittals	7
Article 3 – Documents: Intent, Requirements, Reuse	8
3.01 Intent	8
3.02 Reference Standards	8
3.03 Reporting and Resolving Discrepancies	8
3.04 Requirements of the Contract Documents	9
3.05 Reuse of Documents	10
Article 4 – Commencement and Progress of the Work	10
4.01 Commencement of Contract Times; Notice to Proceed	10
4.02 Starting the Work	10
4.03 Reference Points	10
4.04 Progress Schedule	10
4.05 Delays in Contractor’s Progress	11
Article 5 – Availability of Lands; Subsurface and Physical Conditions; Hazardous Environmental Conditions	12
5.01 Availability of Lands	12
5.02 Use of Site and Other Areas	12
5.03 Subsurface and Physical Conditions	13
5.04 Differing Subsurface or Physical Conditions	14
5.05 Underground Facilities	15

5.06	Hazardous Environmental Conditions at Site	17
Article 6 – Bonds and Insurance		19
6.01	Performance, Payment, and Other Bonds	19
6.02	Insurance—General Provisions	19
6.03	Contractor’s Insurance	20
6.04	Owner’s Liability Insurance	23
6.05	Property Insurance	23
6.06	Waiver of Rights	25
6.07	Receipt and Application of Property Insurance Proceeds	25
Article 7 – Contractor’s Responsibilities		26
7.01	Supervision and Superintendence	26
7.02	Labor; Working Hours	26
7.03	Services, Materials, and Equipment.....	26
7.04	“Or Equals”	27
7.05	Substitutes	28
7.06	Concerning Subcontractors, Suppliers, and Others	29
7.07	Patent Fees and Royalties	31
7.08	Permits	31
7.09	Taxes	32
7.10	Laws and Regulations.....	32
7.11	Record Documents	32
7.12	Safety and Protection.....	32
7.13	Safety Representative	33
7.14	Hazard Communication Programs	33
7.15	Emergencies	34
7.16	Shop Drawings, Samples, and Other Submittals.....	34
7.17	Contractor’s General Warranty and Guarantee.....	36
7.18	Indemnification	37
7.19	Delegation of Professional Design Services	37
Article 8 – Other Work at the Site		38
8.01	Other Work	38
8.02	Coordination	39
8.03	Legal Relationships.....	39

Article 9 – Owner’s Responsibilities.....	40
9.01 Communications to Contractor.....	40
9.02 Replacement of Engineer	40
9.03 Furnish Data	40
9.04 Pay When Due.....	40
9.05 Lands and Easements; Reports, Tests, and Drawings	40
9.06 Insurance	40
9.07 Change Orders.....	40
9.08 Inspections, Tests, and Approvals.....	41
9.09 Limitations on Owner’s Responsibilities	41
9.10 Undisclosed Hazardous Environmental Condition.....	41
9.11 Evidence of Financial Arrangements.....	41
9.12 Safety Programs	41
Article 10 – Engineer’s Status During Construction.....	41
10.01 Owner’s Representative.....	41
10.02 Visits to Site.....	41
10.03 Project Representative.....	42
10.04 Rejecting Defective Work.....	42
10.05 Shop Drawings, Change Orders and Payments.....	42
10.06 Determinations for Unit Price Work	42
10.07 Decisions on Requirements of Contract Documents and Acceptability of Work	42
10.08 Limitations on Engineer’s Authority and Responsibilities.....	42
10.09 Compliance with Safety Program.....	43
Article 11 – Amending the Contract Documents; Changes in the Work	43
11.01 Amending and Supplementing Contract Documents	43
11.02 Owner-Authorized Changes in the Work	44
11.03 Unauthorized Changes in the Work	44
11.04 Change of Contract Price	44
11.05 Change of Contract Times	45
11.06 Change Proposals	45
11.07 Execution of Change Orders.....	46
11.08 Notification to Surety.....	47
Article 12 – Claims.....	47

12.01	Claims	47
Article 13 –	Cost of the Work; Allowances; Unit Price Work.....	48
13.01	Cost of the Work	48
13.02	Allowances	50
13.03	Unit Price Work	51
Article 14 –	Tests and Inspections; Correction, Removal or Acceptance of Defective Work.....	52
14.01	Access to Work.....	52
14.02	Tests, Inspections, and Approvals.....	52
14.03	Defective Work.....	53
14.04	Acceptance of Defective Work.....	53
14.05	Uncovering Work	53
14.06	Owner May Stop the Work	54
14.07	Owner May Correct Defective Work.....	54
Article 15 –	Payments to Contractor; Set-Offs; Completion; Correction Period	55
15.01	Progress Payments.....	55
15.02	Contractor’s Warranty of Title	58
15.03	Substantial Completion.....	58
15.04	Partial Use or Occupancy	59
15.05	Final Inspection	59
15.06	Final Payment.....	59
15.07	Waiver of Claims	61
15.08	Correction Period	61
Article 16 –	Suspension of Work and Termination	62
16.01	Owner May Suspend Work	62
16.02	Owner May Terminate for Cause	62
16.03	Owner May Terminate For Convenience	63
16.04	Contractor May Stop Work or Terminate	63
Article 17 –	Final Resolution of Disputes	64
17.01	Methods and Procedures.....	64
Article 18 –	Miscellaneous	64
18.01	Giving Notice	64
18.02	Computation of Times.....	64
18.03	Cumulative Remedies	64

18.04	Limitation of Damages	65
18.05	No Waiver	65
18.06	Survival of Obligations	65
18.07	Controlling Law	65
18.08	Headings.....	65

ARTICLE 1 – DEFINITIONS AND TERMINOLOGY

1.01 *Defined Terms*

- A. Wherever used in the Bidding Requirements or Contract Documents, a term printed with initial capital letters, including the term's singular and plural forms, will have the meaning indicated in the definitions below. In addition to terms specifically defined, terms with initial capital letters in the Contract Documents include references to identified articles and paragraphs, and the titles of other documents or forms.
1. *Addenda*—Written or graphic instruments issued prior to the opening of Bids which clarify, correct, or change the Bidding Requirements or the proposed Contract Documents.
 2. *Agreement*—The written instrument, executed by Owner and Contractor, that sets forth the Contract Price and Contract Times, identifies the parties and the Engineer, and designates the specific items that are Contract Documents.
 3. *Application for Payment*—The form acceptable to Engineer which is to be used by Contractor during the course of the Work in requesting progress or final payments and which is to be accompanied by such supporting documentation as is required by the Contract Documents.
 4. *Bid*—The offer of a Bidder submitted on the prescribed form setting forth the prices for the Work to be performed.
 5. *Bidder*—An individual or entity that submits a Bid to Owner.
 6. *Bidding Documents*—The Bidding Requirements, the proposed Contract Documents, and all Addenda.
 7. *Bidding Requirements*—The advertisement or invitation to bid, Instructions to Bidders, Bid Bond or other Bid security, if any, the Bid Form, and the Bid with any attachments.
 8. *Change Order*—A document which is signed by Contractor and Owner and authorizes an addition, deletion, or revision in the Work or an adjustment in the Contract Price or the Contract Times, or other revision to the Contract, issued on or after the Effective Date of the Contract.
 9. *Change Proposal*—A written request by Contractor, duly submitted in compliance with the procedural requirements set forth herein, seeking an adjustment in Contract Price or Contract Times, or both; contesting an initial decision by Engineer concerning the requirements of the Contract Documents or the acceptability of Work under the Contract Documents; challenging a set-off against payments due; or seeking other relief with respect to the terms of the Contract.
 10. *Claim*—(a) A demand or assertion by Owner directly to Contractor, duly submitted in compliance with the procedural requirements set forth herein: seeking an adjustment of Contract Price or Contract Times, or both; contesting an initial decision by Engineer concerning the requirements of the Contract Documents or the acceptability of Work under the Contract Documents; contesting Engineer's decision regarding a Change Proposal; seeking resolution of a contractual issue that Engineer has declined to address; or seeking other relief with respect to the terms of the Contract; or (b) a demand or assertion by Contractor directly to Owner, duly submitted in compliance with the procedural requirements set forth herein, contesting Engineer's decision regarding a Change Proposal; or seeking resolution of a contractual issue that Engineer

has declined to address. A demand for money or services by a third party is not a Claim.

11. *Constituent of Concern*—Asbestos, petroleum, radioactive materials, polychlorinated biphenyls (PCBs), hazardous waste, and any substance, product, waste, or other material of any nature whatsoever that is or becomes listed, regulated, or addressed pursuant to (a) the Comprehensive Environmental Response, Compensation and Liability Act, 42 U.S.C. §§9601 et seq. (“CERCLA”); (b) the Hazardous Materials Transportation Act, 49 U.S.C. §§5101 et seq.; (c) the Resource Conservation and Recovery Act, 42 U.S.C. §§6901 et seq. (“RCRA”); (d) the Toxic Substances Control Act, 15 U.S.C. §§2601 et seq.; (e) the Clean Water Act, 33 U.S.C. §§1251 et seq.; (f) the Clean Air Act, 42 U.S.C. §§7401 et seq.; or (g) any other federal, state, or local statute, law, rule, regulation, ordinance, resolution, code, order, or decree regulating, relating to, or imposing liability or standards of conduct concerning, any hazardous, toxic, or dangerous waste, substance, or material.
12. *Contract*—The entire and integrated written contract between the Owner and Contractor concerning the Work.
13. *Contract Documents*—Those items so designated in the Agreement, and which together comprise the Contract.
14. *Contract Price*—The money that Owner has agreed to pay Contractor for completion of the Work in accordance with the Contract Documents. .
15. *Contract Times*—The number of days or the dates by which Contractor shall: (a) achieve Milestones, if any; (b) achieve Substantial Completion; and (c) complete the Work.
16. *Contractor*—The individual or entity with which Owner has contracted for performance of the Work.
17. *Cost of the Work*—See Paragraph 13.01 for definition.
18. *Drawings*—The part of the Contract that graphically shows the scope, extent, and character of the Work to be performed by Contractor.
19. *Effective Date of the Contract*—The date, indicated in the Agreement, on which the Contract becomes effective.
20. *Engineer*—The individual or entity named as such in the Agreement.
21. *Field Order*—A written order issued by Engineer which requires minor changes in the Work but does not change the Contract Price or the Contract Times.
22. *Hazardous Environmental Condition*—The presence at the Site of Constituents of Concern in such quantities or circumstances that may present a danger to persons or property exposed thereto. The presence at the Site of materials that are necessary for the execution of the Work, or that are to be incorporated in the Work, and that are controlled and contained pursuant to industry practices, Laws and Regulations, and the requirements of the Contract, does not establish a Hazardous Environmental Condition.
23. *Laws and Regulations; Laws or Regulations*—Any and all applicable laws, statutes, rules, regulations, ordinances, codes, and orders of any and all governmental bodies, agencies, authorities, and courts having jurisdiction.

24. *Liens*—Charges, security interests, or encumbrances upon Contract-related funds, real property, or personal property.
25. *Milestone*—A principal event in the performance of the Work that the Contract requires Contractor to achieve by an intermediate completion date or by a time prior to Substantial Completion of all the Work.
26. *Notice of Award*—The written notice by Owner to a Bidder of Owner’s acceptance of the Bid.
27. *Notice to Proceed*—A written notice by Owner to Contractor fixing the date on which the Contract Times will commence to run and on which Contractor shall start to perform the Work.
28. *Owner*—The individual or entity with which Contractor has contracted regarding the Work, and which has agreed to pay Contractor for the performance of the Work, pursuant to the terms of the Contract.
29. *Progress Schedule*—A schedule, prepared and maintained by Contractor, describing the sequence and duration of the activities comprising the Contractor’s plan to accomplish the Work within the Contract Times.
30. *Project*—The total undertaking to be accomplished for Owner by engineers, contractors, and others, including planning, study, design, construction, testing, commissioning, and start-up, and of which the Work to be performed under the Contract Documents is a part.
31. *Project Manual*—The written documents prepared for, or made available for, procuring and constructing the Work, including but not limited to the Bidding Documents or other construction procurement documents, geotechnical and existing conditions information, the Agreement, bond forms, General Conditions, Supplementary Conditions, and Specifications. The contents of the Project Manual may be bound in one or more volumes.
32. *Resident Project Representative*—The authorized representative of Engineer assigned to assist Engineer at the Site. As used herein, the term Resident Project Representative or “RPR” includes any assistants or field staff of Resident Project Representative.
33. *Samples*—Physical examples of materials, equipment, or workmanship that are representative of some portion of the Work and that establish the standards by which such portion of the Work will be judged.
34. *Schedule of Submittals*—A schedule, prepared and maintained by Contractor, of required submittals and the time requirements for Engineer’s review of the submittals and the performance of related construction activities.
35. *Schedule of Values*—A schedule, prepared and maintained by Contractor, allocating portions of the Contract Price to various portions of the Work and used as the basis for reviewing Contractor’s Applications for Payment.
36. *Shop Drawings*—All drawings, diagrams, illustrations, schedules, and other data or information that are specifically prepared or assembled by or for Contractor and submitted by Contractor to illustrate some portion of the Work. Shop Drawings, whether approved or not, are not Drawings and are not Contract Documents.

37. *Site*—Lands or areas indicated in the Contract Documents as being furnished by Owner upon which the Work is to be performed, including rights-of-way and easements, and such other lands furnished by Owner which are designated for the use of Contractor.
38. *Specifications*—The part of the Contract that consists of written requirements for materials, equipment, systems, standards, and workmanship as applied to the Work, and certain administrative requirements and procedural matters applicable to the Work.
39. *Subcontractor*—An individual or entity having a direct contract with Contractor or with any other Subcontractor for the performance of a part of the Work.
40. *Substantial Completion*—The time at which the Work (or a specified part thereof) has progressed to the point where, in the opinion of Engineer, the Work (or a specified part thereof) is sufficiently complete, in accordance with the Contract Documents, so that the Work (or a specified part thereof) can be utilized for the purposes for which it is intended. The terms “substantially complete” and “substantially completed” as applied to all or part of the Work refer to Substantial Completion thereof.
41. *Successful Bidder*—The Bidder whose Bid the Owner accepts, and to which the Owner makes an award of contract, subject to stated conditions.
42. *Supplementary Conditions*—The part of the Contract that amends or supplements these General Conditions.
43. *Supplier*—A manufacturer, fabricator, supplier, distributor, materialman, or vendor having a direct contract with Contractor or with any Subcontractor to furnish materials or equipment to be incorporated in the Work by Contractor or a Subcontractor.
44. *Technical Data*—Those items expressly identified as Technical Data in the Supplementary Conditions, with respect to either (a) subsurface conditions at the Site, or physical conditions relating to existing surface or subsurface structures at the Site (except Underground Facilities) or (b) Hazardous Environmental Conditions at the Site. If no such express identifications of Technical Data have been made with respect to conditions at the Site, then the data contained in boring logs, recorded measurements of subsurface water levels, laboratory test results, and other factual, objective information regarding conditions at the Site that are set forth in any geotechnical or environmental report prepared for the Project and made available to Contractor are hereby defined as Technical Data with respect to conditions at the Site under Paragraphs 5.03, 5.04, and 5.06.
45. *Underground Facilities*—All underground pipelines, conduits, ducts, cables, wires, manholes, vaults, tanks, tunnels, or other such facilities or attachments, and any encasements containing such facilities, including but not limited to those that convey electricity, gases, steam, liquid petroleum products, telephone or other communications, fiber optic transmissions, cable television, water, wastewater, storm water, other liquids or chemicals, or traffic or other control systems.
46. *Unit Price Work*—Work to be paid for on the basis of unit prices.
47. *Work*—The entire construction or the various separately identifiable parts thereof required to be provided under the Contract Documents. Work includes and is the result of performing or providing all labor, services, and documentation necessary to produce such construction; furnishing, installing, and incorporating all materials and equipment into such construction; and may include related services such as testing, start-up, and commissioning, all as required by the Contract Documents.

48. *Work Change Directive*—A written directive to Contractor issued on or after the Effective Date of the Contract, signed by Owner and recommended by Engineer, ordering an addition, deletion, or revision in the Work.

1.02 Terminology

- A. The words and terms discussed in the following paragraphs are not defined but, when used in the Bidding Requirements or Contract Documents, have the indicated meaning.
- B. *Intent of Certain Terms or Adjectives:*
1. The Contract Documents include the terms “as allowed,” “as approved,” “as ordered,” “as directed” or terms of like effect or import to authorize an exercise of professional judgment by Engineer. In addition, the adjectives “reasonable,” “suitable,” “acceptable,” “proper,” “satisfactory,” or adjectives of like effect or import are used to describe an action or determination of Engineer as to the Work. It is intended that such exercise of professional judgment, action, or determination will be solely to evaluate, in general, the Work for compliance with the information in the Contract Documents and with the design concept of the Project as a functioning whole as shown or indicated in the Contract Documents (unless there is a specific statement indicating otherwise). The use of any such term or adjective is not intended to and shall not be effective to assign to Engineer any duty or authority to supervise or direct the performance of the Work, or any duty or authority to undertake responsibility contrary to the provisions of Article 10 or any other provision of the Contract Documents.
- C. *Day:*
1. The word “day” means a calendar day of 24 hours measured from midnight to the next midnight.
- D. *Defective:*
1. The word “defective,” when modifying the word “Work,” refers to Work that is unsatisfactory, faulty, or deficient in that it:
 - a. does not conform to the Contract Documents; or
 - b. does not meet the requirements of any applicable inspection, reference standard, test, or approval referred to in the Contract Documents; or
 - c. has been damaged prior to Engineer’s recommendation of final payment (unless responsibility for the protection thereof has been assumed by Owner at Substantial Completion in accordance with Paragraph 15.03 or 15.04).
- E. *Furnish, Install, Perform, Provide:*
1. The word “furnish,” when used in connection with services, materials, or equipment, shall mean to supply and deliver said services, materials, or equipment to the Site (or some other specified location) ready for use or installation and in usable or operable condition.
 2. The word “install,” when used in connection with services, materials, or equipment, shall mean to put into use or place in final position said services, materials, or equipment complete and ready for intended use.

3. The words “perform” or “provide,” when used in connection with services, materials, or equipment, shall mean to furnish and install said services, materials, or equipment complete and ready for intended use.
 4. If the Contract Documents establish an obligation of Contractor with respect to specific services, materials, or equipment, but do not expressly use any of the four words “furnish,” “install,” “perform,” or “provide,” then Contractor shall furnish and install said services, materials, or equipment complete and ready for intended use.
- F. Unless stated otherwise in the Contract Documents, words or phrases that have a well-known technical or construction industry or trade meaning are used in the Contract Documents in accordance with such recognized meaning.

ARTICLE 2 – PRELIMINARY MATTERS

2.01 *Delivery of Bonds and Evidence of Insurance*

- A. *Bonds*: When Contractor delivers the executed counterparts of the Agreement to Owner, Contractor shall also deliver to Owner such bonds as Contractor may be required to furnish.
- B. *Evidence of Contractor’s Insurance*: When Contractor delivers the executed counterparts of the Agreement to Owner, Contractor shall also deliver to Owner, with copies to each named insured and additional insured (as identified in the Supplementary Conditions or elsewhere in the Contract), the certificates and other evidence of insurance required to be provided by Contractor in accordance with Article 6.
- C. *Evidence of Owner’s Insurance*: After receipt of the executed counterparts of the Agreement and all required bonds and insurance documentation, Owner shall promptly deliver to Contractor, with copies to each named insured and additional insured (as identified in the Supplementary Conditions or otherwise), the certificates and other evidence of insurance required to be provided by Owner under Article 6.

2.02 *Copies of Documents*

- A. Owner shall furnish to Contractor four printed copies of the Contract (including one fully executed counterpart of the Agreement), and one copy in electronic portable document format (PDF). Additional printed copies will be furnished upon request at the cost of reproduction.
- B. Owner shall maintain and safeguard at least one original printed record version of the Contract, including Drawings and Specifications signed and sealed by Engineer and other design professionals. Owner shall make such original printed record version of the Contract available to Contractor for review. Owner may delegate the responsibilities under this provision to Engineer.

2.03 *Before Starting Construction*

- A. *Preliminary Schedules*: Within 10 days after the Effective Date of the Contract (or as otherwise specifically required by the Contract Documents), Contractor shall submit to Engineer for timely review:
 1. a preliminary Progress Schedule indicating the times (numbers of days or dates) for starting and completing the various stages of the Work, including any Milestones specified in the Contract;
 2. a preliminary Schedule of Submittals; and

3. a preliminary Schedule of Values for all of the Work which includes quantities and prices of items which when added together equal the Contract Price and subdivides the Work into component parts in sufficient detail to serve as the basis for progress payments during performance of the Work. Such prices will include an appropriate amount of overhead and profit applicable to each item of Work.

2.04 *Preconstruction Conference; Designation of Authorized Representatives*

- A. Before any Work at the Site is started, a conference attended by Owner, Contractor, Engineer, and others as appropriate will be held to establish a working understanding among the parties as to the Work and to discuss the schedules referred to in Paragraph 2.03.A, procedures for handling Shop Drawings, Samples, and other submittals, processing Applications for Payment, electronic or digital transmittals, and maintaining required records.
- B. At this conference Owner and Contractor each shall designate, in writing, a specific individual to act as its authorized representative with respect to the services and responsibilities under the Contract. Such individuals shall have the authority to transmit and receive information, render decisions relative to the Contract, and otherwise act on behalf of each respective party.

2.05 *Initial Acceptance of Schedules*

- A. At least 10 days before submission of the first Application for Payment a conference, attended by Contractor, Engineer, and others as appropriate, will be held to review for acceptability to Engineer as provided below the schedules submitted in accordance with Paragraph 2.03.A. Contractor shall have an additional 10 days to make corrections and adjustments and to complete and resubmit the schedules. No progress payment shall be made to Contractor until acceptable schedules are submitted to Engineer.
 1. The Progress Schedule will be acceptable to Engineer if it provides an orderly progression of the Work to completion within the Contract Times. Such acceptance will not impose on Engineer responsibility for the Progress Schedule, for sequencing, scheduling, or progress of the Work, nor interfere with or relieve Contractor from Contractor's full responsibility therefor.
 2. Contractor's Schedule of Submittals will be acceptable to Engineer if it provides a workable arrangement for reviewing and processing the required submittals.
 3. Contractor's Schedule of Values will be acceptable to Engineer as to form and substance if it provides a reasonable allocation of the Contract Price to the component parts of the Work.

2.06 *Electronic Transmittals*

- A. Except as otherwise stated elsewhere in the Contract, the Owner, Engineer, and Contractor may transmit, and shall accept, Project-related correspondence, text, data, documents, drawings, information, and graphics, including but not limited to Shop Drawings and other submittals, in electronic media or digital format, either directly, or through access to a secure Project website.
- B. If the Contract does not establish protocols for electronic or digital transmittals, then Owner, Engineer, and Contractor shall jointly develop such protocols.
- C. When transmitting items in electronic media or digital format, the transmitting party makes no representations as to long term compatibility, usability, or readability of the items resulting from the recipient's use of software application packages, operating systems, or

computer hardware differing from those used in the drafting or transmittal of the items, or from those established in applicable transmittal protocols.

ARTICLE 3 – DOCUMENTS: INTENT, REQUIREMENTS, REUSE

3.01 *Intent*

- A. The Contract Documents are complementary; what is required by one is as binding as if required by all.
- B. It is the intent of the Contract Documents to describe a functionally complete project (or part thereof) to be constructed in accordance with the Contract Documents.
- C. Unless otherwise stated in the Contract Documents, if there is a discrepancy between the electronic or digital versions of the Contract Documents (including any printed copies derived from such electronic or digital versions) and the printed record version, the printed record version shall govern.
- D. The Contract supersedes prior negotiations, representations, and agreements, whether written or oral.
- E. Engineer will issue clarifications and interpretations of the Contract Documents as provided herein.

3.02 *Reference Standards*

- A. Standards Specifications, Codes, Laws and Regulations
 - 1. Reference in the Contract Documents to standard specifications, manuals, reference standards, or codes of any technical society, organization, or association, or to Laws or Regulations, whether such reference be specific or by implication, shall mean the standard specification, manual, reference standard, code, or Laws or Regulations in effect at the time of opening of Bids (or on the Effective Date of the Contract if there were no Bids), except as may be otherwise specifically stated in the Contract Documents.
 - 2. No provision of any such standard specification, manual, reference standard, or code, or any instruction of a Supplier, shall be effective to change the duties or responsibilities of Owner, Contractor, or Engineer, or any of their subcontractors, consultants, agents, or employees, from those set forth in the part of the Contract Documents prepared by or for Engineer. No such provision or instruction shall be effective to assign to Owner, Engineer, or any of their officers, directors, members, partners, employees, agents, consultants, or subcontractors, any duty or authority to supervise or direct the performance of the Work or any duty or authority to undertake responsibility inconsistent with the provisions of the part of the Contract Documents prepared by or for Engineer.

3.03 *Reporting and Resolving Discrepancies*

- A. *Reporting Discrepancies:*
 - 1. *Contractor's Verification of Figures and Field Measurements:* Before undertaking each part of the Work, Contractor shall carefully study the Contract Documents, and check and verify pertinent figures and dimensions therein, particularly with respect to applicable field measurements. Contractor shall promptly report in writing to Engineer any conflict, error, ambiguity, or discrepancy that Contractor discovers, or has actual knowledge of, and shall not proceed with any Work affected thereby until the conflict,

error, ambiguity, or discrepancy is resolved, by a clarification or interpretation by Engineer, or by an amendment or supplement to the Contract Documents issued pursuant to Paragraph 11.01.

2. *Contractor's Review of Contract Documents:* If, before or during the performance of the Work, Contractor discovers any conflict, error, ambiguity, or discrepancy within the Contract Documents, or between the Contract Documents and (a) any applicable Law or Regulation, (b) actual field conditions, (c) any standard specification, manual, reference standard, or code, or (d) any instruction of any Supplier, then Contractor shall promptly report it to Engineer in writing. Contractor shall not proceed with the Work affected thereby (except in an emergency as required by Paragraph 7.15) until the conflict, error, ambiguity, or discrepancy is resolved, by a clarification or interpretation by Engineer, or by an amendment or supplement to the Contract Documents issued pursuant to Paragraph 11.01.
3. Contractor shall not be liable to Owner or Engineer for failure to report any conflict, error, ambiguity, or discrepancy in the Contract Documents unless Contractor had actual knowledge thereof.

B. *Resolving Discrepancies:*

1. Except as may be otherwise specifically stated in the Contract Documents, the provisions of the part of the Contract Documents prepared by or for Engineer shall take precedence in resolving any conflict, error, ambiguity, or discrepancy between such provisions of the Contract Documents and:
 - a. the provisions of any standard specification, manual, reference standard, or code, or the instruction of any Supplier (whether or not specifically incorporated by reference as a Contract Document); or
 - b. the provisions of any Laws or Regulations applicable to the performance of the Work (unless such an interpretation of the provisions of the Contract Documents would result in violation of such Law or Regulation).

3.04 *Requirements of the Contract Documents*

- A. During the performance of the Work and until final payment, Contractor and Owner shall submit to the Engineer all matters in question concerning the requirements of the Contract Documents (sometimes referred to as requests for information or interpretation—RFIs), or relating to the acceptability of the Work under the Contract Documents, as soon as possible after such matters arise. Engineer will be the initial interpreter of the requirements of the Contract Documents, and judge of the acceptability of the Work thereunder.
- B. Engineer will, with reasonable promptness, render a written clarification, interpretation, or decision on the issue submitted, or initiate an amendment or supplement to the Contract Documents. Engineer's written clarification, interpretation, or decision will be final and binding on Contractor, unless it appeals by submitting a Change Proposal, and on Owner, unless it appeals by filing a Claim.
- C. If a submitted matter in question concerns terms and conditions of the Contract Documents that do not involve (1) the performance or acceptability of the Work under the Contract Documents, (2) the design (as set forth in the Drawings, Specifications, or otherwise), or (3) other engineering or technical matters, then Engineer will promptly give written notice to Owner and Contractor that Engineer is unable to provide a decision or interpretation. If Owner and Contractor are unable to agree on resolution of such a matter in question, either party may pursue resolution as provided in Article 12.

3.05 *Reuse of Documents*

- A. Contractor and its Subcontractors and Suppliers shall not:
 - 1. have or acquire any title to or ownership rights in any of the Drawings, Specifications, or other documents (or copies of any thereof) prepared by or bearing the seal of Engineer or its consultants, including electronic media editions, or reuse any such Drawings, Specifications, other documents, or copies thereof on extensions of the Project or any other project without written consent of Owner and Engineer and specific written verification or adaptation by Engineer; or
 - 2. have or acquire any title or ownership rights in any other Contract Documents, reuse any such Contract Documents for any purpose without Owner's express written consent, or violate any copyrights pertaining to such Contract Documents.
- B. The prohibitions of this Paragraph 3.05 will survive final payment, or termination of the Contract. Nothing herein shall preclude Contractor from retaining copies of the Contract Documents for record purposes.

ARTICLE 4 – COMMENCEMENT AND PROGRESS OF THE WORK

4.01 *Commencement of Contract Times; Notice to Proceed*

- A. The Contract Times will commence to run on the thirtieth day after the Effective Date of the Contract or, if a Notice to Proceed is given, on the day indicated in the Notice to Proceed. A Notice to Proceed may be given at any time within 30 days after the Effective Date of the Contract. In no event will the Contract Times commence to run later than the sixtieth day after the day of Bid opening or the thirtieth day after the Effective Date of the Contract, whichever date is earlier.

4.02 *Starting the Work*

- A. Contractor shall start to perform the Work on the date when the Contract Times commence to run. No Work shall be done at the Site prior to such date.

4.03 *Reference Points*

- A. Owner shall provide engineering surveys to establish reference points for construction which in Engineer's judgment are necessary to enable Contractor to proceed with the Work. Contractor shall be responsible for laying out the Work, shall protect and preserve the established reference points and property monuments, and shall make no changes or relocations without the prior written approval of Owner. Contractor shall report to Engineer whenever any reference point or property monument is lost or destroyed or requires relocation because of necessary changes in grades or locations, and shall be responsible for the accurate replacement or relocation of such reference points or property monuments by professionally qualified personnel.

4.04 *Progress Schedule*

- A. Contractor shall adhere to the Progress Schedule established in accordance with Paragraph 2.05 as it may be adjusted from time to time as provided below.
 - 1. Contractor shall submit to Engineer for acceptance (to the extent indicated in Paragraph 2.05) proposed adjustments in the Progress Schedule that will not result in changing the Contract Times.

2. Proposed adjustments in the Progress Schedule that will change the Contract Times shall be submitted in accordance with the requirements of Article 11.
- B. Contractor shall carry on the Work and adhere to the Progress Schedule during all disputes or disagreements with Owner. No Work shall be delayed or postponed pending resolution of any disputes or disagreements, or during any appeal process, except as permitted by Paragraph 16.04, or as Owner and Contractor may otherwise agree in writing.

4.05 *Delays in Contractor's Progress*

- A. If Owner, Engineer, or anyone for whom Owner is responsible, delays, disrupts, or interferes with the performance or progress of the Work, then Contractor shall be entitled to an equitable adjustment in the Contract Times and Contract Price. Contractor's entitlement to an adjustment of the Contract Times is conditioned on such adjustment being essential to Contractor's ability to complete the Work within the Contract Times.
- B. Contractor shall not be entitled to an adjustment in Contract Price or Contract Times for delay, disruption, or interference caused by or within the control of Contractor. Delay, disruption, and interference attributable to and within the control of a Subcontractor or Supplier shall be deemed to be within the control of Contractor.
- C. If Contractor's performance or progress is delayed, disrupted, or interfered with by unanticipated causes not the fault of and beyond the control of Owner, Contractor, and those for which they are responsible, then Contractor shall be entitled to an equitable adjustment in Contract Times. Contractor's entitlement to an adjustment of the Contract Times is conditioned on such adjustment being essential to Contractor's ability to complete the Work within the Contract Times. Such an adjustment shall be Contractor's sole and exclusive remedy for the delays, disruption, and interference described in this paragraph. Causes of delay, disruption, or interference that may give rise to an adjustment in Contract Times under this paragraph include but are not limited to the following:
1. severe and unavoidable natural catastrophes such as fires, floods, epidemics, and earthquakes;
 2. abnormal weather conditions;
 3. acts or failures to act of utility owners (other than those performing other work at or adjacent to the Site by arrangement with the Owner, as contemplated in Article 8); and
 4. acts of war or terrorism.
- D. Delays, disruption, and interference to the performance or progress of the Work resulting from the existence of a differing subsurface or physical condition, an Underground Facility that was not shown or indicated by the Contract Documents, or not shown or indicated with reasonable accuracy, and those resulting from Hazardous Environmental Conditions, are governed by Article 5.
- E. Paragraph 8.03 governs delays, disruption, and interference to the performance or progress of the Work resulting from the performance of certain other work at or adjacent to the Site.
- F. Contractor shall not be entitled to an adjustment in Contract Price or Contract Times for any delay, disruption, or interference if such delay is concurrent with a delay, disruption, or interference caused by or within the control of Contractor.

- G. Contractor must submit any Change Proposal seeking an adjustment in Contract Price or Contract Times under this paragraph within 30 days of the commencement of the delaying, disrupting, or interfering event.

ARTICLE 5 – AVAILABILITY OF LANDS; SUBSURFACE AND PHYSICAL CONDITIONS; HAZARDOUS ENVIRONMENTAL CONDITIONS

5.01 Availability of Lands

- A. Owner shall furnish the Site. Owner shall notify Contractor of any encumbrances or restrictions not of general application but specifically related to use of the Site with which Contractor must comply in performing the Work.
- B. Upon reasonable written request, Owner shall furnish Contractor with a current statement of record legal title and legal description of the lands upon which permanent improvements are to be made and Owner's interest therein as necessary for giving notice of or filing a mechanic's or construction lien against such lands in accordance with applicable Laws and Regulations.
- C. Contractor shall provide for all additional lands and access thereto that may be required for temporary construction facilities or storage of materials and equipment.

5.02 Use of Site and Other Areas

A. Limitation on Use of Site and Other Areas:

- 1. Contractor shall confine construction equipment, temporary construction facilities, the storage of materials and equipment, and the operations of workers to the Site, adjacent areas that Contractor has arranged to use through construction easements or otherwise, and other adjacent areas permitted by Laws and Regulations, and shall not unreasonably encumber the Site and such other adjacent areas with construction equipment or other materials or equipment. Contractor shall assume full responsibility for (a) damage to the Site; (b) damage to any such other adjacent areas used for Contractor's operations; (c) damage to any other adjacent land or areas; and (d) for injuries and losses sustained by the owners or occupants of any such land or areas; provided that such damage or injuries result from the performance of the Work or from other actions or conduct of the Contractor or those for which Contractor is responsible.
- 2. If a damage or injury claim is made by the owner or occupant of any such land or area because of the performance of the Work, or because of other actions or conduct of the Contractor or those for which Contractor is responsible, Contractor shall (a) take immediate corrective or remedial action as required by Paragraph 7.12, or otherwise; (b) promptly attempt to settle the claim as to all parties through negotiations with such owner or occupant, or otherwise resolve the claim by arbitration or other dispute resolution proceeding, or at law; and (c) to the fullest extent permitted by Laws and Regulations, indemnify and hold harmless Owner and Engineer, and the officers, directors, members, partners, employees, agents, consultants and subcontractors of each and any of them from and against any such claim, and against all costs, losses, and damages (including but not limited to all fees and charges of engineers, architects, attorneys, and other professionals and all court or arbitration or other dispute resolution costs) arising out of or relating to any claim or action, legal or equitable, brought by any such owner or occupant against Owner, Engineer, or any other party indemnified hereunder to the extent caused directly or indirectly, in whole or in part

by, or based upon, Contractor's performance of the Work, or because of other actions or conduct of the Contractor or those for which Contractor is responsible.

- B. *Removal of Debris During Performance of the Work:* During the progress of the Work the Contractor shall keep the Site and other adjacent areas free from accumulations of waste materials, rubbish, and other debris. Removal and disposal of such waste materials, rubbish, and other debris shall conform to applicable Laws and Regulations.
- C. *Cleaning:* Prior to Substantial Completion of the Work Contractor shall clean the Site and the Work and make it ready for utilization by Owner. At the completion of the Work Contractor shall remove from the Site and adjacent areas all tools, appliances, construction equipment and machinery, and surplus materials and shall restore to original condition all property not designated for alteration by the Contract Documents.
- D. *Loading of Structures:* Contractor shall not load nor permit any part of any structure to be loaded in any manner that will endanger the structure, nor shall Contractor subject any part of the Work or adjacent structures or land to stresses or pressures that will endanger them.

5.03 *Subsurface and Physical Conditions*

- A. *Reports and Drawings:* The Supplementary Conditions identify:
 - 1. those reports known to Owner of explorations and tests of subsurface conditions at or adjacent to the Site;
 - 2. those drawings known to Owner of physical conditions relating to existing surface or subsurface structures at the Site (except Underground Facilities); and
 - 3. Technical Data contained in such reports and drawings.
- B. *Reliance by Contractor on Technical Data Authorized:* Contractor may rely upon the accuracy of the Technical Data expressly identified in the Supplementary Conditions with respect to such reports and drawings, but such reports and drawings are not Contract Documents. If no such express identification has been made, then Contractor may rely upon the accuracy of the Technical Data (as defined in Article 1) contained in any geotechnical or environmental report prepared for the Project and made available to Contractor. Except for such reliance on Technical Data, Contractor may not rely upon or make any claim against Owner or Engineer, or any of their officers, directors, members, partners, employees, agents, consultants, or subcontractors, with respect to:
 - 1. the completeness of such reports and drawings for Contractor's purposes, including, but not limited to, any aspects of the means, methods, techniques, sequences, and procedures of construction to be employed by Contractor, and safety precautions and programs incident thereto; or
 - 2. other data, interpretations, opinions, and information contained in such reports or shown or indicated in such drawings; or
 - 3. any Contractor interpretation of or conclusion drawn from any Technical Data or any such other data, interpretations, opinions, or information.

5.04 *Differing Subsurface or Physical Conditions*

- A. *Notice by Contractor:* If Contractor believes that any subsurface or physical condition that is uncovered or revealed at the Site either:
1. is of such a nature as to establish that any Technical Data on which Contractor is entitled to rely as provided in Paragraph 5.03 is materially inaccurate; or
 2. is of such a nature as to require a change in the Drawings or Specifications; or
 3. differs materially from that shown or indicated in the Contract Documents; or
 4. is of an unusual nature, and differs materially from conditions ordinarily encountered and generally recognized as inherent in work of the character provided for in the Contract Documents;

then Contractor shall, promptly after becoming aware thereof and before further disturbing the subsurface or physical conditions or performing any Work in connection therewith (except in an emergency as required by Paragraph 7.15), notify Owner and Engineer in writing about such condition. Contractor shall not further disturb such condition or perform any Work in connection therewith (except with respect to an emergency) until receipt of a written statement permitting Contractor to do so.

- B. *Engineer's Review:* After receipt of written notice as required by the preceding paragraph, Engineer will promptly review the subsurface or physical condition in question; determine the necessity of Owner's obtaining additional exploration or tests with respect to the condition; conclude whether the condition falls within any one or more of the differing site condition categories in Paragraph 5.04.A above; obtain any pertinent cost or schedule information from Contractor; prepare recommendations to Owner regarding the Contractor's resumption of Work in connection with the subsurface or physical condition in question and the need for any change in the Drawings or Specifications; and advise Owner in writing of Engineer's findings, conclusions, and recommendations.
- C. *Owner's Statement to Contractor Regarding Site Condition:* After receipt of Engineer's written findings, conclusions, and recommendations, Owner shall issue a written statement to Contractor (with a copy to Engineer) regarding the subsurface or physical condition in question, addressing the resumption of Work in connection with such condition, indicating whether any change in the Drawings or Specifications will be made, and adopting or rejecting Engineer's written findings, conclusions, and recommendations, in whole or in part.
- D. *Possible Price and Times Adjustments:*
1. Contractor shall be entitled to an equitable adjustment in Contract Price or Contract Times, or both, to the extent that the existence of a differing subsurface or physical condition, or any related delay, disruption, or interference, causes an increase or decrease in Contractor's cost of, or time required for, performance of the Work; subject, however, to the following:
 - a. such condition must fall within any one or more of the categories described in Paragraph 5.04.A;
 - b. with respect to Work that is paid for on a unit price basis, any adjustment in Contract Price will be subject to the provisions of Paragraph 13.03; and,

- c. Contractor's entitlement to an adjustment of the Contract Times is conditioned on such adjustment being essential to Contractor's ability to complete the Work within the Contract Times.
2. Contractor shall not be entitled to any adjustment in the Contract Price or Contract Times with respect to a subsurface or physical condition if:
 - a. Contractor knew of the existence of such condition at the time Contractor made a commitment to Owner with respect to Contract Price and Contract Times by the submission of a Bid or becoming bound under a negotiated contract, or otherwise; or
 - b. the existence of such condition reasonably could have been discovered or revealed as a result of any examination, investigation, exploration, test, or study of the Site and contiguous areas expressly required by the Bidding Requirements or Contract Documents to be conducted by or for Contractor prior to Contractor's making such commitment; or
 - c. Contractor failed to give the written notice as required by Paragraph 5.04.A.
 3. If Owner and Contractor agree regarding Contractor's entitlement to and the amount or extent of any adjustment in the Contract Price or Contract Times, or both, then any such adjustment shall be set forth in a Change Order.
 4. Contractor may submit a Change Proposal regarding its entitlement to or the amount or extent of any adjustment in the Contract Price or Contract Times, or both, no later than 30 days after Owner's issuance of the Owner's written statement to Contractor regarding the subsurface or physical condition in question.

5.05 *Underground Facilities*

- A. *Contractor's Responsibilities:* The information and data shown or indicated in the Contract Documents with respect to existing Underground Facilities at or adjacent to the Site is based on information and data furnished to Owner or Engineer by the owners of such Underground Facilities, including Owner, or by others. Unless it is otherwise expressly provided in the Supplementary Conditions:
 1. Owner and Engineer do not warrant or guarantee the accuracy or completeness of any such information or data provided by others; and
 2. the cost of all of the following will be included in the Contract Price, and Contractor shall have full responsibility for:
 - a. reviewing and checking all information and data regarding existing Underground Facilities at the Site;
 - b. locating all Underground Facilities shown or indicated in the Contract Documents as being at the Site;
 - c. coordination of the Work with the owners (including Owner) of such Underground Facilities, during construction; and
 - d. the safety and protection of all existing Underground Facilities at the Site, and repairing any damage thereto resulting from the Work.
- B. *Notice by Contractor:* If Contractor believes that an Underground Facility that is uncovered or revealed at the Site was not shown or indicated in the Contract Documents, or was not shown or indicated with reasonable accuracy, then Contractor shall, promptly after

becoming aware thereof and before further disturbing conditions affected thereby or performing any Work in connection therewith (except in an emergency as required by Paragraph 7.15), identify the owner of such Underground Facility and give written notice to that owner and to Owner and Engineer.

- C. *Engineer's Review:* Engineer will promptly review the Underground Facility and conclude whether such Underground Facility was not shown or indicated in the Contract Documents, or was not shown or indicated with reasonable accuracy; obtain any pertinent cost or schedule information from Contractor; prepare recommendations to Owner regarding the Contractor's resumption of Work in connection with the Underground Facility in question; determine the extent, if any, to which a change is required in the Drawings or Specifications to reflect and document the consequences of the existence or location of the Underground Facility; and advise Owner in writing of Engineer's findings, conclusions, and recommendations. During such time, Contractor shall be responsible for the safety and protection of such Underground Facility.
- D. *Owner's Statement to Contractor Regarding Underground Facility:* After receipt of Engineer's written findings, conclusions, and recommendations, Owner shall issue a written statement to Contractor (with a copy to Engineer) regarding the Underground Facility in question, addressing the resumption of Work in connection with such Underground Facility, indicating whether any change in the Drawings or Specifications will be made, and adopting or rejecting Engineer's written findings, conclusions, and recommendations in whole or in part.
- E. *Possible Price and Times Adjustments:*
 - 1. Contractor shall be entitled to an equitable adjustment in the Contract Price or Contract Times, or both, to the extent that any existing Underground Facility at the Site that was not shown or indicated in the Contract Documents, or was not shown or indicated with reasonable accuracy, or any related delay, disruption, or interference, causes an increase or decrease in Contractor's cost of, or time required for, performance of the Work; subject, however, to the following:
 - a. Contractor did not know of and could not reasonably have been expected to be aware of or to have anticipated the existence or actual location of the Underground Facility in question;
 - b. With respect to Work that is paid for on a unit price basis, any adjustment in Contract Price will be subject to the provisions of Paragraph 13.03;
 - c. Contractor's entitlement to an adjustment of the Contract Times is conditioned on such adjustment being essential to Contractor's ability to complete the Work within the Contract Times; and
 - d. Contractor gave the notice required in Paragraph 5.05.B.
 - 2. If Owner and Contractor agree regarding Contractor's entitlement to and the amount or extent of any adjustment in the Contract Price or Contract Times, or both, then any such adjustment shall be set forth in a Change Order.
 - 3. Contractor may submit a Change Proposal regarding its entitlement to or the amount or extent of any adjustment in the Contract Price or Contract Times, or both, no later than 30 days after Owner's issuance of the Owner's written statement to Contractor regarding the Underground Facility in question.

5.06 *Hazardous Environmental Conditions at Site*

- A. *Reports and Drawings*: The Supplementary Conditions identify:
1. those reports and drawings known to Owner relating to Hazardous Environmental Conditions that have been identified at or adjacent to the Site; and
 2. Technical Data contained in such reports and drawings.
- B. *Reliance by Contractor on Technical Data Authorized*: Contractor may rely upon the accuracy of the Technical Data expressly identified in the Supplementary Conditions with respect to such reports and drawings, but such reports and drawings are not Contract Documents. If no such express identification has been made, then Contractor may rely on the accuracy of the Technical Data (as defined in Article 1) contained in any geotechnical or environmental report prepared for the Project and made available to Contractor. Except for such reliance on Technical Data, Contractor may not rely upon or make any claim against Owner or Engineer, or any of their officers, directors, members, partners, employees, agents, consultants, or subcontractors with respect to:
1. the completeness of such reports and drawings for Contractor's purposes, including, but not limited to, any aspects of the means, methods, techniques, sequences and procedures of construction to be employed by Contractor and safety precautions and programs incident thereto; or
 2. other data, interpretations, opinions and information contained in such reports or shown or indicated in such drawings; or
 3. any Contractor interpretation of or conclusion drawn from any Technical Data or any such other data, interpretations, opinions or information.
- C. Contractor shall not be responsible for removing or remediating any Hazardous Environmental Condition encountered, uncovered, or revealed at the Site unless such removal or remediation is expressly identified in the Contract Documents to be within the scope of the Work.
- D. Contractor shall be responsible for controlling, containing, and duly removing all Constituents of Concern brought to the Site by Contractor, Subcontractors, Suppliers, or anyone else for whom Contractor is responsible, and for any associated costs; and for the costs of removing and remediating any Hazardous Environmental Condition created by the presence of any such Constituents of Concern.
- E. If Contractor encounters, uncovers, or reveals a Hazardous Environmental Condition whose removal or remediation is not expressly identified in the Contract Documents as being within the scope of the Work, or if Contractor or anyone for whom Contractor is responsible creates a Hazardous Environmental Condition, then Contractor shall immediately: (1) secure or otherwise isolate such condition; (2) stop all Work in connection with such condition and in any area affected thereby (except in an emergency as required by Paragraph 7.15); and (3) notify Owner and Engineer (and promptly thereafter confirm such notice in writing). Owner shall promptly consult with Engineer concerning the necessity for Owner to retain a qualified expert to evaluate such condition or take corrective action, if any. Promptly after consulting with Engineer, Owner shall take such actions as are necessary to permit Owner to timely obtain required permits and provide Contractor the written notice required by Paragraph 5.06.F. If Contractor or anyone for whom Contractor is responsible created the Hazardous Environmental Condition in question, then Owner may remove and remediate the Hazardous Environmental Condition, and impose a set-off against payments to account for the associated costs.

- F. Contractor shall not resume Work in connection with such Hazardous Environmental Condition or in any affected area until after Owner has obtained any required permits related thereto, and delivered written notice to Contractor either (1) specifying that such condition and any affected area is or has been rendered safe for the resumption of Work, or (2) specifying any special conditions under which such Work may be resumed safely.
- G. If Owner and Contractor cannot agree as to entitlement to or on the amount or extent, if any, of any adjustment in Contract Price or Contract Times, or both, as a result of such Work stoppage or such special conditions under which Work is agreed to be resumed by Contractor, then within 30 days of Owner's written notice regarding the resumption of Work, Contractor may submit a Change Proposal, or Owner may impose a set-off.
- H. If after receipt of such written notice Contractor does not agree to resume such Work based on a reasonable belief it is unsafe, or does not agree to resume such Work under such special conditions, then Owner may order the portion of the Work that is in the area affected by such condition to be deleted from the Work, following the contractual change procedures in Article 11. Owner may have such deleted portion of the Work performed by Owner's own forces or others in accordance with Article 8.
- I. To the fullest extent permitted by Laws and Regulations, Owner shall indemnify and hold harmless Contractor, Subcontractors, and Engineer, and the officers, directors, members, partners, employees, agents, consultants, and subcontractors of each and any of them from and against all claims, costs, losses, and damages (including but not limited to all fees and charges of engineers, architects, attorneys, and other professionals and all court or arbitration or other dispute resolution costs) arising out of or relating to a Hazardous Environmental Condition, provided that such Hazardous Environmental Condition (1) was not shown or indicated in the Drawings, Specifications, or other Contract Documents, identified as Technical Data entitled to limited reliance pursuant to Paragraph 5.06.B, or identified in the Contract Documents to be included within the scope of the Work, and (2) was not created by Contractor or by anyone for whom Contractor is responsible. Nothing in this Paragraph 5.06.I shall obligate Owner to indemnify any individual or entity from and against the consequences of that individual's or entity's own negligence.
- J. To the fullest extent permitted by Laws and Regulations, Contractor shall indemnify and hold harmless Owner and Engineer, and the officers, directors, members, partners, employees, agents, consultants, and subcontractors of each and any of them from and against all claims, costs, losses, and damages (including but not limited to all fees and charges of engineers, architects, attorneys, and other professionals and all court or arbitration or other dispute resolution costs) arising out of or relating to the failure to control, contain, or remove a Constituent of Concern brought to the Site by Contractor or by anyone for whom Contractor is responsible, or to a Hazardous Environmental Condition created by Contractor or by anyone for whom Contractor is responsible. Nothing in this Paragraph 5.06.J shall obligate Contractor to indemnify any individual or entity from and against the consequences of that individual's or entity's own negligence.
- K. The provisions of Paragraphs 5.03, 5.04, and 5.05 do not apply to the presence of Constituents of Concern or to a Hazardous Environmental Condition uncovered or revealed at the Site.

ARTICLE 6 – BONDS AND INSURANCE

6.01 *Performance, Payment, and Other Bonds*

- A. Contractor shall furnish a performance bond and a payment bond, each in an amount at least equal to the Contract Price, as security for the faithful performance and payment of all of Contractor's obligations under the Contract. These bonds shall remain in effect until one year after the date when final payment becomes due or until completion of the correction period specified in Paragraph 15.08, whichever is later, except as provided otherwise by Laws or Regulations, the Supplementary Conditions, or other specific provisions of the Contract. Contractor shall also furnish such other bonds as are required by the Supplementary Conditions or other specific provisions of the Contract.
- B. All bonds shall be in the form prescribed by the Contract except as provided otherwise by Laws or Regulations, and shall be executed by such sureties as are named in "Companies Holding Certificates of Authority as Acceptable Sureties on Federal Bonds and as Acceptable Reinsuring Companies" as published in Circular 570 (as amended and supplemented) by the Financial Management Service, Surety Bond Branch, U.S. Department of the Treasury. A bond signed by an agent or attorney-in-fact must be accompanied by a certified copy of that individual's authority to bind the surety. The evidence of authority shall show that it is effective on the date the agent or attorney-in-fact signed the accompanying bond.
- C. Contractor shall obtain the required bonds from surety companies that are duly licensed or authorized in the jurisdiction in which the Project is located to issue bonds in the required amounts.
- D. If the surety on a bond furnished by Contractor is declared bankrupt or becomes insolvent, or its right to do business is terminated in any state or jurisdiction where any part of the Project is located, or the surety ceases to meet the requirements above, then Contractor shall promptly notify Owner and Engineer and shall, within 20 days after the event giving rise to such notification, provide another bond and surety, both of which shall comply with the bond and surety requirements above.
- E. If Contractor has failed to obtain a required bond, Owner may exclude the Contractor from the Site and exercise Owner's termination rights under Article 16.
- F. Upon request, Owner shall provide a copy of the payment bond to any Subcontractor, Supplier, or other person or entity claiming to have furnished labor or materials used in the performance of the Work.

6.02 *Insurance—General Provisions*

- A. Owner and Contractor shall obtain and maintain insurance as required in this Article and in the Supplementary Conditions.
- B. All insurance required by the Contract to be purchased and maintained by Owner or Contractor shall be obtained from insurance companies that are duly licensed or authorized, in the state or jurisdiction in which the Project is located, to issue insurance policies for the required limits and coverages. Unless a different standard is indicated in the Supplementary Conditions, all companies that provide insurance policies required under this Contract shall have an A.M. Best rating of A-VII or better.
- C. Contractor shall deliver to Owner, with copies to each named insured and additional insured (as identified in this Article, in the Supplementary Conditions, or elsewhere in the Contract), certificates of insurance establishing that Contractor has obtained and is

maintaining the policies, coverages, and endorsements required by the Contract. Upon request by Owner or any other insured, Contractor shall also furnish other evidence of such required insurance, including but not limited to copies of policies and endorsements, and documentation of applicable self-insured retentions and deductibles. Contractor may block out (redact) any confidential premium or pricing information contained in any policy or endorsement furnished under this provision.

- D. Owner shall deliver to Contractor, with copies to each named insured and additional insured (as identified in this Article, the Supplementary Conditions, or elsewhere in the Contract), certificates of insurance establishing that Owner has obtained and is maintaining the policies, coverages, and endorsements required of Owner by the Contract (if any). Upon request by Contractor or any other insured, Owner shall also provide other evidence of such required insurance (if any), including but not limited to copies of policies and endorsements, and documentation of applicable self-insured retentions and deductibles. Owner may block out (redact) any confidential premium or pricing information contained in any policy or endorsement furnished under this provision.
- E. Failure of Owner or Contractor to demand such certificates or other evidence of the other party's full compliance with these insurance requirements, or failure of Owner or Contractor to identify a deficiency in compliance from the evidence provided, shall not be construed as a waiver of the other party's obligation to obtain and maintain such insurance.
- F. If either party does not purchase or maintain all of the insurance required of such party by the Contract, such party shall notify the other party in writing of such failure to purchase prior to the start of the Work, or of such failure to maintain prior to any change in the required coverage.
- G. If Contractor has failed to obtain and maintain required insurance, Owner may exclude the Contractor from the Site, impose an appropriate set-off against payment, and exercise Owner's termination rights under Article 16.
- H. Without prejudice to any other right or remedy, if a party has failed to obtain required insurance, the other party may elect to obtain equivalent insurance to protect such other party's interests at the expense of the party who was required to provide such coverage, and the Contract Price shall be adjusted accordingly.
- I. Owner does not represent that insurance coverage and limits established in this Contract necessarily will be adequate to protect Contractor or Contractor's interests.
- J. The insurance and insurance limits required herein shall not be deemed as a limitation on Contractor's liability under the indemnities granted to Owner and other individuals and entities in the Contract.

6.03 *Contractor's Insurance*

- A. *Workers' Compensation:* Contractor shall purchase and maintain workers' compensation and employer's liability insurance for:
 - 1. claims under workers' compensation, disability benefits, and other similar employee benefit acts.
 - 2. United States Longshoreman and Harbor Workers' Compensation Act and Jones Act coverage (if applicable).
 - 3. claims for damages because of bodily injury, occupational sickness or disease, or death of Contractor's employees (by stop-gap endorsement in monopolist worker's compensation states).

4. Foreign voluntary worker compensation (if applicable).
- B. *Commercial General Liability—Claims Covered:* Contractor shall purchase and maintain commercial general liability insurance, covering all operations by or on behalf of Contractor, on an occurrence basis, against:
1. claims for damages because of bodily injury, sickness or disease, or death of any person other than Contractor's employees.
 2. claims for damages insured by reasonably available personal injury liability coverage.
 3. claims for damages, other than to the Work itself, because of injury to or destruction of tangible property wherever located, including loss of use resulting therefrom.
- C. *Commercial General Liability—Form and Content:* Contractor's commercial liability policy shall be written on a 1996 (or later) ISO commercial general liability form (occurrence form) and include the following coverages and endorsements:
1. Products and completed operations coverage:
 - a. Such insurance shall be maintained for three years after final payment.
 - b. Contractor shall furnish Owner and each other additional insured (as identified in the Supplementary Conditions or elsewhere in the Contract) evidence of continuation of such insurance at final payment and three years thereafter.
 2. Blanket contractual liability coverage, to the extent permitted by law, including but not limited to coverage of Contractor's contractual indemnity obligations in Paragraph 7.18.
 3. Broad form property damage coverage.
 4. Severability of interest.
 5. Underground, explosion, and collapse coverage.
 6. Personal injury coverage.
 7. Additional insured endorsements that include both ongoing operations and products and completed operations coverage through ISO Endorsements CG 20 10 10 01 and CG 20 37 10 01 (together); or CG 20 10 07 04 and CG 20 37 07 04 (together); or their equivalent.
 8. For design professional additional insureds, ISO Endorsement CG 20 32 07 04, "Additional Insured—Engineers, Architects or Surveyors Not Engaged by the Named Insured" or its equivalent.
- D. *Automobile liability:* Contractor shall purchase and maintain automobile liability insurance against claims for damages because of bodily injury or death of any person or property damage arising out of the ownership, maintenance, or use of any motor vehicle. The automobile liability policy shall be written on an occurrence basis.
- E. *Umbrella or excess liability:* Contractor shall purchase and maintain umbrella or excess liability insurance written over the underlying employer's liability, commercial general liability, and automobile liability insurance described in the paragraphs above. Subject to industry-standard exclusions, the coverage afforded shall follow form as to each and every one of the underlying policies.
- F. *Contractor's pollution liability insurance:* Contractor shall purchase and maintain a policy covering third-party injury and property damage claims, including clean-up costs, as a result

of pollution conditions arising from Contractor's operations and completed operations. This insurance shall be maintained for no less than three years after final completion.

- G. *Additional insureds*: The Contractor's commercial general liability, automobile liability, umbrella or excess, and pollution liability policies shall include and list as additional insureds Owner and Engineer, and any individuals or entities identified in the Supplementary Conditions; include coverage for the respective officers, directors, members, partners, employees, agents, consultants, and subcontractors of each and any of all such additional insureds; and the insurance afforded to these additional insureds shall provide primary coverage for all claims covered thereby (including as applicable those arising from both ongoing and completed operations) on a non-contributory basis. Contractor shall obtain all necessary endorsements to support these requirements.
- H. *Contractor's professional liability insurance*: If Contractor will provide or furnish professional services under this Contract, through a delegation of professional design services or otherwise, then Contractor shall be responsible for purchasing and maintaining applicable professional liability insurance. This insurance shall provide protection against claims arising out of performance of professional design or related services, and caused by a negligent error, omission, or act for which the insured party is legally liable. It shall be maintained throughout the duration of the Contract and for a minimum of two years after Substantial Completion. If such professional design services are performed by a Subcontractor, and not by Contractor itself, then the requirements of this paragraph may be satisfied through the purchasing and maintenance of such insurance by such Subcontractor.
- I. *General provisions*: The policies of insurance required by this Paragraph 6.03 shall:
1. include at least the specific coverages provided in this Article.
 2. be written for not less than the limits of liability provided in this Article and in the Supplementary Conditions, or required by Laws or Regulations, whichever is greater.
 3. contain a provision or endorsement that the coverage afforded will not be canceled, materially changed, or renewal refused until at least 10 days prior written notice has been given to Contractor. Within three days of receipt of any such written notice, Contractor shall provide a copy of the notice to Owner, Engineer, and each other insured under the policy.
 4. remain in effect at least until final payment (and longer if expressly required in this Article) and at all times thereafter when Contractor may be correcting, removing, or replacing defective Work as a warranty or correction obligation, or otherwise, or returning to the Site to conduct other tasks arising from the Contract Documents.
 5. be appropriate for the Work being performed and provide protection from claims that may arise out of or result from Contractor's performance of the Work and Contractor's other obligations under the Contract Documents, whether it is to be performed by Contractor, any Subcontractor or Supplier, or by anyone directly or indirectly employed by any of them to perform any of the Work, or by anyone for whose acts any of them may be liable.
- J. The coverage requirements for specific policies of insurance must be met by such policies, and not by reference to excess or umbrella insurance provided in other policies.

6.04 *Owner's Liability Insurance*

- A. In addition to the insurance required to be provided by Contractor under Paragraph 6.03, Owner, at Owner's option, may purchase and maintain at Owner's expense Owner's own liability insurance as will protect Owner against claims which may arise from operations under the Contract Documents.
- B. Owner's liability policies, if any, operate separately and independently from policies required to be provided by Contractor, and Contractor cannot rely upon Owner's liability policies for any of Contractor's obligations to the Owner, Engineer, or third parties.

6.05 *Property Insurance*

- A. *Builder's Risk*: Unless otherwise provided in the Supplementary Conditions, Contractor shall purchase and maintain builder's risk insurance upon the Work on a completed value basis, in the amount of the full insurable replacement cost thereof (subject to such deductible amounts as may be provided in the Supplementary Conditions or required by Laws and Regulations). This insurance shall:
 - 1. include the Owner and Contractor as named insureds, and all Subcontractors, and any individuals or entities required by the Supplementary Conditions to be insured under such builder's risk policy, as insureds or named insureds. For purposes of the remainder of this Paragraph 6.05, Paragraphs 6.06 and 6.07, and any corresponding Supplementary Conditions, the parties required to be insured shall collectively be referred to as "insureds."
 - 2. be written on a builder's risk "all risk" policy form that shall at least include insurance for physical loss or damage to the Work, temporary buildings, falsework, and materials and equipment in transit, and shall insure against at least the following perils or causes of loss: fire; lightning; windstorm; riot; civil commotion; terrorism; vehicle impact; aircraft; smoke; theft; vandalism and malicious mischief; mechanical breakdown, boiler explosion, and artificially generated electric current; earthquake; volcanic activity, and other earth movement; flood; collapse; explosion; debris removal; demolition occasioned by enforcement of Laws and Regulations; water damage (other than that caused by flood); and such other perils or causes of loss as may be specifically required by the Supplementary Conditions. If insurance against mechanical breakdown, boiler explosion, and artificially generated electric current; earthquake; volcanic activity, and other earth movement; or flood, are not commercially available under builder's risk policies, by endorsement or otherwise, such insurance may be provided through other insurance policies acceptable to Owner and Contractor.
 - 3. cover, as insured property, at least the following: (a) the Work and all materials, supplies, machinery, apparatus, equipment, fixtures, and other property of a similar nature that are to be incorporated into or used in the preparation, fabrication, construction, erection, or completion of the Work, including Owner-furnished or assigned property; (b) spare parts inventory required within the scope of the Contract; and (c) temporary works which are not intended to form part of the permanent constructed Work but which are intended to provide working access to the Site, or to the Work under construction, or which are intended to provide temporary support for the Work under construction, including scaffolding, form work, fences, shoring, falsework, and temporary structures.
 - 4. cover expenses incurred in the repair or replacement of any insured property (including but not limited to fees and charges of engineers and architects).

5. extend to cover damage or loss to insured property while in temporary storage at the Site or in a storage location outside the Site (but not including property stored at the premises of a manufacturer or Supplier).
 6. extend to cover damage or loss to insured property while in transit.
 7. allow for partial occupation or use of the Work by Owner, such that those portions of the Work that are not yet occupied or used by Owner shall remain covered by the builder's risk insurance.
 8. allow for the waiver of the insurer's subrogation rights, as set forth below.
 9. provide primary coverage for all losses and damages caused by the perils or causes of loss covered.
 10. not include a co-insurance clause.
 11. include an exception for ensuing losses from physical damage or loss with respect to any defective workmanship, design, or materials exclusions.
 12. include performance/hot testing and start-up.
 13. be maintained in effect, subject to the provisions herein regarding Substantial Completion and partial occupancy or use of the Work by Owner, until the Work is complete.
- B. *Notice of Cancellation or Change:* All the policies of insurance (and the certificates or other evidence thereof) required to be purchased and maintained in accordance with this Paragraph 6.05 will contain a provision or endorsement that the coverage afforded will not be canceled or materially changed or renewal refused until at least 10 days prior written notice has been given to the purchasing policyholder. Within three days of receipt of any such written notice, the purchasing policyholder shall provide a copy of the notice to each other insured.
- C. *Deductibles:* The purchaser of any required builder's risk or property insurance shall pay for costs not covered because of the application of a policy deductible.
- D. *Partial Occupancy or Use by Owner:* If Owner will occupy or use a portion or portions of the Work prior to Substantial Completion of all the Work as provided in Paragraph 15.04, then Owner (directly, if it is the purchaser of the builder's risk policy, or through Contractor) will provide notice of such occupancy or use to the builder's risk insurer. The builder's risk insurance shall not be canceled or permitted to lapse on account of any such partial use or occupancy; rather, those portions of the Work that are occupied or used by Owner may come off the builder's risk policy, while those portions of the Work not yet occupied or used by Owner shall remain covered by the builder's risk insurance.
- E. *Additional Insurance:* If Contractor elects to obtain other special insurance to be included in or supplement the builder's risk or property insurance policies provided under this Paragraph 6.05, it may do so at Contractor's expense.
- F. *Insurance of Other Property:* If the express insurance provisions of the Contract do not require or address the insurance of a property item or interest, such as tools, construction equipment, or other personal property owned by Contractor, a Subcontractor, or an employee of Contractor or a Subcontractor, then the entity or individual owning such property item will be responsible for deciding whether to insure it, and if so in what amount.

6.06 *Waiver of Rights*

- A. All policies purchased in accordance with Paragraph 6.05, expressly including the builder's risk policy, shall contain provisions to the effect that in the event of payment of any loss or damage the insurers will have no rights of recovery against any insureds thereunder, or against Engineer or its consultants, or their officers, directors, members, partners, employees, agents, consultants, or subcontractors. Owner and Contractor waive all rights against each other and the respective officers, directors, members, partners, employees, agents, consultants, and subcontractors of each and any of them, for all losses and damages caused by, arising out of, or resulting from any of the perils or causes of loss covered by such policies and any other property insurance applicable to the Work; and, in addition, waive all such rights against Engineer, its consultants, all Subcontractors, all individuals or entities identified in the Supplementary Conditions as insureds, and the officers, directors, members, partners, employees, agents, consultants, and subcontractors of each and any of them, under such policies for losses and damages so caused. None of the above waivers shall extend to the rights that any party making such waiver may have to the proceeds of insurance held by Owner or Contractor as trustee or fiduciary, or otherwise payable under any policy so issued.
- B. Owner waives all rights against Contractor, Subcontractors, and Engineer, and the officers, directors, members, partners, employees, agents, consultants and subcontractors of each and any of them, for:
 - 1. loss due to business interruption, loss of use, or other consequential loss extending beyond direct physical loss or damage to Owner's property or the Work caused by, arising out of, or resulting from fire or other perils whether or not insured by Owner; and
 - 2. loss or damage to the completed Project or part thereof caused by, arising out of, or resulting from fire or other insured peril or cause of loss covered by any property insurance maintained on the completed Project or part thereof by Owner during partial occupancy or use pursuant to Paragraph 15.04, after Substantial Completion pursuant to Paragraph 15.03, or after final payment pursuant to Paragraph 15.06.
- C. Any insurance policy maintained by Owner covering any loss, damage or consequential loss referred to in Paragraph 6.06.B shall contain provisions to the effect that in the event of payment of any such loss, damage, or consequential loss, the insurers will have no rights of recovery against Contractor, Subcontractors, or Engineer, or the officers, directors, members, partners, employees, agents, consultants, or subcontractors of each and any of them.
- D. Contractor shall be responsible for assuring that the agreement under which a Subcontractor performs a portion of the Work contains provisions whereby the Subcontractor waives all rights against Owner, Contractor, all individuals or entities identified in the Supplementary Conditions as insureds, the Engineer and its consultants, and the officers, directors, members, partners, employees, agents, consultants, and subcontractors of each and any of them, for all losses and damages caused by, arising out of, relating to, or resulting from any of the perils or causes of loss covered by builder's risk insurance and any other property insurance applicable to the Work.

6.07 *Receipt and Application of Property Insurance Proceeds*

- A. Any insured loss under the builder's risk and other policies of insurance required by Paragraph 6.05 will be adjusted and settled with the named insured that purchased the

policy. Such named insured shall act as fiduciary for the other insureds, and give notice to such other insureds that adjustment and settlement of a claim is in progress. Any other insured may state its position regarding a claim for insured loss in writing within 15 days after notice of such claim.

- B. Proceeds for such insured losses may be made payable by the insurer either jointly to multiple insureds, or to the named insured that purchased the policy in its own right and as fiduciary for other insureds, subject to the requirements of any applicable mortgage clause. A named insured receiving insurance proceeds under the builder's risk and other policies of insurance required by Paragraph 6.05 shall distribute such proceeds in accordance with such agreement as the parties in interest may reach, or as otherwise required under the dispute resolution provisions of this Contract or applicable Laws and Regulations.
- C. If no other special agreement is reached, the damaged Work shall be repaired or replaced, the money so received applied on account thereof, and the Work and the cost thereof covered by Change Order, if needed.

ARTICLE 7 – CONTRACTOR'S RESPONSIBILITIES

7.01 *Supervision and Superintendence*

- A. Contractor shall supervise, inspect, and direct the Work competently and efficiently, devoting such attention thereto and applying such skills and expertise as may be necessary to perform the Work in accordance with the Contract Documents. Contractor shall be solely responsible for the means, methods, techniques, sequences, and procedures of construction.
- B. At all times during the progress of the Work, Contractor shall assign a competent resident superintendent who shall not be replaced without written notice to Owner and Engineer except under extraordinary circumstances.

7.02 *Labor; Working Hours*

- A. Contractor shall provide competent, suitably qualified personnel to survey and lay out the Work and perform construction as required by the Contract Documents. Contractor shall at all times maintain good discipline and order at the Site.
- B. Except as otherwise required for the safety or protection of persons or the Work or property at the Site or adjacent thereto, and except as otherwise stated in the Contract Documents, all Work at the Site shall be performed during regular working hours, Monday through Friday. Contractor will not perform Work on a Saturday, Sunday, or any legal holiday. Contractor may perform Work outside regular working hours or on Saturdays, Sundays, or legal holidays only with Owner's written consent, which will not be unreasonably withheld.

7.03 *Services, Materials, and Equipment*

- A. Unless otherwise specified in the Contract Documents, Contractor shall provide and assume full responsibility for all services, materials, equipment, labor, transportation, construction equipment and machinery, tools, appliances, fuel, power, light, heat, telephone, water, sanitary facilities, temporary facilities, and all other facilities and incidentals necessary for the performance, testing, start up, and completion of the Work, whether or not such items are specifically called for in the Contract Documents.
- B. All materials and equipment incorporated into the Work shall be of good quality and new, except as otherwise provided in the Contract Documents. All special warranties and

guarantees required by the Specifications shall expressly run to the benefit of Owner. If required by Engineer, Contractor shall furnish satisfactory evidence (including reports of required tests) as to the source, kind, and quality of materials and equipment.

- C. All materials and equipment shall be stored, applied, installed, connected, erected, protected, used, cleaned, and conditioned in accordance with instructions of the applicable Supplier, except as otherwise may be provided in the Contract Documents.

7.04 "Or Equals"

- A. Whenever an item of material or equipment is specified or described in the Contract Documents by using the name of a proprietary item or the name of a particular Supplier, the Contract Price has been based upon Contractor furnishing such item as specified. The specification or description of such an item is intended to establish the type, function, appearance, and quality required. Unless the specification or description contains or is followed by words reading that no like, equivalent, or "or equal" item is permitted, Contractor may request that Engineer authorize the use of other items of material or equipment, or items from other proposed suppliers under the circumstances described below.
 - 1. If Engineer in its sole discretion determines that an item of material or equipment proposed by Contractor is functionally equal to that named and sufficiently similar so that no change in related Work will be required, Engineer shall deem it an "or equal" item. For the purposes of this paragraph, a proposed item of material or equipment will be considered functionally equal to an item so named if:
 - a. in the exercise of reasonable judgment Engineer determines that:
 - 1) it is at least equal in materials of construction, quality, durability, appearance, strength, and design characteristics;
 - 2) it will reliably perform at least equally well the function and achieve the results imposed by the design concept of the completed Project as a functioning whole;
 - 3) it has a proven record of performance and availability of responsive service; and
 - 4) it is not objectionable to Owner.
 - b. Contractor certifies that, if approved and incorporated into the Work:
 - 1) there will be no increase in cost to the Owner or increase in Contract Times; and
 - 2) it will conform substantially to the detailed requirements of the item named in the Contract Documents.
- B. *Contractor's Expense:* Contractor shall provide all data in support of any proposed "or equal" item at Contractor's expense.
- C. *Engineer's Evaluation and Determination:* Engineer will be allowed a reasonable time to evaluate each "or-equal" request. Engineer may require Contractor to furnish additional data about the proposed "or-equal" item. Engineer will be the sole judge of acceptability. No "or-equal" item will be ordered, furnished, installed, or utilized until Engineer's review is complete and Engineer determines that the proposed item is an "or-equal", which will be evidenced by an approved Shop Drawing or other written communication. Engineer will advise Contractor in writing of any negative determination.

- D. *Effect of Engineer's Determination:* Neither approval nor denial of an "or-equal" request shall result in any change in Contract Price. The Engineer's denial of an "or-equal" request shall be final and binding, and may not be reversed through an appeal under any provision of the Contract Documents.
- E. *Treatment as a Substitution Request:* If Engineer determines that an item of material or equipment proposed by Contractor does not qualify as an "or-equal" item, Contractor may request that Engineer consider the proposed item as a substitute pursuant to Paragraph 7.05.

7.05 *Substitutes*

- A. Unless the specification or description of an item of material or equipment required to be furnished under the Contract Documents contains or is followed by words reading that no substitution is permitted, Contractor may request that Engineer authorize the use of other items of material or equipment under the circumstances described below. To the extent possible such requests shall be made before commencement of related construction at the Site.
 - 1. Contractor shall submit sufficient information as provided below to allow Engineer to determine if the item of material or equipment proposed is functionally equivalent to that named and an acceptable substitute therefor. Engineer will not accept requests for review of proposed substitute items of material or equipment from anyone other than Contractor.
 - 2. The requirements for review by Engineer will be as set forth in Paragraph 7.05.B, as supplemented by the Specifications, and as Engineer may decide is appropriate under the circumstances.
 - 3. Contractor shall make written application to Engineer for review of a proposed substitute item of material or equipment that Contractor seeks to furnish or use. The application:
 - a. shall certify that the proposed substitute item will:
 - 1) perform adequately the functions and achieve the results called for by the general design,
 - 2) be similar in substance to that specified, and
 - 3) be suited to the same use as that specified.
 - b. will state:
 - 1) the extent, if any, to which the use of the proposed substitute item will necessitate a change in Contract Times,
 - 2) whether use of the proposed substitute item in the Work will require a change in any of the Contract Documents (or in the provisions of any other direct contract with Owner for other work on the Project) to adapt the design to the proposed substitute item, and
 - 3) whether incorporation or use of the proposed substitute item in connection with the Work is subject to payment of any license fee or royalty.
 - c. will identify:
 - 1) all variations of the proposed substitute item from that specified, and

- 2) available engineering, sales, maintenance, repair, and replacement services.
- d. shall contain an itemized estimate of all costs or credits that will result directly or indirectly from use of such substitute item, including but not limited to changes in Contract Price, shared savings, costs of redesign, and claims of other contractors affected by any resulting change.
- B. *Engineer's Evaluation and Determination:* Engineer will be allowed a reasonable time to evaluate each substitute request, and to obtain comments and direction from Owner. Engineer may require Contractor to furnish additional data about the proposed substitute item. Engineer will be the sole judge of acceptability. No substitute will be ordered, furnished, installed, or utilized until Engineer's review is complete and Engineer determines that the proposed item is an acceptable substitute. Engineer's determination will be evidenced by a Field Order or a proposed Change Order accounting for the substitution itself and all related impacts, including changes in Contract Price or Contract Times. Engineer will advise Contractor in writing of any negative determination.
- C. *Special Guarantee:* Owner may require Contractor to furnish at Contractor's expense a special performance guarantee or other surety with respect to any substitute.
- D. *Reimbursement of Engineer's Cost:* Engineer will record Engineer's costs in evaluating a substitute proposed or submitted by Contractor. Whether or not Engineer approves a substitute so proposed or submitted by Contractor, Contractor shall reimburse Owner for the reasonable charges of Engineer for evaluating each such proposed substitute. Contractor shall also reimburse Owner for the reasonable charges of Engineer for making changes in the Contract Documents (or in the provisions of any other direct contract with Owner) resulting from the acceptance of each proposed substitute.
- E. *Contractor's Expense:* Contractor shall provide all data in support of any proposed substitute at Contractor's expense.
- F. *Effect of Engineer's Determination:* If Engineer approves the substitution request, Contractor shall execute the proposed Change Order and proceed with the substitution. The Engineer's denial of a substitution request shall be final and binding, and may not be reversed through an appeal under any provision of the Contract Documents. Contractor may challenge the scope of reimbursement costs imposed under Paragraph 7.05.D, by timely submittal of a Change Proposal.

7.06 *Concerning Subcontractors, Suppliers, and Others*

- A. Contractor may retain Subcontractors and Suppliers for the performance of parts of the Work. Such Subcontractors and Suppliers must be acceptable to Owner.
- B. Contractor shall retain specific Subcontractors, Suppliers, or other individuals or entities for the performance of designated parts of the Work if required by the Contract to do so.
- C. Subsequent to the submittal of Contractor's Bid or final negotiation of the terms of the Contract, Owner may not require Contractor to retain any Subcontractor, Supplier, or other individual or entity to furnish or perform any of the Work against which Contractor has reasonable objection.
- D. Prior to entry into any binding subcontract or purchase order, Contractor shall submit to Owner the identity of the proposed Subcontractor or Supplier (unless Owner has already deemed such proposed Subcontractor or Supplier acceptable, during the bidding process or otherwise). Such proposed Subcontractor or Supplier shall be deemed acceptable to Owner unless Owner raises a substantive, reasonable objection within five days.

- E. Owner may require the replacement of any Subcontractor, Supplier, or other individual or entity retained by Contractor to perform any part of the Work. Owner also may require Contractor to retain specific replacements; provided, however, that Owner may not require a replacement to which Contractor has a reasonable objection. If Contractor has submitted the identity of certain Subcontractors, Suppliers, or other individuals or entities for acceptance by Owner, and Owner has accepted it (either in writing or by failing to make written objection thereto), then Owner may subsequently revoke the acceptance of any such Subcontractor, Supplier, or other individual or entity so identified solely on the basis of substantive, reasonable objection after due investigation. Contractor shall submit an acceptable replacement for the rejected Subcontractor, Supplier, or other individual or entity.
- F. If Owner requires the replacement of any Subcontractor, Supplier, or other individual or entity retained by Contractor to perform any part of the Work, then Contractor shall be entitled to an adjustment in Contract Price or Contract Times, or both, with respect to the replacement; and Contractor shall initiate a Change Proposal for such adjustment within 30 days of Owner's requirement of replacement.
- G. No acceptance by Owner of any such Subcontractor, Supplier, or other individual or entity, whether initially or as a replacement, shall constitute a waiver of the right of Owner to the completion of the Work in accordance with the Contract Documents.
- H. On a monthly basis Contractor shall submit to Engineer a complete list of all Subcontractors and Suppliers having a direct contract with Contractor, and of all other Subcontractors and Suppliers known to Contractor at the time of submittal.
- I. Contractor shall be fully responsible to Owner and Engineer for all acts and omissions of the Subcontractors, Suppliers, and other individuals or entities performing or furnishing any of the Work just as Contractor is responsible for Contractor's own acts and omissions.
- J. Contractor shall be solely responsible for scheduling and coordinating the work of Subcontractors, Suppliers, and all other individuals or entities performing or furnishing any of the Work.
- K. Contractor shall restrict all Subcontractors, Suppliers, and such other individuals or entities performing or furnishing any of the Work from communicating with Engineer or Owner, except through Contractor or in case of an emergency, or as otherwise expressly allowed herein.
- L. The divisions and sections of the Specifications and the identifications of any Drawings shall not control Contractor in dividing the Work among Subcontractors or Suppliers or delineating the Work to be performed by any specific trade.
- M. All Work performed for Contractor by a Subcontractor or Supplier shall be pursuant to an appropriate contractual agreement that specifically binds the Subcontractor or Supplier to the applicable terms and conditions of the Contract Documents for the benefit of Owner and Engineer.
- N. Owner may furnish to any Subcontractor or Supplier, to the extent practicable, information about amounts paid to Contractor on account of Work performed for Contractor by the particular Subcontractor or Supplier.

- O. Nothing in the Contract Documents:
1. shall create for the benefit of any such Subcontractor, Supplier, or other individual or entity any contractual relationship between Owner or Engineer and any such Subcontractor, Supplier, or other individual or entity; nor
 2. shall create any obligation on the part of Owner or Engineer to pay or to see to the payment of any money due any such Subcontractor, Supplier, or other individual or entity except as may otherwise be required by Laws and Regulations.

7.07 *Patent Fees and Royalties*

- A. Contractor shall pay all license fees and royalties and assume all costs incident to the use in the performance of the Work or the incorporation in the Work of any invention, design, process, product, or device which is the subject of patent rights or copyrights held by others. If a particular invention, design, process, product, or device is specified in the Contract Documents for use in the performance of the Work and if, to the actual knowledge of Owner or Engineer, its use is subject to patent rights or copyrights calling for the payment of any license fee or royalty to others, the existence of such rights shall be disclosed by Owner in the Contract Documents.
- B. To the fullest extent permitted by Laws and Regulations, Owner shall indemnify and hold harmless Contractor, and its officers, directors, members, partners, employees, agents, consultants, and subcontractors from and against all claims, costs, losses, and damages (including but not limited to all fees and charges of engineers, architects, attorneys, and other professionals, and all court or arbitration or other dispute resolution costs) arising out of or relating to any infringement of patent rights or copyrights incident to the use in the performance of the Work or resulting from the incorporation in the Work of any invention, design, process, product, or device specified in the Contract Documents, but not identified as being subject to payment of any license fee or royalty to others required by patent rights or copyrights.
- C. To the fullest extent permitted by Laws and Regulations, Contractor shall indemnify and hold harmless Owner and Engineer, and the officers, directors, members, partners, employees, agents, consultants and subcontractors of each and any of them from and against all claims, costs, losses, and damages (including but not limited to all fees and charges of engineers, architects, attorneys, and other professionals and all court or arbitration or other dispute resolution costs) arising out of or relating to any infringement of patent rights or copyrights incident to the use in the performance of the Work or resulting from the incorporation in the Work of any invention, design, process, product, or device not specified in the Contract Documents.

7.08 *Permits*

- A. Unless otherwise provided in the Contract Documents, Contractor shall obtain and pay for all construction permits and licenses. Owner shall assist Contractor, when necessary, in obtaining such permits and licenses. Contractor shall pay all governmental charges and inspection fees necessary for the prosecution of the Work which are applicable at the time of the submission of Contractor's Bid (or when Contractor became bound under a negotiated contract). Owner shall pay all charges of utility owners for connections for providing permanent service to the Work

7.09 *Taxes*

- A. Contractor shall pay all sales, consumer, use, and other similar taxes required to be paid by Contractor in accordance with the Laws and Regulations of the place of the Project which are applicable during the performance of the Work.

7.10 *Laws and Regulations*

- A. Contractor shall give all notices required by and shall comply with all Laws and Regulations applicable to the performance of the Work. Except where otherwise expressly required by applicable Laws and Regulations, neither Owner nor Engineer shall be responsible for monitoring Contractor's compliance with any Laws or Regulations.
- B. If Contractor performs any Work or takes any other action knowing or having reason to know that it is contrary to Laws or Regulations, Contractor shall bear all resulting costs and losses, and shall indemnify and hold harmless Owner and Engineer, and the officers, directors, members, partners, employees, agents, consultants, and subcontractors of each and any of them from and against all claims, costs, losses, and damages (including but not limited to all fees and charges of engineers, architects, attorneys, and other professionals and all court or arbitration or other dispute resolution costs) arising out of or relating to such Work or other action. It shall not be Contractor's responsibility to make certain that the Work described in the Contract Documents is in accordance with Laws and Regulations, but this shall not relieve Contractor of Contractor's obligations under Paragraph 3.03.
- C. Owner or Contractor may give notice to the other party of any changes after the submission of Contractor's Bid (or after the date when Contractor became bound under a negotiated contract) in Laws or Regulations having an effect on the cost or time of performance of the Work, including but not limited to changes in Laws or Regulations having an effect on procuring permits and on sales, use, value-added, consumption, and other similar taxes. If Owner and Contractor are unable to agree on entitlement to or on the amount or extent, if any, of any adjustment in Contract Price or Contract Times resulting from such changes, then within 30 days of such notice Contractor may submit a Change Proposal, or Owner may initiate a Claim.

7.11 *Record Documents*

- A. Contractor shall maintain in a safe place at the Site one printed record copy of all Drawings, Specifications, Addenda, Change Orders, Work Change Directives, Field Orders, written interpretations and clarifications, and approved Shop Drawings. Contractor shall keep such record documents in good order and annotate them to show changes made during construction. These record documents, together with all approved Samples, will be available to Engineer for reference. Upon completion of the Work, Contractor shall deliver these record documents to Engineer.

7.12 *Safety and Protection*

- A. Contractor shall be solely responsible for initiating, maintaining, and supervising all safety precautions and programs in connection with the Work. Such responsibility does not relieve Subcontractors of their responsibility for the safety of persons or property in the performance of their work, nor for compliance with applicable safety Laws and Regulations. Contractor shall take all necessary precautions for the safety of, and shall provide the necessary protection to prevent damage, injury, or loss to:
 - 1. all persons on the Site or who may be affected by the Work;

2. all the Work and materials and equipment to be incorporated therein, whether in storage on or off the Site; and
 3. other property at the Site or adjacent thereto, including trees, shrubs, lawns, walks, pavements, roadways, structures, other work in progress, utilities, and Underground Facilities not designated for removal, relocation, or replacement in the course of construction.
- B. Contractor shall comply with all applicable Laws and Regulations relating to the safety of persons or property, or to the protection of persons or property from damage, injury, or loss; and shall erect and maintain all necessary safeguards for such safety and protection. Contractor shall notify Owner; the owners of adjacent property, Underground Facilities, and other utilities; and other contractors and utility owners performing work at or adjacent to the Site, when prosecution of the Work may affect them, and shall cooperate with them in the protection, removal, relocation, and replacement of their property or work in progress.
 - C. Contractor shall comply with the applicable requirements of Owner's safety programs, if any. The Supplementary Conditions identify any Owner's safety programs that are applicable to the Work.
 - D. Contractor shall inform Owner and Engineer of the specific requirements of Contractor's safety program with which Owner's and Engineer's employees and representatives must comply while at the Site.
 - E. All damage, injury, or loss to any property referred to in Paragraph 7.12.A.2 or 7.12.A.3 caused, directly or indirectly, in whole or in part, by Contractor, any Subcontractor, Supplier, or any other individual or entity directly or indirectly employed by any of them to perform any of the Work, or anyone for whose acts any of them may be liable, shall be remedied by Contractor at its expense (except damage or loss attributable to the fault of Drawings or Specifications or to the acts or omissions of Owner or Engineer or anyone employed by any of them, or anyone for whose acts any of them may be liable, and not attributable, directly or indirectly, in whole or in part, to the fault or negligence of Contractor or any Subcontractor, Supplier, or other individual or entity directly or indirectly employed by any of them).
 - F. Contractor's duties and responsibilities for safety and protection shall continue until such time as all the Work is completed and Engineer has issued a notice to Owner and Contractor in accordance with Paragraph 15.06.B that the Work is acceptable (except as otherwise expressly provided in connection with Substantial Completion).
 - G. Contractor's duties and responsibilities for safety and protection shall resume whenever Contractor or any Subcontractor or Supplier returns to the Site to fulfill warranty or correction obligations, or to conduct other tasks arising from the Contract Documents.

7.13 *Safety Representative*

- A. Contractor shall designate a qualified and experienced safety representative at the Site whose duties and responsibilities shall be the prevention of accidents and the maintaining and supervising of safety precautions and programs.

7.14 *Hazard Communication Programs*

- A. Contractor shall be responsible for coordinating any exchange of material safety data sheets or other hazard communication information required to be made available to or

exchanged between or among employers at the Site in accordance with Laws or Regulations.

7.15 *Emergencies*

- A. In emergencies affecting the safety or protection of persons or the Work or property at the Site or adjacent thereto, Contractor is obligated to act to prevent threatened damage, injury, or loss. Contractor shall give Engineer prompt written notice if Contractor believes that any significant changes in the Work or variations from the Contract Documents have been caused thereby or are required as a result thereof. If Engineer determines that a change in the Contract Documents is required because of the action taken by Contractor in response to such an emergency, a Work Change Directive or Change Order will be issued.

7.16 *Shop Drawings, Samples, and Other Submittals*

A. *Shop Drawing and Sample Submittal Requirements:*

1. Before submitting a Shop Drawing or Sample, Contractor shall have:
 - a. reviewed and coordinated the Shop Drawing or Sample with other Shop Drawings and Samples and with the requirements of the Work and the Contract Documents;
 - b. determined and verified all field measurements, quantities, dimensions, specified performance and design criteria, installation requirements, materials, catalog numbers, and similar information with respect thereto;
 - c. determined and verified the suitability of all materials and equipment offered with respect to the indicated application, fabrication, shipping, handling, storage, assembly, and installation pertaining to the performance of the Work; and
 - d. determined and verified all information relative to Contractor's responsibilities for means, methods, techniques, sequences, and procedures of construction, and safety precautions and programs incident thereto.
2. Each submittal shall bear a stamp or specific written certification that Contractor has satisfied Contractor's obligations under the Contract Documents with respect to Contractor's review of that submittal, and that Contractor approves the submittal.
3. With each submittal, Contractor shall give Engineer specific written notice of any variations that the Shop Drawing or Sample may have from the requirements of the Contract Documents. This notice shall be set forth in a written communication separate from the Shop Drawings or Sample submittal; and, in addition, in the case of Shop Drawings by a specific notation made on each Shop Drawing submitted to Engineer for review and approval of each such variation.

- B. *Submittal Procedures for Shop Drawings and Samples:* Contractor shall submit Shop Drawings and Samples to Engineer for review and approval in accordance with the accepted Schedule of Submittals. Each submittal will be identified as Engineer may require.

1. *Shop Drawings:*

- a. Contractor shall submit the number of copies required in the Specifications.
- b. Data shown on the Shop Drawings will be complete with respect to quantities, dimensions, specified performance and design criteria, materials, and similar data to show Engineer the services, materials, and equipment Contractor proposes to

provide and to enable Engineer to review the information for the limited purposes required by Paragraph 7.16.D.

2. *Samples:*
 - a. Contractor shall submit the number of Samples required in the Specifications.
 - b. Contractor shall clearly identify each Sample as to material, Supplier, pertinent data such as catalog numbers, the use for which intended and other data as Engineer may require to enable Engineer to review the submittal for the limited purposes required by Paragraph 7.16.D.
3. Where a Shop Drawing or Sample is required by the Contract Documents or the Schedule of Submittals, any related Work performed prior to Engineer's review and approval of the pertinent submittal will be at the sole expense and responsibility of Contractor.
- C. *Other Submittals:* Contractor shall submit other submittals to Engineer in accordance with the accepted Schedule of Submittals, and pursuant to the applicable terms of the Specifications.
- D. *Engineer's Review:*
 1. Engineer will provide timely review of Shop Drawings and Samples in accordance with the Schedule of Submittals acceptable to Engineer. Engineer's review and approval will be only to determine if the items covered by the submittals will, after installation or incorporation in the Work, conform to the information given in the Contract Documents and be compatible with the design concept of the completed Project as a functioning whole as indicated by the Contract Documents.
 2. Engineer's review and approval will not extend to means, methods, techniques, sequences, or procedures of construction or to safety precautions or programs incident thereto.
 3. Engineer's review and approval of a separate item as such will not indicate approval of the assembly in which the item functions.
 4. Engineer's review and approval of a Shop Drawing or Sample shall not relieve Contractor from responsibility for any variation from the requirements of the Contract Documents unless Contractor has complied with the requirements of Paragraph 7.16.A.3 and Engineer has given written approval of each such variation by specific written notation thereof incorporated in or accompanying the Shop Drawing or Sample. Engineer will document any such approved variation from the requirements of the Contract Documents in a Field Order.
 5. Engineer's review and approval of a Shop Drawing or Sample shall not relieve Contractor from responsibility for complying with the requirements of Paragraph 7.16.A and B.
 6. Engineer's review and approval of a Shop Drawing or Sample, or of a variation from the requirements of the Contract Documents, shall not, under any circumstances, change the Contract Times or Contract Price, unless such changes are included in a Change Order.
 7. Neither Engineer's receipt, review, acceptance or approval of a Shop Drawing, Sample, or other submittal shall result in such item becoming a Contract Document.

8. Contractor shall perform the Work in compliance with the requirements and commitments set forth in approved Shop Drawings and Samples, subject to the provisions of Paragraph 7.16.D.4.

E. *Resubmittal Procedures:*

1. Contractor shall make corrections required by Engineer and shall return the required number of corrected copies of Shop Drawings and submit, as required, new Samples for review and approval. Contractor shall direct specific attention in writing to revisions other than the corrections called for by Engineer on previous submittals.
2. Contractor shall furnish required submittals with sufficient information and accuracy to obtain required approval of an item with no more than three submittals. Engineer will record Engineer's time for reviewing a fourth or subsequent submittal of a Shop Drawings, sample, or other item requiring approval, and Contractor shall be responsible for Engineer's charges to Owner for such time. Owner may impose a set-off against payments due to Contractor to secure reimbursement for such charges.
3. If Contractor requests a change of a previously approved submittal item, Contractor shall be responsible for Engineer's charges to Owner for its review time, and Owner may impose a set-off against payments due to Contractor to secure reimbursement for such charges, unless the need for such change is beyond the control of Contractor.

7.17 *Contractor's General Warranty and Guarantee*

- A. Contractor warrants and guarantees to Owner that all Work will be in accordance with the Contract Documents and will not be defective. Engineer and its officers, directors, members, partners, employees, agents, consultants, and subcontractors shall be entitled to rely on Contractor's warranty and guarantee.
- B. Contractor's warranty and guarantee hereunder excludes defects or damage caused by:
 1. abuse, modification, or improper maintenance or operation by persons other than Contractor, Subcontractors, Suppliers, or any other individual or entity for whom Contractor is responsible; or
 2. normal wear and tear under normal usage.
- C. Contractor's obligation to perform and complete the Work in accordance with the Contract Documents shall be absolute. None of the following will constitute an acceptance of Work that is not in accordance with the Contract Documents or a release of Contractor's obligation to perform the Work in accordance with the Contract Documents:
 1. observations by Engineer;
 2. recommendation by Engineer or payment by Owner of any progress or final payment;
 3. the issuance of a certificate of Substantial Completion by Engineer or any payment related thereto by Owner;
 4. use or occupancy of the Work or any part thereof by Owner;
 5. any review and approval of a Shop Drawing or Sample submittal;
 6. the issuance of a notice of acceptability by Engineer;
 7. any inspection, test, or approval by others; or
 8. any correction of defective Work by Owner.

- D. If the Contract requires the Contractor to accept the assignment of a contract entered into by Owner, then the specific warranties, guarantees, and correction obligations contained in the assigned contract shall govern with respect to Contractor's performance obligations to Owner for the Work described in the assigned contract.

7.18 *Indemnification*

- A. To the fullest extent permitted by Laws and Regulations, and in addition to any other obligations of Contractor under the Contract or otherwise, Contractor shall indemnify and hold harmless Owner and Engineer, and the officers, directors, members, partners, employees, agents, consultants and subcontractors of each and any of them from and against all claims, costs, losses, and damages (including but not limited to all fees and charges of engineers, architects, attorneys, and other professionals and all court or arbitration or other dispute resolution costs) arising out of or relating to the performance of the Work, provided that any such claim, cost, loss, or damage is attributable to bodily injury, sickness, disease, or death, or to injury to or destruction of tangible property (other than the Work itself), including the loss of use resulting therefrom but only to the extent caused by any negligent act or omission of Contractor, any Subcontractor, any Supplier, or any individual or entity directly or indirectly employed by any of them to perform any of the Work or anyone for whose acts any of them may be liable.
- B. In any and all claims against Owner or Engineer or any of their officers, directors, members, partners, employees, agents, consultants, or subcontractors by any employee (or the survivor or personal representative of such employee) of Contractor, any Subcontractor, any Supplier, or any individual or entity directly or indirectly employed by any of them to perform any of the Work, or anyone for whose acts any of them may be liable, the indemnification obligation under Paragraph 7.18.A shall not be limited in any way by any limitation on the amount or type of damages, compensation, or benefits payable by or for Contractor or any such Subcontractor, Supplier, or other individual or entity under workers' compensation acts, disability benefit acts, or other employee benefit acts.
- C. The indemnification obligations of Contractor under Paragraph 7.18.A shall not extend to the liability of Engineer and Engineer's officers, directors, members, partners, employees, agents, consultants and subcontractors arising out of:
 - 1. the preparation or approval of, or the failure to prepare or approve maps, Drawings, opinions, reports, surveys, Change Orders, designs, or Specifications; or
 - 2. giving directions or instructions, or failing to give them, if that is the primary cause of the injury or damage.

7.19 *Delegation of Professional Design Services*

- A. Contractor will not be required to provide professional design services unless such services are specifically required by the Contract Documents for a portion of the Work or unless such services are required to carry out Contractor's responsibilities for construction means, methods, techniques, sequences and procedures. Contractor shall not be required to provide professional services in violation of applicable Laws and Regulations.
- B. If professional design services or certifications by a design professional related to systems, materials, or equipment are specifically required of Contractor by the Contract Documents, Owner and Engineer will specify all performance and design criteria that such services must satisfy. Contractor shall cause such services or certifications to be provided by a properly licensed professional, whose signature and seal shall appear on all drawings, calculations, specifications, certifications, and other submittals prepared by such professional. Shop

Drawings and other submittals related to the Work designed or certified by such professional, if prepared by others, shall bear such professional's written approval when submitted to Engineer.

- C. Owner and Engineer shall be entitled to rely upon the adequacy, accuracy, and completeness of the services, certifications, or approvals performed by such design professionals, provided Owner and Engineer have specified to Contractor all performance and design criteria that such services must satisfy.
- D. Pursuant to this paragraph, Engineer's review and approval of design calculations and design drawings will be only for the limited purpose of checking for conformance with performance and design criteria given and the design concept expressed in the Contract Documents. Engineer's review and approval of Shop Drawings and other submittals (except design calculations and design drawings) will be only for the purpose stated in Paragraph 7.16.D.1.
- E. Contractor shall not be responsible for the adequacy of the performance or design criteria specified by Owner or Engineer.

ARTICLE 8 – OTHER WORK AT THE SITE

8.01 *Other Work*

- A. In addition to and apart from the Work under the Contract Documents, the Owner may perform other work at or adjacent to the Site. Such other work may be performed by Owner's employees, or through contracts between the Owner and third parties. Owner may also arrange to have third-party utility owners perform work on their utilities and facilities at or adjacent to the Site.
- B. If Owner performs other work at or adjacent to the Site with Owner's employees, or through contracts for such other work, then Owner shall give Contractor written notice thereof prior to starting any such other work. If Owner has advance information regarding the start of any utility work at or adjacent to the Site, Owner shall provide such information to Contractor.
- C. Contractor shall afford each other contractor that performs such other work, each utility owner performing other work, and Owner, if Owner is performing other work with Owner's employees, proper and safe access to the Site, and provide a reasonable opportunity for the introduction and storage of materials and equipment and the execution of such other work. Contractor shall do all cutting, fitting, and patching of the Work that may be required to properly connect or otherwise make its several parts come together and properly integrate with such other work. Contractor shall not endanger any work of others by cutting, excavating, or otherwise altering such work; provided, however, that Contractor may cut or alter others' work with the written consent of Engineer and the others whose work will be affected.
- D. If the proper execution or results of any part of Contractor's Work depends upon work performed by others under this Article 8, Contractor shall inspect such other work and promptly report to Engineer in writing any delays, defects, or deficiencies in such other work that render it unavailable or unsuitable for the proper execution and results of Contractor's Work. Contractor's failure to so report will constitute an acceptance of such other work as fit and proper for integration with Contractor's Work except for latent defects and deficiencies in such other work.

8.02 *Coordination*

- A. If Owner intends to contract with others for the performance of other work at or adjacent to the Site, to perform other work at or adjacent to the Site with Owner's employees, or to arrange to have utility owners perform work at or adjacent to the Site, the following will be set forth in the Supplementary Conditions or provided to Contractor prior to the start of any such other work:
 - 1. the identity of the individual or entity that will have authority and responsibility for coordination of the activities among the various contractors;
 - 2. an itemization of the specific matters to be covered by such authority and responsibility; and
 - 3. the extent of such authority and responsibilities.
- B. Unless otherwise provided in the Supplementary Conditions, Owner shall have sole authority and responsibility for such coordination.

8.03 *Legal Relationships*

- A. If, in the course of performing other work at or adjacent to the Site for Owner, the Owner's employees, any other contractor working for Owner, or any utility owner for whom the Owner is responsible causes damage to the Work or to the property of Contractor or its Subcontractors, or delays, disrupts, interferes with, or increases the scope or cost of the performance of the Work, through actions or inaction, then Contractor shall be entitled to an equitable adjustment in the Contract Price or the Contract Times, or both. Contractor must submit any Change Proposal seeking an equitable adjustment in the Contract Price or the Contract Times under this paragraph within 30 days of the damaging, delaying, disrupting, or interfering event. The entitlement to, and extent of, any such equitable adjustment shall take into account information (if any) regarding such other work that was provided to Contractor in the Contract Documents prior to the submittal of the Bid or the final negotiation of the terms of the Contract. When applicable, any such equitable adjustment in Contract Price shall be conditioned on Contractor assigning to Owner all Contractor's rights against such other contractor or utility owner with respect to the damage, delay, disruption, or interference that is the subject of the adjustment. Contractor's entitlement to an adjustment of the Contract Times is conditioned on such adjustment being essential to Contractor's ability to complete the Work within the Contract Times.
- B. Contractor shall take reasonable and customary measures to avoid damaging, delaying, disrupting, or interfering with the work of Owner, any other contractor, or any utility owner performing other work at or adjacent to the Site. If Contractor fails to take such measures and as a result damages, delays, disrupts, or interferes with the work of any such other contractor or utility owner, then Owner may impose a set-off against payments due to Contractor, and assign to such other contractor or utility owner the Owner's contractual rights against Contractor with respect to the breach of the obligations set forth in this paragraph.
- C. When Owner is performing other work at or adjacent to the Site with Owner's employees, Contractor shall be liable to Owner for damage to such other work, and for the reasonable direct delay, disruption, and interference costs incurred by Owner as a result of Contractor's failure to take reasonable and customary measures with respect to Owner's other work. In response to such damage, delay, disruption, or interference, Owner may impose a set-off against payments due to Contractor.

- D. If Contractor damages, delays, disrupts, or interferes with the work of any other contractor, or any utility owner performing other work at or adjacent to the Site, through Contractor's failure to take reasonable and customary measures to avoid such impacts, or if any claim arising out of Contractor's actions, inactions, or negligence in performance of the Work at or adjacent to the Site is made by any such other contractor or utility owner against Contractor, Owner, or Engineer, then Contractor shall (1) promptly attempt to settle the claim as to all parties through negotiations with such other contractor or utility owner, or otherwise resolve the claim by arbitration or other dispute resolution proceeding or at law, and (2) indemnify and hold harmless Owner and Engineer, and the officers, directors, members, partners, employees, agents, consultants and subcontractors of each and any of them from and against any such claims, and against all costs, losses, and damages (including but not limited to all fees and charges of engineers, architects, attorneys, and other professionals and all court or arbitration or other dispute resolution costs) arising out of or relating to such damage, delay, disruption, or interference.

ARTICLE 9 – OWNER'S RESPONSIBILITIES

9.01 *Communications to Contractor*

- A. Except as otherwise provided in these General Conditions, Owner shall issue all communications to Contractor through Engineer.

9.02 *Replacement of Engineer*

- A. Owner may at its discretion appoint an engineer to replace Engineer, provided Contractor makes no reasonable objection to the replacement engineer. The replacement engineer's status under the Contract Documents shall be that of the former Engineer.

9.03 *Furnish Data*

- A. Owner shall promptly furnish the data required of Owner under the Contract Documents.

9.04 *Pay When Due*

- A. Owner shall make payments to Contractor when they are due as provided in the Agreement.

9.05 *Lands and Easements; Reports, Tests, and Drawings*

- A. Owner's duties with respect to providing lands and easements are set forth in Paragraph 5.01.
- B. Owner's duties with respect to providing engineering surveys to establish reference points are set forth in Paragraph 4.03.
- C. Article 5 refers to Owner's identifying and making available to Contractor copies of reports of explorations and tests of conditions at the Site, and drawings of physical conditions relating to existing surface or subsurface structures at the Site.

9.06 *Insurance*

- A. Owner's responsibilities, if any, with respect to purchasing and maintaining liability and property insurance are set forth in Article 6.

9.07 *Change Orders*

- A. Owner's responsibilities with respect to Change Orders are set forth in Article 11.

9.08 *Inspections, Tests, and Approvals*

- A. Owner's responsibility with respect to certain inspections, tests, and approvals is set forth in Paragraph 14.02.B.

9.09 *Limitations on Owner's Responsibilities*

- A. The Owner shall not supervise, direct, or have control or authority over, nor be responsible for, Contractor's means, methods, techniques, sequences, or procedures of construction, or the safety precautions and programs incident thereto, or for any failure of Contractor to comply with Laws and Regulations applicable to the performance of the Work. Owner will not be responsible for Contractor's failure to perform the Work in accordance with the Contract Documents.

9.10 *Undisclosed Hazardous Environmental Condition*

- A. Owner's responsibility in respect to an undisclosed Hazardous Environmental Condition is set forth in Paragraph 5.06.

9.11 *Evidence of Financial Arrangements*

- A. Upon request of Contractor, Owner shall furnish Contractor reasonable evidence that financial arrangements have been made to satisfy Owner's obligations under the Contract Documents (including obligations under proposed changes in the Work).

9.12 *Safety Programs*

- A. While at the Site, Owner's employees and representatives shall comply with the specific applicable requirements of Contractor's safety programs of which Owner has been informed.
- B. Owner shall furnish copies of any applicable Owner safety programs to Contractor.

ARTICLE 10 – ENGINEER'S STATUS DURING CONSTRUCTION

10.01 *Owner's Representative*

- A. Engineer will be Owner's representative during the construction period. The duties and responsibilities and the limitations of authority of Engineer as Owner's representative during construction are set forth in the Contract.

10.02 *Visits to Site*

- A. Engineer will make visits to the Site at intervals appropriate to the various stages of construction as Engineer deems necessary in order to observe as an experienced and qualified design professional the progress that has been made and the quality of the various aspects of Contractor's executed Work. Based on information obtained during such visits and observations, Engineer, for the benefit of Owner, will determine, in general, if the Work is proceeding in accordance with the Contract Documents. Engineer will not be required to make exhaustive or continuous inspections on the Site to check the quality or quantity of the Work. Engineer's efforts will be directed toward providing for Owner a greater degree of confidence that the completed Work will conform generally to the Contract Documents. On the basis of such visits and observations, Engineer will keep Owner informed of the progress of the Work and will endeavor to guard Owner against defective Work.
- B. Engineer's visits and observations are subject to all the limitations on Engineer's authority and responsibility set forth in Paragraph 10.08. Particularly, but without limitation, during

or as a result of Engineer's visits or observations of Contractor's Work, Engineer will not supervise, direct, control, or have authority over or be responsible for Contractor's means, methods, techniques, sequences, or procedures of construction, or the safety precautions and programs incident thereto, or for any failure of Contractor to comply with Laws and Regulations applicable to the performance of the Work.

10.03 *Project Representative*

- A. If Owner and Engineer have agreed that Engineer will furnish a Resident Project Representative to represent Engineer at the Site and assist Engineer in observing the progress and quality of the Work, then the authority and responsibilities of any such Resident Project Representative will be as provided in the Supplementary Conditions, and limitations on the responsibilities thereof will be as provided in Paragraph 10.08. If Owner designates another representative or agent to represent Owner at the Site who is not Engineer's consultant, agent, or employee, the responsibilities and authority and limitations thereon of such other individual or entity will be as provided in the Supplementary Conditions.

10.04 *Rejecting Defective Work*

- A. Engineer has the authority to reject Work in accordance with Article 14.

10.05 *Shop Drawings, Change Orders and Payments*

- A. Engineer's authority, and limitations thereof, as to Shop Drawings and Samples, are set forth in Paragraph 7.16.
- B. Engineer's authority, and limitations thereof, as to design calculations and design drawings submitted in response to a delegation of professional design services, if any, are set forth in Paragraph 7.19.
- C. Engineer's authority as to Change Orders is set forth in Article 11.
- D. Engineer's authority as to Applications for Payment is set forth in Article 15.

10.06 *Determinations for Unit Price Work*

- A. Engineer will determine the actual quantities and classifications of Unit Price Work performed by Contractor as set forth in Paragraph 13.03.

10.07 *Decisions on Requirements of Contract Documents and Acceptability of Work*

- A. Engineer will render decisions regarding the requirements of the Contract Documents, and judge the acceptability of the Work, pursuant to the specific procedures set forth herein for initial interpretations, Change Proposals, and acceptance of the Work. In rendering such decisions and judgments, Engineer will not show partiality to Owner or Contractor, and will not be liable to Owner, Contractor, or others in connection with any proceedings, interpretations, decisions, or judgments conducted or rendered in good faith.

10.08 *Limitations on Engineer's Authority and Responsibilities*

- A. Neither Engineer's authority or responsibility under this Article 10 or under any other provision of the Contract, nor any decision made by Engineer in good faith either to exercise or not exercise such authority or responsibility or the undertaking, exercise, or performance of any authority or responsibility by Engineer, shall create, impose, or give rise to any duty in contract, tort, or otherwise owed by Engineer to Contractor, any Subcontractor, any Supplier, any other individual or entity, or to any surety for or employee or agent of any of them.

- B. Engineer will not supervise, direct, control, or have authority over or be responsible for Contractor's means, methods, techniques, sequences, or procedures of construction, or the safety precautions and programs incident thereto, or for any failure of Contractor to comply with Laws and Regulations applicable to the performance of the Work. Engineer will not be responsible for Contractor's failure to perform the Work in accordance with the Contract Documents.
- C. Engineer will not be responsible for the acts or omissions of Contractor or of any Subcontractor, any Supplier, or of any other individual or entity performing any of the Work.
- D. Engineer's review of the final Application for Payment and accompanying documentation and all maintenance and operating instructions, schedules, guarantees, bonds, certificates of inspection, tests and approvals, and other documentation required to be delivered by Paragraph 15.06.A will only be to determine generally that their content complies with the requirements of, and in the case of certificates of inspections, tests, and approvals, that the results certified indicate compliance with the Contract Documents.
- E. The limitations upon authority and responsibility set forth in this Paragraph 10.08 shall also apply to the Resident Project Representative, if any.

10.09 *Compliance with Safety Program*

- A. While at the Site, Engineer's employees and representatives will comply with the specific applicable requirements of Owner's and Contractor's safety programs (if any) of which Engineer has been informed.

ARTICLE 11 – AMENDING THE CONTRACT DOCUMENTS; CHANGES IN THE WORK

11.01 *Amending and Supplementing Contract Documents*

- A. The Contract Documents may be amended or supplemented by a Change Order, a Work Change Directive, or a Field Order.
 - 1. *Change Orders:*
 - a. If an amendment or supplement to the Contract Documents includes a change in the Contract Price or the Contract Times, such amendment or supplement must be set forth in a Change Order. A Change Order also may be used to establish amendments and supplements of the Contract Documents that do not affect the Contract Price or Contract Times.
 - b. Owner and Contractor may amend those terms and conditions of the Contract Documents that do not involve (1) the performance or acceptability of the Work, (2) the design (as set forth in the Drawings, Specifications, or otherwise), or (3) other engineering or technical matters, without the recommendation of the Engineer. Such an amendment shall be set forth in a Change Order.
 - 2. *Work Change Directives:* A Work Change Directive will not change the Contract Price or the Contract Times but is evidence that the parties expect that the modification ordered or documented by a Work Change Directive will be incorporated in a subsequently issued Change Order, following negotiations by the parties as to the Work Change Directive's effect, if any, on the Contract Price and Contract Times; or, if negotiations are unsuccessful, by a determination under the terms of the Contract Documents governing adjustments, expressly including Paragraph 11.04 regarding change of Contract Price. Contractor must submit any Change Proposal seeking an

adjustment of the Contract Price or the Contract Times, or both, no later than 30 days after the completion of the Work set out in the Work Change Directive. Owner must submit any Claim seeking an adjustment of the Contract Price or the Contract Times, or both, no later than 60 days after issuance of the Work Change Directive.

3. *Field Orders*: Engineer may authorize minor changes in the Work if the changes do not involve an adjustment in the Contract Price or the Contract Times and are compatible with the design concept of the completed Project as a functioning whole as indicated by the Contract Documents. Such changes will be accomplished by a Field Order and will be binding on Owner and also on Contractor, which shall perform the Work involved promptly. If Contractor believes that a Field Order justifies an adjustment in the Contract Price or Contract Times, or both, then before proceeding with the Work at issue, Contractor shall submit a Change Proposal as provided herein.

11.02 *Owner-Authorized Changes in the Work*

- A. Without invalidating the Contract and without notice to any surety, Owner may, at any time or from time to time, order additions, deletions, or revisions in the Work. Such changes shall be supported by Engineer's recommendation, to the extent the change involves the design (as set forth in the Drawings, Specifications, or otherwise), or other engineering or technical matters. Such changes may be accomplished by a Change Order, if Owner and Contractor have agreed as to the effect, if any, of the changes on Contract Times or Contract Price; or by a Work Change Directive. Upon receipt of any such document, Contractor shall promptly proceed with the Work involved; or, in the case of a deletion in the Work, promptly cease construction activities with respect to such deleted Work. Added or revised Work shall be performed under the applicable conditions of the Contract Documents. Nothing in this paragraph shall obligate Contractor to undertake work that Contractor reasonably concludes cannot be performed in a manner consistent with Contractor's safety obligations under the Contract Documents or Laws and Regulations.

11.03 *Unauthorized Changes in the Work*

- A. Contractor shall not be entitled to an increase in the Contract Price or an extension of the Contract Times with respect to any work performed that is not required by the Contract Documents, as amended, modified, or supplemented, except in the case of an emergency as provided in Paragraph 7.15 or in the case of uncovering Work as provided in Paragraph 14.05.

11.04 *Change of Contract Price*

- A. The Contract Price may only be changed by a Change Order. Any Change Proposal for an adjustment in the Contract Price shall comply with the provisions of Paragraph 11.06. Any Claim for an adjustment of Contract Price shall comply with the provisions of Article 12.
- B. An adjustment in the Contract Price will be determined as follows:
 1. where the Work involved is covered by unit prices contained in the Contract Documents, then by application of such unit prices to the quantities of the items involved (subject to the provisions of Paragraph 13.03); or
 2. where the Work involved is not covered by unit prices contained in the Contract Documents, then by a mutually agreed lump sum (which may include an allowance for overhead and profit not necessarily in accordance with Paragraph 11.04.C.2); or
 3. where the Work involved is not covered by unit prices contained in the Contract Documents and the parties do not reach mutual agreement to a lump sum, then on

the basis of the Cost of the Work (determined as provided in Paragraph 13.01) plus a Contractor's fee for overhead and profit (determined as provided in Paragraph 11.04.C).

- C. *Contractor's Fee*: When applicable, the Contractor's fee for overhead and profit shall be determined as follows:
1. a mutually acceptable fixed fee; or
 2. if a fixed fee is not agreed upon, then a fee based on the following percentages of the various portions of the Cost of the Work:
 - a. for costs incurred under Paragraphs 13.01.B.1 and 13.01.B.2, the Contractor's fee shall be 15 percent;
 - b. for costs incurred under Paragraph 13.01.B.3, the Contractor's fee shall be five percent;
 - c. where one or more tiers of subcontracts are on the basis of Cost of the Work plus a fee and no fixed fee is agreed upon, the intent of Paragraphs 11.04.C.2.a and 11.04.C.2.b is that the Contractor's fee shall be based on: (1) a fee of 15 percent of the costs incurred under Paragraphs 13.01.A.1 and 13.01.A.2 by the Subcontractor that actually performs the Work, at whatever tier, and (2) with respect to Contractor itself and to any Subcontractors of a tier higher than that of the Subcontractor that actually performs the Work, a fee of five percent of the amount (fee plus underlying costs incurred) attributable to the next lower tier Subcontractor; provided, however, that for any such subcontracted work the maximum total fee to be paid by Owner shall be no greater than 27 percent of the costs incurred by the Subcontractor that actually performs the work;
 - d. no fee shall be payable on the basis of costs itemized under Paragraphs 13.01.B.4, 13.01.B.5, and 13.01.C;
 - e. the amount of credit to be allowed by Contractor to Owner for any change which results in a net decrease in cost will be the amount of the actual net decrease in cost plus a deduction in Contractor's fee by an amount equal to five percent of such net decrease; and
 - f. when both additions and credits are involved in any one change, the adjustment in Contractor's fee shall be computed on the basis of the net change in accordance with Paragraphs 11.04.C.2.a through 11.04.C.2.e, inclusive.

11.05 *Change of Contract Times*

- A. The Contract Times may only be changed by a Change Order. Any Change Proposal for an adjustment in the Contract Times shall comply with the provisions of Paragraph 11.06. Any Claim for an adjustment in the Contract Times shall comply with the provisions of Article 12.
- B. An adjustment of the Contract Times shall be subject to the limitations set forth in Paragraph 4.05, concerning delays in Contractor's progress.

11.06 *Change Proposals*

- A. Contractor shall submit a Change Proposal to Engineer to request an adjustment in the Contract Times or Contract Price; appeal an initial decision by Engineer concerning the requirements of the Contract Documents or relating to the acceptability of the Work under the Contract Documents; contest a set-off against payment due; or seek other relief under

the Contract. The Change Proposal shall specify any proposed change in Contract Times or Contract Price, or both, or other proposed relief, and explain the reason for the proposed change, with citations to any governing or applicable provisions of the Contract Documents.

1. *Procedures:* Contractor shall submit each Change Proposal to Engineer promptly (but in no event later than 30 days) after the start of the event giving rise thereto, or after such initial decision. The Contractor shall submit supporting data, including the proposed change in Contract Price or Contract Time (if any), to the Engineer and Owner within 15 days after the submittal of the Change Proposal. The supporting data shall be accompanied by a written statement that the supporting data are accurate and complete, and that any requested time or price adjustment is the entire adjustment to which Contractor believes it is entitled as a result of said event. Engineer will advise Owner regarding the Change Proposal, and consider any comments or response from Owner regarding the Change Proposal.
 2. *Engineer's Action:* Engineer will review each Change Proposal and, within 30 days after receipt of the Contractor's supporting data, either deny the Change Proposal in whole, approve it in whole, or deny it in part and approve it in part. Such actions shall be in writing, with a copy provided to Owner and Contractor. If Engineer does not take action on the Change Proposal within 30 days, then either Owner or Contractor may at any time thereafter submit a letter to the other party indicating that as a result of Engineer's inaction the Change Proposal is deemed denied, thereby commencing the time for appeal of the denial under Article 12.
 3. *Binding Decision:* Engineer's decision will be final and binding upon Owner and Contractor, unless Owner or Contractor appeals the decision by filing a Claim under Article 12.
- B. *Resolution of Certain Change Proposals:* If the Change Proposal does not involve the design (as set forth in the Drawings, Specifications, or otherwise), the acceptability of the Work, or other engineering or technical matters, then Engineer will notify the parties that the Engineer is unable to resolve the Change Proposal. For purposes of further resolution of such a Change Proposal, such notice shall be deemed a denial, and Contractor may choose to seek resolution under the terms of Article 12.

11.07 Execution of Change Orders

- A. Owner and Contractor shall execute appropriate Change Orders covering:
1. changes in the Contract Price or Contract Times which are agreed to by the parties, including any undisputed sum or amount of time for Work actually performed in accordance with a Work Change Directive;
 2. changes in Contract Price resulting from an Owner set-off, unless Contractor has duly contested such set-off;
 3. changes in the Work which are: (a) ordered by Owner pursuant to Paragraph 11.02, (b) required because of Owner's acceptance of defective Work under Paragraph 14.04 or Owner's correction of defective Work under Paragraph 14.07, or (c) agreed to by the parties, subject to the need for Engineer's recommendation if the change in the Work involves the design (as set forth in the Drawings, Specifications, or otherwise), or other engineering or technical matters; and
 4. changes in the Contract Price or Contract Times, or other changes, which embody the substance of any final and binding results under Paragraph 11.06, or Article 12.

- B. If Owner or Contractor refuses to execute a Change Order that is required to be executed under the terms of this Paragraph 11.07, it shall be deemed to be of full force and effect, as if fully executed.

11.08 *Notification to Surety*

- A. If the provisions of any bond require notice to be given to a surety of any change affecting the general scope of the Work or the provisions of the Contract Documents (including, but not limited to, Contract Price or Contract Times), the giving of any such notice will be Contractor's responsibility. The amount of each applicable bond will be adjusted to reflect the effect of any such change.

ARTICLE 12 – CLAIMS

12.01 *Claims*

- A. *Claims Process:* The following disputes between Owner and Contractor shall be submitted to the Claims process set forth in this Article:
 - 1. Appeals by Owner or Contractor of Engineer's decisions regarding Change Proposals;
 - 2. Owner demands for adjustments in the Contract Price or Contract Times, or other relief under the Contract Documents; and
 - 3. Disputes that Engineer has been unable to address because they do not involve the design (as set forth in the Drawings, Specifications, or otherwise), the acceptability of the Work, or other engineering or technical matters.
- B. *Submittal of Claim:* The party submitting a Claim shall deliver it directly to the other party to the Contract promptly (but in no event later than 30 days) after the start of the event giving rise thereto; in the case of appeals regarding Change Proposals within 30 days of the decision under appeal. The party submitting the Claim shall also furnish a copy to the Engineer, for its information only. The responsibility to substantiate a Claim shall rest with the party making the Claim. In the case of a Claim by Contractor seeking an increase in the Contract Times or Contract Price, or both, Contractor shall certify that the Claim is made in good faith, that the supporting data are accurate and complete, and that to the best of Contractor's knowledge and belief the amount of time or money requested accurately reflects the full amount to which Contractor is entitled.
- C. *Review and Resolution:* The party receiving a Claim shall review it thoroughly, giving full consideration to its merits. The two parties shall seek to resolve the Claim through the exchange of information and direct negotiations. The parties may extend the time for resolving the Claim by mutual agreement. All actions taken on a Claim shall be stated in writing and submitted to the other party, with a copy to Engineer.
- D. *Mediation:*
 - 1. At any time after initiation of a Claim, Owner and Contractor may mutually agree to mediation of the underlying dispute. The agreement to mediate shall stay the Claim submittal and response process.
 - 2. If Owner and Contractor agree to mediation, then after 60 days from such agreement, either Owner or Contractor may unilaterally terminate the mediation process, and the Claim submittal and decision process shall resume as of the date of the termination. If the mediation proceeds but is unsuccessful in resolving the dispute, the Claim

submittal and decision process shall resume as of the date of the conclusion of the mediation, as determined by the mediator.

3. Owner and Contractor shall each pay one-half of the mediator's fees and costs.
- E. *Partial Approval*: If the party receiving a Claim approves the Claim in part and denies it in part, such action shall be final and binding unless within 30 days of such action the other party invokes the procedure set forth in Article 17 for final resolution of disputes.
- F. *Denial of Claim*: If efforts to resolve a Claim are not successful, the party receiving the Claim may deny it by giving written notice of denial to the other party. If the receiving party does not take action on the Claim within 90 days, then either Owner or Contractor may at any time thereafter submit a letter to the other party indicating that as a result of the inaction, the Claim is deemed denied, thereby commencing the time for appeal of the denial. A denial of the Claim shall be final and binding unless within 30 days of the denial the other party invokes the procedure set forth in Article 17 for the final resolution of disputes.
- G. *Final and Binding Results*: If the parties reach a mutual agreement regarding a Claim, whether through approval of the Claim, direct negotiations, mediation, or otherwise; or if a Claim is approved in part and denied in part, or denied in full, and such actions become final and binding; then the results of the agreement or action on the Claim shall be incorporated in a Change Order to the extent they affect the Contract, including the Work, the Contract Times, or the Contract Price.

ARTICLE 13 – COST OF THE WORK; ALLOWANCES; UNIT PRICE WORK

13.01 *Cost of the Work*

- A. *Purposes for Determination of Cost of the Work*: The term Cost of the Work means the sum of all costs necessary for the proper performance of the Work at issue, as further defined below. The provisions of this Paragraph 13.01 are used for two distinct purposes:
 1. To determine Cost of the Work when Cost of the Work is a component of the Contract Price, under cost-plus-fee, time-and-materials, or other cost-based terms; or
 2. To determine the value of a Change Order, Change Proposal, Claim, set-off, or other adjustment in Contract Price. When the value of any such adjustment is determined on the basis of Cost of the Work, Contractor is entitled only to those additional or incremental costs required because of the change in the Work or because of the event giving rise to the adjustment.
- B. *Costs Included*: Except as otherwise may be agreed to in writing by Owner, costs included in the Cost of the Work shall be in amounts no higher than those prevailing in the locality of the Project, shall not include any of the costs itemized in Paragraph 13.01.C, and shall include only the following items:
 1. Payroll costs for employees in the direct employ of Contractor in the performance of the Work under schedules of job classifications agreed upon by Owner and Contractor. Such employees shall include, without limitation, superintendents, foremen, and other personnel employed full time on the Work. Payroll costs for employees not employed full time on the Work shall be apportioned on the basis of their time spent on the Work. Payroll costs shall include, but not be limited to, salaries and wages plus the cost of fringe benefits, which shall include social security contributions, unemployment, excise, and payroll taxes, workers' compensation, health and retirement benefits, bonuses, sick leave, and vacation and holiday pay applicable

thereto. The expenses of performing Work outside of regular working hours, on Saturday, Sunday, or legal holidays, shall be included in the above to the extent authorized by Owner.

2. Cost of all materials and equipment furnished and incorporated in the Work, including costs of transportation and storage thereof, and Suppliers' field services required in connection therewith. All cash discounts shall accrue to Contractor unless Owner deposits funds with Contractor with which to make payments, in which case the cash discounts shall accrue to Owner. All trade discounts, rebates, and refunds and returns from sale of surplus materials and equipment shall accrue to Owner, and Contractor shall make provisions so that they may be obtained.
3. Payments made by Contractor to Subcontractors for Work performed by Subcontractors. If required by Owner, Contractor shall obtain competitive bids from subcontractors acceptable to Owner and Contractor and shall deliver such bids to Owner, who will then determine, with the advice of Engineer, which bids, if any, will be acceptable. If any subcontract provides that the Subcontractor is to be paid on the basis of Cost of the Work plus a fee, the Subcontractor's Cost of the Work and fee shall be determined in the same manner as Contractor's Cost of the Work and fee as provided in this Paragraph 13.01.
4. Costs of special consultants (including but not limited to engineers, architects, testing laboratories, surveyors, attorneys, and accountants) employed for services specifically related to the Work.
5. Supplemental costs including the following:
 - a. The proportion of necessary transportation, travel, and subsistence expenses of Contractor's employees incurred in discharge of duties connected with the Work.
 - b. Cost, including transportation and maintenance, of all materials, supplies, equipment, machinery, appliances, office, and temporary facilities at the Site, and hand tools not owned by the workers, which are consumed in the performance of the Work, and cost, less market value, of such items used but not consumed which remain the property of Contractor.
 - c. Rentals of all construction equipment and machinery, and the parts thereof, whether rented from Contractor or others in accordance with rental agreements approved by Owner with the advice of Engineer, and the costs of transportation, loading, unloading, assembly, dismantling, and removal thereof. All such costs shall be in accordance with the terms of said rental agreements. The rental of any such equipment, machinery, or parts shall cease when the use thereof is no longer necessary for the Work.
 - d. Sales, consumer, use, and other similar taxes related to the Work, and for which Contractor is liable, as imposed by Laws and Regulations.
 - e. Deposits lost for causes other than negligence of Contractor, any Subcontractor, or anyone directly or indirectly employed by any of them or for whose acts any of them may be liable, and royalty payments and fees for permits and licenses.
 - f. Losses and damages (and related expenses) caused by damage to the Work, not compensated by insurance or otherwise, sustained by Contractor in connection with the performance of the Work (except losses and damages within the deductible amounts of property insurance established in accordance with Paragraph 6.05), provided such losses and damages have resulted from causes

other than the negligence of Contractor, any Subcontractor, or anyone directly or indirectly employed by any of them or for whose acts any of them may be liable. Such losses shall include settlements made with the written consent and approval of Owner. No such losses, damages, and expenses shall be included in the Cost of the Work for the purpose of determining Contractor's fee.

- g. The cost of utilities, fuel, and sanitary facilities at the Site.
- h. Minor expenses such as communication service at the Site, express and courier services, and similar petty cash items in connection with the Work.
- i. The costs of premiums for all bonds and insurance that Contractor is required by the Contract Documents to purchase and maintain.

C. *Costs Excluded:* The term Cost of the Work shall not include any of the following items:

- 1. Payroll costs and other compensation of Contractor's officers, executives, principals (of partnerships and sole proprietorships), general managers, safety managers, engineers, architects, estimators, attorneys, auditors, accountants, purchasing and contracting agents, expeditors, timekeepers, clerks, and other personnel employed by Contractor, whether at the Site or in Contractor's principal or branch office for general administration of the Work and not specifically included in the agreed upon schedule of job classifications referred to in Paragraph 13.01.B.1 or specifically covered by Paragraph 13.01.B.4. The payroll costs and other compensation excluded here are to be considered administrative costs covered by the Contractor's fee.
- 2. Expenses of Contractor's principal and branch offices other than Contractor's office at the Site.
- 3. Any part of Contractor's capital expenses, including interest on Contractor's capital employed for the Work and charges against Contractor for delinquent payments.
- 4. Costs due to the negligence of Contractor, any Subcontractor, or anyone directly or indirectly employed by any of them or for whose acts any of them may be liable, including but not limited to, the correction of defective Work, disposal of materials or equipment wrongly supplied, and making good any damage to property.
- 5. Other overhead or general expense costs of any kind and the costs of any item not specifically and expressly included in Paragraph 13.01.B.

D. *Contractor's Fee:* When the Work as a whole is performed on the basis of cost-plus, Contractor's fee shall be determined as set forth in the Agreement. When the value of any Work covered by a Change Order, Change Proposal, Claim, set-off, or other adjustment in Contract Price is determined on the basis of Cost of the Work, Contractor's fee shall be determined as set forth in Paragraph 11.04.C.

E. *Documentation:* Whenever the Cost of the Work for any purpose is to be determined pursuant to this Article 13, Contractor will establish and maintain records thereof in accordance with generally accepted accounting practices and submit in a form acceptable to Engineer an itemized cost breakdown together with supporting data.

13.02 Allowances

- A. It is understood that Contractor has included in the Contract Price all allowances so named in the Contract Documents and shall cause the Work so covered to be performed for such sums and by such persons or entities as may be acceptable to Owner and Engineer.

- B. *Cash Allowances*: Contractor agrees that:
 - 1. the cash allowances include the cost to Contractor (less any applicable trade discounts) of materials and equipment required by the allowances to be delivered at the Site, and all applicable taxes; and
 - 2. Contractor's costs for unloading and handling on the Site, labor, installation, overhead, profit, and other expenses contemplated for the cash allowances have been included in the Contract Price and not in the allowances, and no demand for additional payment on account of any of the foregoing will be valid.
- C. *Contingency Allowance*: Contractor agrees that a contingency allowance, if any, is for the sole use of Owner to cover unanticipated costs.
- D. Prior to final payment, an appropriate Change Order will be issued as recommended by Engineer to reflect actual amounts due Contractor on account of Work covered by allowances, and the Contract Price shall be correspondingly adjusted.

13.03 *Unit Price Work*

- A. Where the Contract Documents provide that all or part of the Work is to be Unit Price Work, initially the Contract Price will be deemed to include for all Unit Price Work an amount equal to the sum of the unit price for each separately identified item of Unit Price Work times the estimated quantity of each item as indicated in the Agreement.
- B. The estimated quantities of items of Unit Price Work are not guaranteed and are solely for the purpose of comparison of Bids and determining an initial Contract Price. Payments to Contractor for Unit Price Work will be based on actual quantities.
- C. Each unit price will be deemed to include an amount considered by Contractor to be adequate to cover Contractor's overhead and profit for each separately identified item.
- D. Engineer will determine the actual quantities and classifications of Unit Price Work performed by Contractor. Engineer will review with Contractor the Engineer's preliminary determinations on such matters before rendering a written decision thereon (by recommendation of an Application for Payment or otherwise). Engineer's written decision thereon will be final and binding (except as modified by Engineer to reflect changed factual conditions or more accurate data) upon Owner and Contractor, subject to the provisions of the following paragraph.
- E. Within 30 days of Engineer's written decision under the preceding paragraph, Contractor may submit a Change Proposal, or Owner may file a Claim, seeking an adjustment in the Contract Price if:
 - 1. the quantity of any item of Unit Price Work performed by Contractor differs materially and significantly from the estimated quantity of such item indicated in the Agreement;
 - 2. there is no corresponding adjustment with respect to any other item of Work; and
 - 3. Contractor believes that it is entitled to an increase in Contract Price as a result of having incurred additional expense or Owner believes that Owner is entitled to a decrease in Contract Price, and the parties are unable to agree as to the amount of any such increase or decrease.

ARTICLE 14 – TESTS AND INSPECTIONS; CORRECTION, REMOVAL OR ACCEPTANCE OF DEFECTIVE WORK

14.01 Access to Work

- A. Owner, Engineer, their consultants and other representatives and personnel of Owner, independent testing laboratories, and authorities having jurisdiction will have access to the Site and the Work at reasonable times for their observation, inspection, and testing. Contractor shall provide them proper and safe conditions for such access and advise them of Contractor's safety procedures and programs so that they may comply therewith as applicable.

14.02 Tests, Inspections, and Approvals

- A. Contractor shall give Engineer timely notice of readiness of the Work (or specific parts thereof) for all required inspections and tests, and shall cooperate with inspection and testing personnel to facilitate required inspections and tests.
- B. Owner shall retain and pay for the services of an independent inspector, testing laboratory, or other qualified individual or entity to perform all inspections and tests expressly required by the Contract Documents to be furnished and paid for by Owner, except that costs incurred in connection with tests or inspections of covered Work shall be governed by the provisions of Paragraph 14.05.
- C. If Laws or Regulations of any public body having jurisdiction require any Work (or part thereof) specifically to be inspected, tested, or approved by an employee or other representative of such public body, Contractor shall assume full responsibility for arranging and obtaining such inspections, tests, or approvals, pay all costs in connection therewith, and furnish Engineer the required certificates of inspection or approval.
- D. Contractor shall be responsible for arranging, obtaining, and paying for all inspections and tests required:
 - 1. by the Contract Documents, unless the Contract Documents expressly allocate responsibility for a specific inspection or test to Owner;
 - 2. to attain Owner's and Engineer's acceptance of materials or equipment to be incorporated in the Work;
 - 3. by manufacturers of equipment furnished under the Contract Documents;
 - 4. for testing, adjusting, and balancing of mechanical, electrical, and other equipment to be incorporated into the Work; and
 - 5. for acceptance of materials, mix designs, or equipment submitted for approval prior to Contractor's purchase thereof for incorporation in the Work.

Such inspections and tests shall be performed by independent inspectors, testing laboratories, or other qualified individuals or entities acceptable to Owner and Engineer.

- E. If the Contract Documents require the Work (or part thereof) to be approved by Owner, Engineer, or another designated individual or entity, then Contractor shall assume full responsibility for arranging and obtaining such approvals.
- F. If any Work (or the work of others) that is to be inspected, tested, or approved is covered by Contractor without written concurrence of Engineer, Contractor shall, if requested by Engineer, uncover such Work for observation. Such uncovering shall be at Contractor's expense unless Contractor had given Engineer timely notice of Contractor's intention to

cover the same and Engineer had not acted with reasonable promptness in response to such notice.

14.03 *Defective Work*

- A. *Contractor's Obligation:* It is Contractor's obligation to assure that the Work is not defective.
- B. *Engineer's Authority:* Engineer has the authority to determine whether Work is defective, and to reject defective Work.
- C. *Notice of Defects:* Prompt notice of all defective Work of which Owner or Engineer has actual knowledge will be given to Contractor.
- D. *Correction, or Removal and Replacement:* Promptly after receipt of written notice of defective Work, Contractor shall correct all such defective Work, whether or not fabricated, installed, or completed, or, if Engineer has rejected the defective Work, remove it from the Project and replace it with Work that is not defective.
- E. *Preservation of Warranties:* When correcting defective Work, Contractor shall take no action that would void or otherwise impair Owner's special warranty and guarantee, if any, on said Work.
- F. *Costs and Damages:* In addition to its correction, removal, and replacement obligations with respect to defective Work, Contractor shall pay all claims, costs, losses, and damages arising out of or relating to defective Work, including but not limited to the cost of the inspection, testing, correction, removal, replacement, or reconstruction of such defective Work, fines levied against Owner by governmental authorities because the Work is defective, and the costs of repair or replacement of work of others resulting from defective Work. Prior to final payment, if Owner and Contractor are unable to agree as to the measure of such claims, costs, losses, and damages resulting from defective Work, then Owner may impose a reasonable set-off against payments due under Article 15.

14.04 *Acceptance of Defective Work*

- A. If, instead of requiring correction or removal and replacement of defective Work, Owner prefers to accept it, Owner may do so (subject, if such acceptance occurs prior to final payment, to Engineer's confirmation that such acceptance is in general accord with the design intent and applicable engineering principles, and will not endanger public safety). Contractor shall pay all claims, costs, losses, and damages attributable to Owner's evaluation of and determination to accept such defective Work (such costs to be approved by Engineer as to reasonableness), and for the diminished value of the Work to the extent not otherwise paid by Contractor. If any such acceptance occurs prior to final payment, the necessary revisions in the Contract Documents with respect to the Work shall be incorporated in a Change Order. If the parties are unable to agree as to the decrease in the Contract Price, reflecting the diminished value of Work so accepted, then Owner may impose a reasonable set-off against payments due under Article 15. If the acceptance of defective Work occurs after final payment, Contractor shall pay an appropriate amount to Owner.

14.05 *Uncovering Work*

- A. Engineer has the authority to require additional inspection or testing of the Work, whether or not the Work is fabricated, installed, or completed.

- B. If any Work is covered contrary to the written request of Engineer, then Contractor shall, if requested by Engineer, uncover such Work for Engineer's observation, and then replace the covering, all at Contractor's expense.
- C. If Engineer considers it necessary or advisable that covered Work be observed by Engineer or inspected or tested by others, then Contractor, at Engineer's request, shall uncover, expose, or otherwise make available for observation, inspection, or testing as Engineer may require, that portion of the Work in question, and provide all necessary labor, material, and equipment.
 - 1. If it is found that the uncovered Work is defective, Contractor shall be responsible for all claims, costs, losses, and damages arising out of or relating to such uncovering, exposure, observation, inspection, and testing, and of satisfactory replacement or reconstruction (including but not limited to all costs of repair or replacement of work of others); and pending Contractor's full discharge of this responsibility the Owner shall be entitled to impose a reasonable set-off against payments due under Article 15.
 - 2. If the uncovered Work is not found to be defective, Contractor shall be allowed an increase in the Contract Price or an extension of the Contract Times, or both, directly attributable to such uncovering, exposure, observation, inspection, testing, replacement, and reconstruction. If the parties are unable to agree as to the amount or extent thereof, then Contractor may submit a Change Proposal within 30 days of the determination that the Work is not defective.

14.06 *Owner May Stop the Work*

- A. If the Work is defective, or Contractor fails to supply sufficient skilled workers or suitable materials or equipment, or fails to perform the Work in such a way that the completed Work will conform to the Contract Documents, then Owner may order Contractor to stop the Work, or any portion thereof, until the cause for such order has been eliminated; however, this right of Owner to stop the Work shall not give rise to any duty on the part of Owner to exercise this right for the benefit of Contractor, any Subcontractor, any Supplier, any other individual or entity, or any surety for, or employee or agent of any of them.

14.07 *Owner May Correct Defective Work*

- A. If Contractor fails within a reasonable time after written notice from Engineer to correct defective Work, or to remove and replace rejected Work as required by Engineer, or if Contractor fails to perform the Work in accordance with the Contract Documents, or if Contractor fails to comply with any other provision of the Contract Documents, then Owner may, after seven days written notice to Contractor, correct or remedy any such deficiency.
- B. In exercising the rights and remedies under this Paragraph 14.07, Owner shall proceed expeditiously. In connection with such corrective or remedial action, Owner may exclude Contractor from all or part of the Site, take possession of all or part of the Work and suspend Contractor's services related thereto, and incorporate in the Work all materials and equipment stored at the Site or for which Owner has paid Contractor but which are stored elsewhere. Contractor shall allow Owner, Owner's representatives, agents and employees, Owner's other contractors, and Engineer and Engineer's consultants access to the Site to enable Owner to exercise the rights and remedies under this paragraph.
- C. All claims, costs, losses, and damages incurred or sustained by Owner in exercising the rights and remedies under this Paragraph 14.07 will be charged against Contractor as set-offs against payments due under Article 15. Such claims, costs, losses and damages will

include but not be limited to all costs of repair, or replacement of work of others destroyed or damaged by correction, removal, or replacement of Contractor's defective Work.

- D. Contractor shall not be allowed an extension of the Contract Times because of any delay in the performance of the Work attributable to the exercise by Owner of Owner's rights and remedies under this Paragraph 14.07.

ARTICLE 15 – PAYMENTS TO CONTRACTOR; SET-OFFS; COMPLETION; CORRECTION PERIOD

15.01 Progress Payments

- A. *Basis for Progress Payments:* The Schedule of Values established as provided in Article 2 will serve as the basis for progress payments and will be incorporated into a form of Application for Payment acceptable to Engineer. Progress payments on account of Unit Price Work will be based on the number of units completed during the pay period, as determined under the provisions of Paragraph 13.03. Progress payments for cost-based Work will be based on Cost of the Work completed by Contractor during the pay period.
- B. *Applications for Payments:*
1. At least 20 days before the date established in the Agreement for each progress payment (but not more often than once a month), Contractor shall submit to Engineer for review an Application for Payment filled out and signed by Contractor covering the Work completed as of the date of the Application and accompanied by such supporting documentation as is required by the Contract Documents. If payment is requested on the basis of materials and equipment not incorporated in the Work but delivered and suitably stored at the Site or at another location agreed to in writing, the Application for Payment shall also be accompanied by a bill of sale, invoice, or other documentation warranting that Owner has received the materials and equipment free and clear of all Liens, and evidence that the materials and equipment are covered by appropriate property insurance, a warehouse bond, or other arrangements to protect Owner's interest therein, all of which must be satisfactory to Owner.
 2. Beginning with the second Application for Payment, each Application shall include an affidavit of Contractor stating that all previous progress payments received on account of the Work have been applied on account to discharge Contractor's legitimate obligations associated with prior Applications for Payment.
 3. The amount of retainage with respect to progress payments will be as stipulated in the Agreement.
- C. *Review of Applications:*
1. Engineer will, within 10 days after receipt of each Application for Payment, including each resubmittal, either indicate in writing a recommendation of payment and present the Application to Owner, or return the Application to Contractor indicating in writing Engineer's reasons for refusing to recommend payment. In the latter case, Contractor may make the necessary corrections and resubmit the Application.
 2. Engineer's recommendation of any payment requested in an Application for Payment will constitute a representation by Engineer to Owner, based on Engineer's observations of the executed Work as an experienced and qualified design professional, and on Engineer's review of the Application for Payment and the accompanying data and schedules, that to the best of Engineer's knowledge, information and belief:

- a. the Work has progressed to the point indicated;
 - b. the quality of the Work is generally in accordance with the Contract Documents (subject to an evaluation of the Work as a functioning whole prior to or upon Substantial Completion, the results of any subsequent tests called for in the Contract Documents, a final determination of quantities and classifications for Unit Price Work under Paragraph 13.03, and any other qualifications stated in the recommendation); and
 - c. the conditions precedent to Contractor's being entitled to such payment appear to have been fulfilled in so far as it is Engineer's responsibility to observe the Work.
3. By recommending any such payment Engineer will not thereby be deemed to have represented that:
 - a. inspections made to check the quality or the quantity of the Work as it has been performed have been exhaustive, extended to every aspect of the Work in progress, or involved detailed inspections of the Work beyond the responsibilities specifically assigned to Engineer in the Contract; or
 - b. there may not be other matters or issues between the parties that might entitle Contractor to be paid additionally by Owner or entitle Owner to withhold payment to Contractor.
 4. Neither Engineer's review of Contractor's Work for the purposes of recommending payments nor Engineer's recommendation of any payment, including final payment, will impose responsibility on Engineer:
 - a. to supervise, direct, or control the Work, or
 - b. for the means, methods, techniques, sequences, or procedures of construction, or the safety precautions and programs incident thereto, or
 - c. for Contractor's failure to comply with Laws and Regulations applicable to Contractor's performance of the Work, or
 - d. to make any examination to ascertain how or for what purposes Contractor has used the money paid on account of the Contract Price, or
 - e. to determine that title to any of the Work, materials, or equipment has passed to Owner free and clear of any Liens.
 5. Engineer may refuse to recommend the whole or any part of any payment if, in Engineer's opinion, it would be incorrect to make the representations to Owner stated in Paragraph 15.01.C.2.
 6. Engineer will recommend reductions in payment (set-offs) necessary in Engineer's opinion to protect Owner from loss because:
 - a. the Work is defective, requiring correction or replacement;
 - b. the Contract Price has been reduced by Change Orders;
 - c. Owner has been required to correct defective Work in accordance with Paragraph 14.07, or has accepted defective Work pursuant to Paragraph 14.04;
 - d. Owner has been required to remove or remediate a Hazardous Environmental Condition for which Contractor is responsible; or

- e. Engineer has actual knowledge of the occurrence of any of the events that would constitute a default by Contractor and therefore justify termination for cause under the Contract Documents.

D. *Payment Becomes Due:*

- 1. Ten days after presentation of the Application for Payment to Owner with Engineer's recommendation, the amount recommended (subject to any Owner set-offs) will become due, and when due will be paid by Owner to Contractor.

E. *Reductions in Payment by Owner:*

- 1. In addition to any reductions in payment (set-offs) recommended by Engineer, Owner is entitled to impose a set-off against payment based on any of the following:
 - a. claims have been made against Owner on account of Contractor's conduct in the performance or furnishing of the Work, or Owner has incurred costs, losses, or damages on account of Contractor's conduct in the performance or furnishing of the Work, including but not limited to claims, costs, losses, or damages from workplace injuries, adjacent property damage, non-compliance with Laws and Regulations, and patent infringement;
 - b. Contractor has failed to take reasonable and customary measures to avoid damage, delay, disruption, and interference with other work at or adjacent to the Site;
 - c. Contractor has failed to provide and maintain required bonds or insurance;
 - d. Owner has been required to remove or remediate a Hazardous Environmental Condition for which Contractor is responsible;
 - e. Owner has incurred extra charges or engineering costs related to submittal reviews, evaluations of proposed substitutes, tests and inspections, or return visits to manufacturing or assembly facilities;
 - f. the Work is defective, requiring correction or replacement;
 - g. Owner has been required to correct defective Work in accordance with Paragraph 14.07, or has accepted defective Work pursuant to Paragraph 14.04;
 - h. the Contract Price has been reduced by Change Orders;
 - i. an event that would constitute a default by Contractor and therefore justify a termination for cause has occurred;
 - j. liquidated damages have accrued as a result of Contractor's failure to achieve Milestones, Substantial Completion, or final completion of the Work;
 - k. Liens have been filed in connection with the Work, except where Contractor has delivered a specific bond satisfactory to Owner to secure the satisfaction and discharge of such Liens;
 - l. there are other items entitling Owner to a set off against the amount recommended.
- 2. If Owner imposes any set-off against payment, whether based on its own knowledge or on the written recommendations of Engineer, Owner will give Contractor immediate written notice (with a copy to Engineer) stating the reasons for such action and the specific amount of the reduction, and promptly pay Contractor any amount

remaining after deduction of the amount so withheld. Owner shall promptly pay Contractor the amount so withheld, or any adjustment thereto agreed to by Owner and Contractor, if Contractor remedies the reasons for such action. The reduction imposed shall be binding on Contractor unless it duly submits a Change Proposal contesting the reduction.

3. Upon a subsequent determination that Owner's refusal of payment was not justified, the amount wrongfully withheld shall be treated as an amount due as determined by Paragraph 15.01.C.1 and subject to interest as provided in the Agreement.

15.02 *Contractor's Warranty of Title*

- A. Contractor warrants and guarantees that title to all Work, materials, and equipment furnished under the Contract will pass to Owner free and clear of (1) all Liens and other title defects, and (2) all patent, licensing, copyright, or royalty obligations, no later than seven days after the time of payment by Owner.

15.03 *Substantial Completion*

- A. When Contractor considers the entire Work ready for its intended use Contractor shall notify Owner and Engineer in writing that the entire Work is substantially complete and request that Engineer issue a certificate of Substantial Completion. Contractor shall at the same time submit to Owner and Engineer an initial draft of punch list items to be completed or corrected before final payment.
- B. Promptly after Contractor's notification, Owner, Contractor, and Engineer shall make an inspection of the Work to determine the status of completion. If Engineer does not consider the Work substantially complete, Engineer will notify Contractor in writing giving the reasons therefor.
- C. If Engineer considers the Work substantially complete, Engineer will deliver to Owner a preliminary certificate of Substantial Completion which shall fix the date of Substantial Completion. Engineer shall attach to the certificate a punch list of items to be completed or corrected before final payment. Owner shall have seven days after receipt of the preliminary certificate during which to make written objection to Engineer as to any provisions of the certificate or attached punch list. If, after considering the objections to the provisions of the preliminary certificate, Engineer concludes that the Work is not substantially complete, Engineer will, within 14 days after submission of the preliminary certificate to Owner, notify Contractor in writing that the Work is not substantially complete, stating the reasons therefor. If Owner does not object to the provisions of the certificate, or if despite consideration of Owner's objections Engineer concludes that the Work is substantially complete, then Engineer will, within said 14 days, execute and deliver to Owner and Contractor a final certificate of Substantial Completion (with a revised punch list of items to be completed or corrected) reflecting such changes from the preliminary certificate as Engineer believes justified after consideration of any objections from Owner.
- D. At the time of receipt of the preliminary certificate of Substantial Completion, Owner and Contractor will confer regarding Owner's use or occupancy of the Work following Substantial Completion, review the builder's risk insurance policy with respect to the end of the builder's risk coverage, and confirm the transition to coverage of the Work under a permanent property insurance policy held by Owner. Unless Owner and Contractor agree otherwise in writing, Owner shall bear responsibility for security, operation, protection of the Work, property insurance, maintenance, heat, and utilities upon Owner's use or occupancy of the Work.

- E. After Substantial Completion the Contractor shall promptly begin work on the punch list of items to be completed or corrected prior to final payment. In appropriate cases Contractor may submit monthly Applications for Payment for completed punch list items, following the progress payment procedures set forth above.
- F. Owner shall have the right to exclude Contractor from the Site after the date of Substantial Completion subject to allowing Contractor reasonable access to remove its property and complete or correct items on the punch list.

15.04 *Partial Use or Occupancy*

- A. Prior to Substantial Completion of all the Work, Owner may use or occupy any substantially completed part of the Work which has specifically been identified in the Contract Documents, or which Owner, Engineer, and Contractor agree constitutes a separately functioning and usable part of the Work that can be used by Owner for its intended purpose without significant interference with Contractor's performance of the remainder of the Work, subject to the following conditions:
 - 1. At any time Owner may request in writing that Contractor permit Owner to use or occupy any such part of the Work that Owner believes to be substantially complete. If and when Contractor agrees that such part of the Work is substantially complete, Contractor, Owner, and Engineer will follow the procedures of Paragraph 15.03.A through E for that part of the Work.
 - 2. At any time Contractor may notify Owner and Engineer in writing that Contractor considers any such part of the Work substantially complete and request Engineer to issue a certificate of Substantial Completion for that part of the Work.
 - 3. Within a reasonable time after either such request, Owner, Contractor, and Engineer shall make an inspection of that part of the Work to determine its status of completion. If Engineer does not consider that part of the Work to be substantially complete, Engineer will notify Owner and Contractor in writing giving the reasons therefor. If Engineer considers that part of the Work to be substantially complete, the provisions of Paragraph 15.03 will apply with respect to certification of Substantial Completion of that part of the Work and the division of responsibility in respect thereof and access thereto.
 - 4. No use or occupancy or separate operation of part of the Work may occur prior to compliance with the requirements of Paragraph 6.05 regarding builder's risk or other property insurance.

15.05 *Final Inspection*

- A. Upon written notice from Contractor that the entire Work or an agreed portion thereof is complete, Engineer will promptly make a final inspection with Owner and Contractor and will notify Contractor in writing of all particulars in which this inspection reveals that the Work, or agreed portion thereof, is incomplete or defective. Contractor shall immediately take such measures as are necessary to complete such Work or remedy such deficiencies.

15.06 *Final Payment*

- A. *Application for Payment:*
 - 1. After Contractor has, in the opinion of Engineer, satisfactorily completed all corrections identified during the final inspection and has delivered, in accordance with the Contract Documents, all maintenance and operating instructions, schedules, guarantees, bonds, certificates or other evidence of insurance, certificates of

inspection, annotated record documents (as provided in Paragraph 7.11), and other documents, Contractor may make application for final payment.

2. The final Application for Payment shall be accompanied (except as previously delivered) by:
 - a. all documentation called for in the Contract Documents;
 - b. consent of the surety, if any, to final payment;
 - c. satisfactory evidence that all title issues have been resolved such that title to all Work, materials, and equipment has passed to Owner free and clear of any Liens or other title defects, or will so pass upon final payment.
 - d. a list of all disputes that Contractor believes are unsettled; and
 - e. complete and legally effective releases or waivers (satisfactory to Owner) of all Lien rights arising out of the Work, and of Liens filed in connection with the Work.
3. In lieu of the releases or waivers of Liens specified in Paragraph 15.06.A.2 and as approved by Owner, Contractor may furnish receipts or releases in full and an affidavit of Contractor that: (a) the releases and receipts include all labor, services, material, and equipment for which a Lien could be filed; and (b) all payrolls, material and equipment bills, and other indebtedness connected with the Work for which Owner might in any way be responsible, or which might in any way result in liens or other burdens on Owner's property, have been paid or otherwise satisfied. If any Subcontractor or Supplier fails to furnish such a release or receipt in full, Contractor may furnish a bond or other collateral satisfactory to Owner to indemnify Owner against any Lien, or Owner at its option may issue joint checks payable to Contractor and specified Subcontractors and Suppliers.

B. *Engineer's Review of Application and Acceptance:*

1. If, on the basis of Engineer's observation of the Work during construction and final inspection, and Engineer's review of the final Application for Payment and accompanying documentation as required by the Contract Documents, Engineer is satisfied that the Work has been completed and Contractor's other obligations under the Contract have been fulfilled, Engineer will, within ten days after receipt of the final Application for Payment, indicate in writing Engineer's recommendation of final payment and present the Application for Payment to Owner for payment. Such recommendation shall account for any set-offs against payment that are necessary in Engineer's opinion to protect Owner from loss for the reasons stated above with respect to progress payments. At the same time Engineer will also give written notice to Owner and Contractor that the Work is acceptable, subject to the provisions of Paragraph 15.07. Otherwise, Engineer will return the Application for Payment to Contractor, indicating in writing the reasons for refusing to recommend final payment, in which case Contractor shall make the necessary corrections and resubmit the Application for Payment.

C. *Completion of Work:* The Work is complete (subject to surviving obligations) when it is ready for final payment as established by the Engineer's written recommendation of final payment.

D. *Payment Becomes Due:* Thirty days after the presentation to Owner of the final Application for Payment and accompanying documentation, the amount recommended by Engineer (less any further sum Owner is entitled to set off against Engineer's recommendation,

including but not limited to set-offs for liquidated damages and set-offs allowed under the provisions above with respect to progress payments) will become due and shall be paid by Owner to Contractor.

15.07 *Waiver of Claims*

- A. The making of final payment will not constitute a waiver by Owner of claims or rights against Contractor. Owner expressly reserves claims and rights arising from unsettled Liens, from defective Work appearing after final inspection pursuant to Paragraph 15.05, from Contractor's failure to comply with the Contract Documents or the terms of any special guarantees specified therein, from outstanding Claims by Owner, or from Contractor's continuing obligations under the Contract Documents.
- B. The acceptance of final payment by Contractor will constitute a waiver by Contractor of all claims and rights against Owner other than those pending matters that have been duly submitted or appealed under the provisions of Article 17.

15.08 *Correction Period*

- A. If within one year after the date of Substantial Completion (or such longer period of time as may be prescribed by the terms of any applicable special guarantee required by the Contract Documents, or by any specific provision of the Contract Documents), any Work is found to be defective, or if the repair of any damages to the Site, adjacent areas that Contractor has arranged to use through construction easements or otherwise, and other adjacent areas used by Contractor as permitted by Laws and Regulations, is found to be defective, then Contractor shall promptly, without cost to Owner and in accordance with Owner's written instructions:
 - 1. correct the defective repairs to the Site or such other adjacent areas;
 - 2. correct such defective Work;
 - 3. if the defective Work has been rejected by Owner, remove it from the Project and replace it with Work that is not defective, and
 - 4. satisfactorily correct or repair or remove and replace any damage to other Work, to the work of others, or to other land or areas resulting therefrom.
- B. If Contractor does not promptly comply with the terms of Owner's written instructions, or in an emergency where delay would cause serious risk of loss or damage, Owner may have the defective Work corrected or repaired or may have the rejected Work removed and replaced. Contractor shall pay all claims, costs, losses, and damages (including but not limited to all fees and charges of engineers, architects, attorneys, and other professionals and all court or arbitration or other dispute resolution costs) arising out of or relating to such correction or repair or such removal and replacement (including but not limited to all costs of repair or replacement of work of others).
- C. In special circumstances where a particular item of equipment is placed in continuous service before Substantial Completion of all the Work, the correction period for that item may start to run from an earlier date if so provided in the Specifications.
- D. Where defective Work (and damage to other Work resulting therefrom) has been corrected or removed and replaced under this paragraph, the correction period hereunder with respect to such Work will be extended for an additional period of one year after such correction or removal and replacement has been satisfactorily completed.

- E. Contractor's obligations under this paragraph are in addition to all other obligations and warranties. The provisions of this paragraph shall not be construed as a substitute for, or a waiver of, the provisions of any applicable statute of limitation or repose.

ARTICLE 16 – SUSPENSION OF WORK AND TERMINATION

16.01 *Owner May Suspend Work*

- A. At any time and without cause, Owner may suspend the Work or any portion thereof for a period of not more than 90 consecutive days by written notice to Contractor and Engineer. Such notice will fix the date on which Work will be resumed. Contractor shall resume the Work on the date so fixed. Contractor shall be entitled to an adjustment in the Contract Price or an extension of the Contract Times, or both, directly attributable to any such suspension. Any Change Proposal seeking such adjustments shall be submitted no later than 30 days after the date fixed for resumption of Work.

16.02 *Owner May Terminate for Cause*

- A. The occurrence of any one or more of the following events will constitute a default by Contractor and justify termination for cause:
 - 1. Contractor's persistent failure to perform the Work in accordance with the Contract Documents (including, but not limited to, failure to supply sufficient skilled workers or suitable materials or equipment or failure to adhere to the Progress Schedule);
 - 2. Failure of Contractor to perform or otherwise to comply with a material term of the Contract Documents;
 - 3. Contractor's disregard of Laws or Regulations of any public body having jurisdiction; or
 - 4. Contractor's repeated disregard of the authority of Owner or Engineer.
- B. If one or more of the events identified in Paragraph 16.02.A occurs, then after giving Contractor (and any surety) ten days written notice that Owner is considering a declaration that Contractor is in default and termination of the contract, Owner may proceed to:
 - 1. declare Contractor to be in default, and give Contractor (and any surety) notice that the Contract is terminated; and
 - 2. enforce the rights available to Owner under any applicable performance bond.
- C. Subject to the terms and operation of any applicable performance bond, if Owner has terminated the Contract for cause, Owner may exclude Contractor from the Site, take possession of the Work, incorporate in the Work all materials and equipment stored at the Site or for which Owner has paid Contractor but which are stored elsewhere, and complete the Work as Owner may deem expedient.
- D. Owner may not proceed with termination of the Contract under Paragraph 16.02.B if Contractor within seven days of receipt of notice of intent to terminate begins to correct its failure to perform and proceeds diligently to cure such failure.
- E. If Owner proceeds as provided in Paragraph 16.02.B, Contractor shall not be entitled to receive any further payment until the Work is completed. If the unpaid balance of the Contract Price exceeds the cost to complete the Work, including all related claims, costs, losses, and damages (including but not limited to all fees and charges of engineers, architects, attorneys, and other professionals) sustained by Owner, such excess will be paid to Contractor. If the cost to complete the Work including such related claims, costs, losses,

and damages exceeds such unpaid balance, Contractor shall pay the difference to Owner. Such claims, costs, losses, and damages incurred by Owner will be reviewed by Engineer as to their reasonableness and, when so approved by Engineer, incorporated in a Change Order. When exercising any rights or remedies under this paragraph, Owner shall not be required to obtain the lowest price for the Work performed.

- F. Where Contractor's services have been so terminated by Owner, the termination will not affect any rights or remedies of Owner against Contractor then existing or which may thereafter accrue, or any rights or remedies of Owner against Contractor or any surety under any payment bond or performance bond. Any retention or payment of money due Contractor by Owner will not release Contractor from liability.
- G. If and to the extent that Contractor has provided a performance bond under the provisions of Paragraph 6.01.A, the provisions of that bond shall govern over any inconsistent provisions of Paragraphs 16.02.B and 16.02.D.

16.03 *Owner May Terminate For Convenience*

- A. Upon seven days written notice to Contractor and Engineer, Owner may, without cause and without prejudice to any other right or remedy of Owner, terminate the Contract. In such case, Contractor shall be paid for (without duplication of any items):
 - 1. completed and acceptable Work executed in accordance with the Contract Documents prior to the effective date of termination, including fair and reasonable sums for overhead and profit on such Work;
 - 2. expenses sustained prior to the effective date of termination in performing services and furnishing labor, materials, or equipment as required by the Contract Documents in connection with uncompleted Work, plus fair and reasonable sums for overhead and profit on such expenses; and
 - 3. other reasonable expenses directly attributable to termination, including costs incurred to prepare a termination for convenience cost proposal.
- B. Contractor shall not be paid on account of loss of anticipated overhead, profits, or revenue, or other economic loss arising out of or resulting from such termination.

16.04 *Contractor May Stop Work or Terminate*

- A. If, through no act or fault of Contractor, (1) the Work is suspended for more than 90 consecutive days by Owner or under an order of court or other public authority, or (2) Engineer fails to act on any Application for Payment within 30 days after it is submitted, or (3) Owner fails for 30 days to pay Contractor any sum finally determined to be due, then Contractor may, upon seven days written notice to Owner and Engineer, and provided Owner or Engineer do not remedy such suspension or failure within that time, terminate the contract and recover from Owner payment on the same terms as provided in Paragraph 16.03.
- B. In lieu of terminating the Contract and without prejudice to any other right or remedy, if Engineer has failed to act on an Application for Payment within 30 days after it is submitted, or Owner has failed for 30 days to pay Contractor any sum finally determined to be due, Contractor may, seven days after written notice to Owner and Engineer, stop the Work until payment is made of all such amounts due Contractor, including interest thereon. The provisions of this paragraph are not intended to preclude Contractor from submitting a Change Proposal for an adjustment in Contract Price or Contract Times or otherwise for

expenses or damage directly attributable to Contractor's stopping the Work as permitted by this paragraph.

ARTICLE 17 – FINAL RESOLUTION OF DISPUTES

17.01 *Methods and Procedures*

- A. *Disputes Subject to Final Resolution:* The following disputed matters are subject to final resolution under the provisions of this Article:
 - 1. A timely appeal of an approval in part and denial in part of a Claim, or of a denial in full; and
 - 2. Disputes between Owner and Contractor concerning the Work or obligations under the Contract Documents, and arising after final payment has been made.
- B. *Final Resolution of Disputes:* For any dispute subject to resolution under this Article, Owner or Contractor may:
 - 1. elect in writing to invoke the dispute resolution process provided for in the Supplementary Conditions; or
 - 2. agree with the other party to submit the dispute to another dispute resolution process; or
 - 3. if no dispute resolution process is provided for in the Supplementary Conditions or mutually agreed to, give written notice to the other party of the intent to submit the dispute to a court of competent jurisdiction.

ARTICLE 18 – MISCELLANEOUS

18.01 *Giving Notice*

- A. Whenever any provision of the Contract Documents requires the giving of written notice, it will be deemed to have been validly given if:
 - 1. delivered in person, by a commercial courier service or otherwise, to the individual or to a member of the firm or to an officer of the corporation for which it is intended; or
 - 2. delivered at or sent by registered or certified mail, postage prepaid, to the last business address known to the sender of the notice.

18.02 *Computation of Times*

- A. When any period of time is referred to in the Contract by days, it will be computed to exclude the first and include the last day of such period. If the last day of any such period falls on a Saturday or Sunday or on a day made a legal holiday by the law of the applicable jurisdiction, such day will be omitted from the computation.

18.03 *Cumulative Remedies*

- A. The duties and obligations imposed by these General Conditions and the rights and remedies available hereunder to the parties hereto are in addition to, and are not to be construed in any way as a limitation of, any rights and remedies available to any or all of them which are otherwise imposed or available by Laws or Regulations, by special warranty or guarantee, or by other provisions of the Contract. The provisions of this paragraph will be as effective as if repeated specifically in the Contract Documents in connection with each particular duty, obligation, right, and remedy to which they apply.

18.04 *Limitation of Damages*

- A. With respect to any and all Change Proposals, Claims, disputes subject to final resolution, and other matters at issue, neither Owner nor Engineer, nor any of their officers, directors, members, partners, employees, agents, consultants, or subcontractors, shall be liable to Contractor for any claims, costs, losses, or damages sustained by Contractor on or in connection with any other project or anticipated project.

18.05 *No Waiver*

- A. A party's non-enforcement of any provision shall not constitute a waiver of that provision, nor shall it affect the enforceability of that provision or of the remainder of this Contract.

18.06 *Survival of Obligations*

- A. All representations, indemnifications, warranties, and guarantees made in, required by, or given in accordance with the Contract, as well as all continuing obligations indicated in the Contract, will survive final payment, completion, and acceptance of the Work or termination or completion of the Contract or termination of the services of Contractor.

18.07 *Controlling Law*

- A. This Contract is to be governed by the law of the state in which the Project is located.

18.08 *Headings*

- A. Article and paragraph headings are inserted for convenience only and do not constitute parts of these General Conditions.

SECTION 00810

SUPPLEMENTAL CONDITIONS

Unless otherwise noted, all paragraphs are additive to similarly numbered paragraphs in SECTION 00700 – GENERAL CONDITIONS. These Supplementary Conditions amend or supplement the Standard General Conditions of the Construction Contract (EJCDC C-700, 2013, Rev1 Edition) and other provisions of the Contract Documents as indicated below. All provisions which are not so amended or supplemented remain in full force and effect.

The terms used in these Supplementary Conditions have the meanings indicated in the General Conditions. Additional terms used in these Supplementary Conditions have the meanings indicated below, which are applicable to both the singular and plural thereof.

PART I AMENDMENTS TO GENERAL CONDITIONS

Article No.

- | | |
|------|--|
| 1.0 | DEFINITIONS AND TERMINOLOGY |
| 2.0 | PRELIMINARY MATTERS |
| 3.0 | DOCUMENTS: INTENT, REQUIREMENTS AND REUSE |
| 4.0 | COMMENCEMENT AND PROGRESS OF WORK |
| 5.0 | AVAILABILITY OF LANDS; SUBSURFACE AND PHYSICAL CONDITIONS;
HAZARDOUS ENVIRONMENTAL CONDITIONS |
| 6.0 | BONDS AND INSURANCE |
| 7.0 | CONTRACTOR'S RESPONSIBILITIES |
| 8.0 | OTHER WORK AT THE SITE |
| 9.0 | OWNERS RESPONSIBILITIES |
| 10.0 | ENGINEER'S STATUS DURING CONSTRUCTION |
| 11.0 | AMMENDING CONTRACT DOCUMENTS: CHANGES IN WORK |
| 12.0 | CLAIMS |
| 13.0 | COST OF WORK:ALLOWANCES: UNIT PRICE WORK |
| 14.0 | TEST AND INSPECTIONS |
| 15.0 | PAYMENTS TO CONTRACTOR |
| 16.0 | SUSPENSION OF WORK AND TERMINATION |
| 17.0 | FINAL RESOLUTION OF DISPUTES |
| 18.0 | MISCELLANEOUS |

PART II ADDITIONS TO GENERAL CONDITIONS

PART III STATE AND FEDERAL GOVERNMENT PROVISIONS

PART I AMENDMENTS TO GENERAL CONDITIONS

1.0 DEFINITIONS AND TERMINOLOGY

- A. The following language shall be added at the beginning of the definition entitled “Contract Documents” in the General Conditions (1.01.A.13).

“The Invitation to Bid, Instructions to Bidders”

- B. 1.01.A.18, Add the words “or plans” after the word “drawings in the first line of the definition entitled “Drawings” in the General Conditions.

- C. 1.01.A.38, Delete the definition of Specifications in the General Conditions in its entirety and add the following in its place:

“Sections included under Division 1 through Division 16 of the Contract Documents”

- D. 1.01.A.40 The definition of Substantial Completion shall be deleted in the General Conditions in its entirety and add the following in its place:

Substantial completion shall mean either that the work required by the Contract has been completed except for work having a contract price of less than one percent of the then adjusted total contract price, or substantially all of the work has been completed and opened to Owner’s use except for minor incomplete or unsatisfactory work items that do not materially impair the usefulness of the work required by the Contract.

- E. The following new definitions shall be added at the end of Article 1 of the General Conditions:

Conditions of the Contract–The combined General Conditions and Supplementary Conditions.

Engineer – GCG Associates, Inc., 84 Main Street, Wilmington, MA, 01887, said corporation to be considered an agent of the Owner.

Site – The specific area adjacent to and including the area upon which the construction work is performed.

2.0 PRELIMINARY MATTERS

- A. Delete paragraph 2.03A in its entirety and insert in its place:

2.03. A: Contract time will commence on the date specified in the Notice to Proceed.

3.0 DOCUMENTS: INTENT, REQUIREMENTS AND REUSE

Four paragraphs shall be added immediately after paragraph 3.01.E of the General Conditions which is to read as follows:

3.01.F. Each and every provision of law and clause required by law to be inserted in these Contract Documents shall be deemed to be inserted herein, and they shall be read and enforced as though it were included herein, and if through mistake or otherwise, any such provision is not inserted, or if not correctly inserted, then upon the application of either party, the Contract Documents shall forthwith be physically amended to make such insertion.

3.01.G. Contract Documents shall forthwith be physically amended to make such insertion.

3.01.H. In case of any discrepancy between these Conditions of the Contract and any Federal Government provisions, the Federal Government provision shall prevail.

3.01.I. In case of any discrepancy between these between these Conditions of the Contract and any Commonwealth of Massachusetts provisions, the Commonwealth of Massachusetts provision shall prevail.

3.01.J In the event of conflicts, inconsistencies or discrepancies among the Contract Documents, to the extent applicable, the better quality or greater quantity of work shall be provided without change to the Contract Price. In the event of such conflicts, inconsistencies or discrepancies which do not relate to the quality or quantity of work, the Contractor shall request clarifications or interpretations from the Engineer as provided in Article 10.

5.0 AVAILABILITY OF LANDS; SUBSURFACE AND PHYSICAL CONDITIONS; HAZARDOUS ENVIRONMENTAL CONDITIONS

A. A new paragraph shall be added immediately after paragraph 5.01.C of the General Conditions which is to read as follows:

D. If all lands and rights-of-way are not obtained as herein contemplated before construction begins, the Contractor shall begin the work upon such land and rights-of-way as the Owner has previously acquired and no claim for damages whatsoever will be allowed by reason of the delay in obtaining the remaining lands and rights-of-way. Should the Owner be prevented or enjoined from proceeding with the work, or from authorizing its prosecution, either before or after the commencement, by reason of any litigation, or by reason of its inability to procure any lands or rights-of-way for work, Contractor shall not be entitled to make or assert claim for the damage by reason of said delay, or to withdraw from the Agreement except by consent of the Owner. Time for

completion of the work will be extended as provided in Article 11, to such time as the Owner determines will compensate for the time lost by such delay.

- B. A new paragraph shall be added immediately after paragraph 5.03.B of the General Conditions which is to read as follows (if borings performed):

5.03.C. The Engineer has relied upon the data obtained from subsurface investigations made at the site in the form of test borings and probes. Such data is in the form of logs which are included in the Section 00220 and soil samples which may be examined at the Engineer's office during regular business hours. The locations of the test borings and probes are indicated on the Drawings. Such logs and samples are not part of the Contract Documents.

- C. Two new paragraphs shall be added immediately after paragraph 5.05.E of the General Conditions which is to read as follows:

5.05.F. Information on Drawings and any statements of the Contract Documents referring to the conditions under which the work is to be performed or the existence of utilities or other underground structures are not guaranteed to be correct or to be complete representation of all existing data with reference to conditions affecting the work. Efforts have been made however, to make this information complete and accurate on the basis of all data and information which could be procured by Engineer. If, in the opinion of Engineer, permanent relocation of a utility not otherwise provided for, is required, he shall direct the Contractor, in writing, to perform the work. Work, so directed, will be paid as provided in Article 11 of the General Conditions.

5.05.G. Adjustments resulting from subsurface or latent physical conditions will be in accordance with Massachusetts General Law, Chapter 30, Section 39N.

6.0 BONDS AND INSURANCE CONTRACTOR'S (AND SUBCONTRACTOR'S) PUBLIC LIABILITY, PROPERTY DAMAGE AND VEHICLE LIABILITY INSURANCE

The following shall be added to 6.0.

- A. The liability limits for the insurance required by the General Conditions shall provide coverage for not less than the following amounts or greater where required by law:

The Contractor shall purchase and maintain such insurance as will protect him for claims set forth herein which may arise out of or result from the Contractor's operations be by himself or by any subcontractor or by anyone directly or indirectly employed by any of them, or by anyone for whose acts any of them are liable.

1. Claims under workman's compensation, disability benefit and other similar employee benefit and other similar employee benefit acts;

2. Claims for damages because of bodily injury, occupational sickness or disease, or death of his employees;
3. Claims for damages because of bodily injury, sickness or disease, or death of any person other than his employees;
4. Claims for damages insured by usual personal injury liability coverage which are sustained (1) by any person as a result of an offense directly or indirectly related to the employment of such person by the Contractor, or (2) by any other person; and
5. Claims for damages because of injury to or destruction of tangible property, including loss of use resulting therefrom.

- B. The required insurance shall be written for not less than the following limits of liability, or as required by law, whichever is greater.

The work shall be entirely at the contractor's risk until the same is fully completed and accepted, and he will be held liable to the amount of the City's interest in the same as shown by payments account.

The contractor shall, during the progress of the work, maintain insurance on all work included in the contract until the final or conditional acceptance of the work. **The City shall be named as an additional insured on all insurance.** Failure to provide and continue in force such insurance as specified shall be deemed a material breach of the contract and shall operate as an immediate termination thereof.

A contractor shall not commence work under any contract until he has obtained all insurance required, nor shall the contractor allow any subcontractor to commence work on a sub-contract until all similar insurance required has been obtained.

1. Workmen's Compensation Insurance

The contractor will maintain, during the life of the contract, the statutory Worker's Compensation and Employer's Liability for all employees to be engaged in work on the project under the contract and in case any such work is sublet. The contract shall require the sub-contractor similarly to provide Worker's Compensation and Employer's Liability Insurance for all employees engaged in the project.

2. Automobile Bodily Injury and Property Damage

There shall be provided insurance for not less than \$1,000,000 for injuries, including wrongful death, to any one person, \$3,000,000 aggregate. Any one accident shall be covered to a limit of \$1,000,000 bodily injury each

occurrence, \$3,000,000 aggregate. There shall be property damage insurance provided to the amount of \$1,000,000 on account of any one accident and included owned, hired and non-owned automobiles.

3. Comprehensive General Liability

The contractor shall purchase and maintain such insurance as required to protect the owner's interest for the duration of the contract and until acceptance of the work.

Comprehensive General Liability Coverage covering bodily injury and property damage with limits of \$1,000,000 each occurrence, \$3,000,000 aggregate, shall include coverage for premises, operations XCU included, products completed operations, contractual insurance, brand form property damage, independent contractor's personal injury coverages.

4. Property Coverage

For materials and supplies being transported by the contractor.

5. Umbrella Liability

\$3,000,000/occurrence, \$3,000,000 aggregate.

C. The Contractor shall procure and maintain Owner's Protective Liability Insurance as herein specified.

6. In addition to the Owner the Engineer shall be named as an inseree under the Owner's Protective Liability Insurance.

7. Said policy shall provide that the coverage afforded thereby, shall be primary coverage to the full limit of liability state in the declarations, and if said Owner and its officers, agents and employees or the Engineer have other insurance against the loss covered by said policy, that other insurance shall be excess insurance only.

8. The original and one certified copy of the policy specified shall be forwarded to the Engineer for the Owner prior to commencement of any work.

9. The limits of Owner's Protective Liability Insurance shall be not less than One Million Dollars (\$1,000,000) on account of any one accident and Three Million Dollars (\$3,000,000) on account of all accidents.

D. The Contractor's and Subcontractor's insurance shall provide adequate protection against the following special hazards:

1. Blasting or explosion

2. Collapse of trench walls and underground damage
 3. Use of all equipment and tools
- E. The Contractor shall not commence work under this Contract until he has obtained all insurance required hereunder and such insurance has been approved by the Owner, nor shall the Contractor allow any subcontractor to commence work on his subcontract until all insurance required of subcontractor has been so obtained and approved. Approval of insurance required under this article shall be kept in force during the life of the Contract.
1. Certificates in triplicate of all General Contractor's policies specified shall be filed with the Engineer for the Owner. Any certificates filed with the Engineer which shall be found to be incomplete or not according to form will be returned as unsatisfactory. Rejected certificates of insurance and copies of policies shall be corrected as necessary and resubmitted until approved.
- F. Each and every policy shall contain an endorsement stating that the Insurance Company will to, prior to completion of project or any policy expiration date shown on policy and certificate, whichever occurs first, terminate policy or change any coverage therein without first mailing by registered mail, written notice of such action at least fifteen (15) days prior to termination or change, to Owner at whose request policy and certificates are issued.
- G. Delete paragraph 6.05 of the General Conditions in its entirety.
- H. Delete paragraph 6.06 of the General Conditions in its entirety.
- I. Delete paragraph 6.07 of the General Conditions in its entirety.
- J. The following new paragraphs shall be added immediately after paragraph 6.07 of the General Conditions which is to read as follows:
- 6.08. The Contractor may purchase and maintain excess liability insurance in the umbrella form in order to satisfy the limits of liability required for the insurance to be purchased and maintained in accordance with the general conditions in the form of a certificate indicating the policy numbers and limits of liability of all underlying insurance. The umbrella liability insurance shall have a combined single limit of not less than \$3,000,000. Such insurance shall contain a provision that the coverage afforded will not be cancelled or materially changed until at least thirty days prior written notice has been given to Owner.
- 6.09. If the aggregate limits of liability indicated in the Contractor's insurance provided in accordance with above limits is not sufficient to cover all claims for damages arising from his operations under this contract and from any other work performed by him or if policies of insurance do not provide that the aggregate limits of liability for bodily injury and property damage apply to each

contract or project separately, Contractor shall have such policies amended so that the aggregate limits of liability required by this Contract will be available to cover all claims for damages due to operations under this Contract.

6.10 PROOF OF CARRIAGE OF INSURANCE

Policies shall contain a clause automatically extending date of expiration to coincide with any extended date of completion granted under the Contract.

6.11 OWNER'S PROTECTIVE LIABILITY INSURANCE

The Engineer shall be named as an insuree under the Owner's Protective Liability Insurance.

Said policy shall provide that the coverage afforded thereby shall provide that the coverage afforded thereby shall be primary coverage to the full limit of liability stated in the declarations, and if said Owner and its officers, agents and employees or the Engineer have other insurance against the loss covered by said policy, that other insurance shall be excess insurance only.

CONTRACTOR'S RESPONSIBILITIES

- A. The following new paragraphs shall be inserted immediately after paragraph 7.02.B of the General Conditions.
- C. This Agreement is subject to the applicable provisions of the Contract Work Hours and Safety Standards Act, Public Law 87-581, 87th Congress. No Contractor or subcontractor contracting for any part of the work shall require or permit any laborer or mechanic to be employed on the work in excess of eight hours in any calendar day or in excess of forty hours in any work week unless such laborer or mechanic receives compensation at a rate not less than one and one-half times his basic rate of pay for all hours worked in excess of eight hours in any calendar day or in excess of forty hours in such work week, as the case may be.
- D. Except as may be otherwise required by law, all claims and disputes pertaining to the classification of labor employed on the project under this Contract shall be decided by the Owner's governing body or other duly designated official.
- E. The Contractor shall employ only competent men to do the work and whenever the Owner shall notify Contractor, in writing, that any man on the work appears to be incompetent, unfaithful, disorderly, or otherwise unsatisfactory, such man shall be removed from the project and shall not again be employed on it except with the consent of the Owner.
- F. The Contractor and all subcontractors shall, insofar as practicable, give preference in the hiring of workers for the project to qualified local residents

with first preference being given to citizens of the United States who have served in the armed forces of the United States and have been honorably discharged therefrom or released from active duty therein.

G. The Contractor and all subcontractors shall pay to all laborers and mechanics employed for the construction covered by this contract the minimum rates of pay as determined by the Secretary of Labor in accordance with the Act of March 3, 1931, as amended, known as the Davis-Bacon Act (40 U.S.C. 276a through 276a-7). Furthermore, the Contractor and subcontractors shall adhere to the stipulations and provisions published by the Secretary of Health, Education, and Welfare in "Labor Standards (Federal Water Pollution Control Act)". The Wage Rate Schedule as prepared by the Secretary of Labor and the "Labor Standards" are part of this Contract and are included in Part II of these Supplementary Conditions.

H. The Contractor and all subcontractors shall comply with the Regulations of the Secretary of Labor made pursuant to the Anti-Kickback Act of June 30, 1940 (40 U.S.C. 276c) and all amendments or modifications thereto. The Contractor and all subcontractors shall furnish the Owner with weekly Statements of Compliance. In case of subcontracts, the Contractor shall cause appropriate provision to be inserted in all subcontracts for the work which he may let to insure compliance with said Anti-Kickback Act by all subcontractors subject thereto, and Contractor shall be responsible for the submission of all Statements of Compliance required by subcontractors by said Anti-Kickback Act except as the Secretary of Labor may specifically provide for reasonable limitations, variations, and exemptions from the requirements thereof. These Regulations are part of this Contract and are included in Part II of these Supplemental Conditions.

- B. Paragraph 7.06.A of the General Conditions shall be deleted in its entirety and insert the following in its place:

7.06.A The Contractor shall not employ any subcontractor, supplier or other person or organization, (including those who are to furnish the principal items of materials or equipment), whether initially or as a substitute, against whom Owner or Engineer may have reasonable objection. Acceptance of any subcontractor, other person or organization by the Owner shall not constitute a waiver of any right of Owner to reject defective work. The Contractor shall not be required to employ any subcontractor, other person or organization against whom the Contractor has reasonable objection.

- C. The following language shall be added at the end of paragraph 7.09 of the General Conditions:

7.09.B. Except as required otherwise by Massachusetts General Law Chapter 149, Section 44F.

The materials and supplies to be used in the work of this contract are exempt from the Sales and Use Tax of the Commonwealth of Massachusetts. The Contractor shall obtain the proper certificates, maintain the necessary records and otherwise comply with the requirements of Chapter 14 of the Acts of 1966 and any amendments thereto.

- F. The following language shall be added at the end of paragraph 7.12.G of the General Conditions:

7.12H. In the event of temporary suspension of the work, or during inclement weather, or whenever the Engineer may direct; the Contractor shall, and shall cause Subcontractors, to protect carefully the work and materials against damage or injury from the weather. If, in the opinion of the Engineer, any portion of work or materials shall have been damaged or injured by reason of failure on the part of the Contractor or any subcontractors to so protect the work, such work and materials shall be removed and replaced at the expense of the Contractor.

- J. A new paragraph shall be added immediately after paragraph 7.19.E of the General Conditions which is to read as follow:

7.19.F The Contractor shall comply with all applicable provisions of Chapter 30, Section 39R of the Massachusetts General Laws regarding Contractor's records. This requirement primarily provides for the Contractor to maintain for at least six years after final payment books, records, and accounts in reasonable detail, available for examination. This requirement further provides for the Contractor to document and submit descriptions and reasons for any changes in record keeping methods, and to prepare and submit annual financial statements.

10.0 ENGINEER'S STATUS DURING CONSTRUCTION

A new paragraph shall be added immediately after paragraph 10.09 of the General Conditions which is to read as follows:

10.10 The Engineer's interpretations will be made in accordance with Massachusetts General Law Chapter 30, Section 39P which is included in Part II of the ADDITIONAL ARTICLES.

15.0 PAYMENTS TO CONTRACTORS AND COMPLETION

A new Paragraph 15.09 of the General Conditions shall be added after 15.08.

15.09 Progress Payments will be made in accordance with Massachusetts General Law, Chapter 30, Section 39G. Retainage shall be 5%, in accordance with M.G.L., Chapter 30, Section 39G.

15.10. If, after 60 days following submission of a monthly payment estimate for pipe and fitting items, the pipe and fittings for which payment is requested has not been successfully tested, the Owner may withhold up to 10% of the amount requested for such pipe and fitting items until the pipe has been so tested, however, in the case of a major (pipe diameter 24 inches or greater) pipe and fitting installation, sums retained by the Owner pursuant to this paragraph shall not exceed two percent (2%) of the costs of such pipe items. This retainage shall be in addition to any other retainage required by this Contract.

The Contractor shall make payments to subcontractors in accordance with Massachusetts General Law, Chapter 30, Section 39F which is included in ADDITIONAL ARTICLES.

15.11. If, on the basis of the Engineer's observation of the work during construction and final inspection, and Engineer's review of the final Application for Payment and accompanying documentation – all as required by the Contract Documents, Engineer is satisfied that the work has been completed and the Contractor's other obligations under the Contract Documents have been fulfilled, the Engineer will indicate in writing his recommendation of payment and present the Application to the Owner for payment. Thereupon the Engineer will give written notice to the Owner and the Contractor that the work is acceptable subject to the provisions of paragraph 14.16. Otherwise, the Engineer will return the Application to the Contractor, indicating in writing the reasons for refusing to recommend final payment, in which case the Contractor shall make the necessary corrections and resubmit the Application. If the Applications and accompanying documentation are appropriate as to form and substance, Owner shall in accordance with the applicable Massachusetts General Law, pay Contractor the amount recommended by Engineer.

15.12. Final payment will be reduced by excessive costs of plant inspection of pipe; the Contractor shall have no claim thereto. Excessive inspection costs are defined as the costs of inspection of that amount of pipe which exceeds 125 percent of the aggregate length of each type installed.

16.0 SUSPENSION OF WORK AND TERMINATION

Paragraph 16.01 of the General Conditions shall be deleted in its entirety and insert the following in its place:

16.01. The Owner may order, at any time and without cause, suspension of the work in accordance with Massachusetts General Law, Chapter 30, Section 39O.

17.0 DISPUTE AND RESOLUTION

Article 17 of the General Conditions shall be deleted in its entirety.

MISCELLANEOUS

A new paragraph shall be added immediately after paragraph 18.08 of the General Conditions which is to read as follows:

18.09. Both the address given in the Bid Form upon which this Agreement is founded, and the Contractor's office at or near the site of the work are hereby designated as places to either of which notices, letters, and other communications to the Contractor shall be certified, mailed, or delivered. The delivering at the above named place, or depositing in a postpaid wrapper directed to the first-named place, in any post office box regularly maintained by the post office department, if any notice, letter or other communication to the Contractor shall be deemed sufficient service thereof upon the Contractor: and the date of said service shall be the date of such delivery or mailing. The first-named address may be changed at any time by an instrument in writing, executed and acknowledged by the Contractor, and delivered to the Owner and shall be deemed to preclude or render inoperative the service of any notice, letter, or other communications upon the Contractor personally.

WAGE RATES

The following 4 new paragraphs shall be added immediately after paragraph 18.09 of the General Conditions:

18.10. The requirements and provisions of all applicable laws and any amendments thereof or additions thereto as to the employment of labor, and to the schedule of minimum wage rates established in compliance with laws shall be part of these Contract Documents. Copies of the wage schedule are included in Section 00820. If, after the Notice of Award, it becomes necessary to employ any person in a trade or occupation not classified in the wage determinations, such approved minimum rate shall be paid at not less than such rates as shall be determined by the officials administering the laws mentioned above. Such approved minimum rate shall be retroactive to the time of the initial employment of such person in such trade or occupation. The Contractor shall notify the Owner of his intention to employ persons in trades or occupations not classified in sufficient time for Owner to obtain approved rates for such trades or occupations.

- A. The schedules of wages referred to above are minimum rates only, and the Owner will not consider any claims for additional compensations made by the Contractor of any wage rate in excess of the applicable rate contained in these Contract Documents. All disputes in regard to the payment of wages in excess of these specified in the schedules shall be adjusted by Contractor.
- B. The said schedules of wages shall continue to be the minimum rates to be paid during the life of this Agreement and a legible copy of said schedules shall be kept posted in a conspicuous place at the site of the

work. Minimum Wage Rates as determined by the Commissioner of the Department of Labor and Industries, apply to this project. It is the responsibility of the Contractor, before bid opening, to request if necessary, any additional information on Minimum Wage Rates for those trades people who are not covered by this schedule of wage rates, but who may be employed for the proposed work under this Contract.

- C. State schedules of minimum wage rates are included in Section 00820 – ADDITIONAL ARTICLES. Where rates differ, the higher rates shall apply as a minimum for that trade.

PART 2 ADDITIONS TO GENERAL CONDITIONS

None this Contract

PART 3 STATE AND FEDERAL GOVERNMENT PROVISIONS

State and Federal Government Provisions are included in Section 00820 and selected from those to which specific references have been made elsewhere in the Contract Documents. Each and every other provision of law or clause required by law to be inserted in this Contract shall be deemed to be also inserted in herein.

- 1.0. COMMONWEALTH OF MASSACHUSETTS AND FEDERAL PROVISIONS
- 1.1. The Owner and Contractor agree that the following Commonwealth of Massachusetts and Federal Provisions apply to the Work to be performed under this Contract and that these provisions of this Contract and that these provisions supersede any conflicting provisions of this Contract.
- 1.2. Supplemental Equal Employment Opportunity Anti-Discrimination and Affirmative Action Program.
- 1.3. Massachusetts General Laws
 - 1.3.1. Chapter 30, Section 39F
 - 1.3.2. Chapter 30, Section 39G
 - 1.3.3. Chapter 30, Section 39M
 - 1.3.4. Chapter 30, Section 39N
 - 1.3.5. Chapter 30, Section 39O
 - 1.3.6. Chapter 30, Section 39P
 - 1.3.7. Chapter 30, Section 39R
 - 1.3.8. Acts of 1983 Chapter 353
- 1.4. All documents in section 00500 – Agreement and additional Contract Documents

END OF SECTION

DOCUMENT 00811
SPECIAL PROVISIONS
MONTHLY PRICE ADJUSTMENT FOR HOT MIX ASPHALT (HMA) MIXTURES
ENGLISH AND METRIC UNITS
Revised: 07/08/2016

This provision applies to all projects using greater than 100 tons (91 megagrams) of hot mix asphalt (HMA) mixtures containing liquid asphalt cement as stipulated in the Notice to Contractors section of the bid documents.

Price Adjustments will be based on the variance in price, for the liquid asphalt component only, between the Base Price and the Period Price. They shall not include transportation or other charges. Price Adjustments will occur on a monthly basis.

Base Price

The Base Price of liquid asphalt on a project as listed in the Notice to Contractors section of the bid documents is a fixed price determined by the Department at the time of the bid using the same method as the determination of the Period Price detailed below. The Base Price shall be used in all bids.

Period Price

The Period Price is the price of liquid asphalt for each monthly period as determined by the Department using the average selling price per standard ton of PG64-28 paving grade (primary binder classification) asphalt, FOB manufacturer's terminal, as listed under the "East Coast Market - New England, Boston, Massachusetts area" section of the Poten & Partners, Inc. "Asphalt Weekly Monitor". This average selling price is listed in the issue having a publication date of the second Friday of the month and will be posted as the Period Price for that month. The Department will post this Period Price on its website at <http://www.mhd.state.ma.us/> within two (2) business days following its receipt of the relevant issue of the "Asphalt Weekly Monitor". Poten and Partners has granted the Department the right to publish this specific asphalt price information sourced from the Asphalt Weekly Monitor. This method of period price determination was formerly called the New Asphalt Period Price Method. Separate website postings using both the New Asphalt Period Price Method and the Old Asphalt Period Price Method were discontinued after June 2013.

Price Adjustment Determination, Calculation and Payment

The Contract Price of the HMA mixture will be paid under the respective item in the Contract. Price Adjustments, as herein provided, either upwards or downwards, will be made after the work has been performed using the monthly period price for the month during which the work was performed.

Price Adjustments will be paid only if the variance from the Base Price is 5% or more for a monthly period. The complete adjustment will be paid in all cases with no deduction of the 5% from either upward or downward adjustments.

The Price Adjustment applies only to the actual virgin liquid asphalt content in the mixture placed on the job in accordance with the Standard Specifications for Highways and Bridges, Division III, Section M3.11.03.

Price Adjustments will be separate payment items. The pay item numbers are 999.401 for a positive price adjustment (a payment) and 999.402 for a negative price adjustment (a deduction). Price Adjustments will be calculated using the following equation:

$$\text{Price Adjustment} = \text{Tons of HMA Placed} \times \text{Liquid Asphalt Content \%} \times \text{RAP Factor} \times (\text{Period Price} - \text{Base Price})$$

No Price Adjustment will be allowed beyond the Completion Date of this Contract, unless there is a Department-approved extension of time.

***** END OF DOCUMENT *****

DOCUMENT 00812

SPECIAL PROVISIONS
MONTHLY PRICE ADJUSTMENT FOR DIESEL FUEL AND GASOLINE –
ENGLISH UNITS

Revised: 01/26/2009

This monthly fuel price adjustment is inserted in this contract because the national and worldwide energy situation has made the future cost of fuel unpredictable. This adjustment will provide for either additional compensation to the Contractor or repayment to the Commonwealth, depending on an increase or decrease in the average price of diesel fuel or gasoline.

This adjustment will be based on fuel usage factors for various items of work developed by the Highway Research Board in Circular 158, dated July 1974. These factors will be multiplied by the quantities of work done in each item during each monthly period and further multiplied by the variance in price from the Base Price to the Period Price.

The Base Price of Diesel Fuel and Gasoline will be the price as indicated in the Department's web site (www.mhd.state.ma.us) for the month in which the contract was bid, which includes State Tax.

The Period Price will be the average of prices charged to the State, including State Tax for the bulk purchases made during each month.

This adjustment will be effected only if the variance from the Base Price is 5% or more for a monthly period. The complete adjustment will be paid in all cases with no deduction of the 5% from either upward or downward adjustments.

No adjustment will be paid for work done beyond the extended completion date of any contract.

Any adjustment (increase or decrease) to estimated quantities made to each item at the time of final payment will have the fuel price adjustment figured at the average period price for the entire term of the project for the difference of quantity.

The fuel price adjustment will apply only to the following items of work at the fuel factors shown:

ITEMS COVERED	FUEL FACTORS	
	Diesel	Gasoline
Excavation: and Borrow Work: Items 120, 120.1, 121, 123, 124, 125, 127, 129.3, 140, 140.1, 141, 142, 143, 144., 150, 150.1, 151 and 151.1 (Both Factors used)	0.29 Gallons / CY.	0.15 Gallons / CY
Surfacing Work: All Items containing Hot Mix Asphalt	2.90 Gallons / Ton	Does Not Apply

***** END OF DOCUMENT *****

DOCUMENT 00813

SPECIAL PROVISIONS

PRICE ADJUSTMENTS FOR STRUCTURAL STEEL AND REINFORCING STEEL

October 11, 2018

This special provision applies to all projects containing the use of structural steel and/or reinforcing steel as specified elsewhere in the Contract work. It applies to all structural steel and all reinforcing steel, as defined below, on the project. Compliance with this provision is mandatory, i.e., there are no “opt-in” or “opt-out” clauses. Price adjustments will be handled as described below and shall only apply to unfabricated reinforcing steel bars and unfabricated structural steel material, consisting of rolled shapes, plate steel, sheet piling, pipe piles, steel castings and steel forgings, and.

Price adjustments will be variances between Base Prices and Period Prices. Base Prices and Period Prices are defined below.

Price adjustments will only be made if the variances between Base Prices and Period Prices are 5% or more. A variance can result in the Period Price being either higher or lower than the Base Price. Once the 5% threshold has been achieved, the adjustment will apply to the full variance between the Base Price and the Period Price.

Price adjustments will be calculated by multiplying the number of pounds of unfabricated structural steel material or unfabricated reinforcing steel bars on a project by the index factor calculated as shown below under Example of a Period Price Calculation.

Price adjustments will *not* include guardrail panels or the costs of shop drawing preparation, handling, fabrication, coatings, transportation, storage, installation, profit, overhead, fuel costs, fuel surcharges, or other such charges not related to the cost of the unfabricated structural steel and unfabricated reinforcing steel.

The weight of steel subject to a price adjustment shall not exceed the final shipping weight of the fabricated part by more than 10%.

Base Prices and Period Prices are defined as follows:

Base Prices of unfabricated structural steel and unfabricated reinforcing steel on a project are fixed prices determined by the Department and found in the table below. While it is the intention of the Department to make this table comprehensive, some of a project’s unfabricated structural steel and/or unfabricated reinforcing steel may be inadvertently omitted. Should this occur, the Contractor shall bring the omission to the Department’s attention so that a contract alteration may be processed that adds the missing steel to the table and its price adjustments to the Contract.

The Base Price Date is the month and year in which MassDOT opened bids for the project. This date is used to select the Base Price Index.

Period Prices of unfabricated structural steel and unfabricated reinforcing steel on a project are variable prices that have been calculated using the Period Price Date and an index of steel prices to adjust the Base Price.

The Period Price Date is the date the steel was delivered to the fabricator as evidenced by an official bill of lading submitted to the Department containing a description of the shipped materials, weights of the shipped materials and the date of shipment. This date is used to select the Period Price Index.

The index used for the calculation of Period Prices is the U.S. Department of Labor Bureau of Labor Statistics Producer Price Index (PPI) Series ID WPU101702 (Not Seasonally Adjusted, Group: Metals and Metal Products, Item: Semi-finished Steel Mill Products.) As this index is subject to revision for a period of up to four (4) months after its original publication, no price adjustments will be made until the index for the period is finalized, i.e., the index is no longer suffixed with a “(P)”.

Period Prices are determined as follows:

Period Price = Base Price X Index Factor

Index Factor = Period Price Index / Base Price Index

Example of a Period Price Calculation:

Calculate the Period Price for December 2009 using a Base Price from March 2009 of \$0.82/Pound for 1,000 Pounds of ASTM A709 (AASHTO M270) Grade A36 Structural Steel Plate.

The Period Price Date is December 2009. From the PPI website*, the Period Price Index = 218.0.

The Base Price Date is March 2009. From the PPI website*, the Base Price Index = 229.4.

Index Factor = Period Price Index / Base Price Index = 218.0 / 229.4 = 0.950

Period Price = Base Price X Index Factor = \$0.82/Pound X 0.950 = \$0.78/Pound

Since \$0.82 - \$0.78 = \$0.04 is less than 5% of \$0.82, no price adjustment is required.

If the \$0.04 difference shown above was greater than 5% of the Base Price, then the price adjustment would be 1,000 Pounds X \$0.04/Pound = \$40.00. Since the Period Price of \$0.78/Pound is less than the Base Price of \$0.82/Pound, indicating a drop in the price of steel between the bid and the delivery of material, a credit of \$40.00 would be owed to MassDOT. When the Period Price is higher than the Base Price, the price adjustment is owed to the Contractor.

* To access the PPI website and obtain a Base Price Index or a Period Price Index, go to

<http://data.bls.gov/cgi-bin/srgate>

End of example.

The Contractor will be paid for unfabricated structural steel and unfabricated reinforcing steel under the respective contract pay items for all components constructed of either structural steel or reinforced Portland cement concrete under their respective Contract Pay Items.

Price adjustments, as herein provided for, will be paid separately as follows:

Structural Steel

Pay Item Number 999.449 for positive (+) pay adjustments (payments to the Contractor)

Pay Item Number 999.457 for negative (-) pay adjustments (credits to MassDOT Highway Division)

Reinforcing Steel

Pay Item Number 999.466 for positive (+) pay adjustments (payments to the Contractor)

Pay Item Number 999.467 for negative (-) pay adjustments (credits to MassDOT Highway Division)

No price adjustment will be made for price changes after the Contract Completion Date, unless the MassDOT Highway Division has approved an extension of Contract Time for the Contract.

BASE PRICES

The Department's table of Base Prices specified above is updated monthly. The current table is attached to this Document 00813 and included in each new contract.

DOCUMENT 00814

SPECIAL PROVISIONS
PRICE ADJUSTMENT FOR PORTLAND CEMENT CONCRETE MIXES

January 12, 2009

This provision applies to all projects using greater than 100 Cubic Yards (76 Cubic Meters) of Portland cement concrete containing Portland cement as stipulated in the Notice to Contractors section of the Bid Documents. This Price Adjustment will occur on a monthly basis.

The Price Adjustment will be based on the variance in price for the Portland cement component only from the Base Price to the Period Price. It shall not include transportation or other charges.

The Base Price of Portland cement on a project is a fixed price determined at the time of bid by the Department by using the same method as for the determination of the Period Price (see below) and found in the Notice to Contractors.

The Period Price of Portland cement will be determined by using the latest published price, in dollars per ton (U.S.), for Portland cement (Type I) quoted for Boston, U.S.A. in the **Construction Economics** section of *ENR Engineering News-Record* magazine or at the ENR website <http://www.enr.com> under **Construction Economics**. The Period Price will be posted on the MassHighway website the Wednesday immediately following the publishing of the monthly price in ENR, which is normally the first week of the month.

The Contract Price of the Portland cement concrete mix will be paid under the respective item in the Contract. The price adjustment, as herein provided, upwards or downwards, will be made after the work has been performed, using the monthly period price for the month during which the work was performed.

The price adjustment applies only to the actual Portland cement content in the mix placed on the job in accordance with the Standard Specifications for Highways and Bridges, Division III, Section M4.02.01. No adjustments will be made for any cement replacement materials such as fly ash or ground granulated blast furnace slag.

The Price Adjustment will be a separate payment item. It will be determined by multiplying the number of cubic yards of Portland cement concrete placed during each monthly period times the Portland cement content percentage times the variance in price between the Base Price and Period Price of Portland cement.

This Price Adjustment will be paid only if the variance from the Base Price is 5% or more for a monthly period. The complete adjustment will be paid in all cases with no deduction of the 5% from either upward or downward adjustments.

No Price Adjustment will be allowed beyond the Completion Date of this Contract, unless there is a Department-approved extension of time.

*

END OF DOCUMENT

SECTION 00815BASE PRICESPART 1 - GENERAL1.1 DESCRIPTION

- A. In accordance with Massachusetts General Law (MGL) Chapter 30, Section 38A, contracts for water and sewer projects awarded under MGL Chapter 30 Section 39M shall include price adjustment clauses for fuel (both diesel and gasoline), liquid asphalt and Portland cement contained in cast-in-place concrete.
- B. The work under this Contract includes price adjustments for hot mix asphalt, Portland cement, diesel fuel, and gasoline. Base Prices for hot mix asphalt, Portland cement, diesel fuel, and gasoline under this Project are defined as the Price presented on the Massachusetts Department of Transportation (MassDOT) website. MassDOT posts Price Adjustments on their Highway Division's website at <http://www.massdot.state.ma.us/Highway/> under the following link sequences:

Website: massdot.state.ma.us

Tab1: Highway

Link1: Doing Business with Us

Link2: Construction

Link3: Price Adjustments

Prices may not be available for the month in which the project is Bid at the time the project is advertised for Bid. The Base Price will be confirmed after Contract Award and before the first monthly payment requisition. For this project, the recent Base Price History for the specified items is presented within Table 1.

Table 1. Base Prices for the Contract

Adjustment Period	Diesel	Gasoline	Liquid Asphalt	Portland Cement
	Gallon	Gallon	Ton	Ton
January 2019	\$ 1.559	\$ 1.593	\$ 500.00	\$ 136.39

*Published prices as of October 14, 2020.

END OF SECTION

SECTION 00821

PERMITS

PART 1 GENERAL

1.01 CONTRACT DOCUMENTS

- A. The general provisions of the Contract, including General and Supplemental Conditions and General Requirements, apply to the work specified in this section.

1.02 PERMITS

- A. The Contractor shall be responsible for obtaining and complying with all permits required of his equipment, work force, or particular operations (such as blasting and fuel storage permits, etc.) in the performance of the Contract. All costs associated with obtaining permits will be included in the price of the work.
- B. If included as part of this project, The Contractor shall be responsible for complying with requirements of the Local Conservation Commission and the Cambridge Watershed Protection District. All costs associated with complying with the conditions will be included in the price of the work.
- C. The Contractor shall be responsible for obtaining and complying with the requirements of the Street Opening and Trench Permits required by the City Department of Public Works in the performance of the Contract. All costs associated with complying with the conditions of the permits will be included in the price of the work. All costs associated with obtaining permits will be waived by the City.

END OF SECTION

ATTACHMENT A

SPECIAL PROVISIONS

KENMORE TERRACE SEWER MAIN REPLACEMENT

CITY OF WALTHAM CONSOLIDATED PUBLIC WORKS DEPARTMENT

SCOPE OF WORK

The work to be done under this Contract consists of the installation of approx. 130 feet 8" sewer main on Kenmore Terrace in Waltham.

The work to be performed will include excavation, removal of the existing sewer main, installation of the new sewer main, replacing existing sewer and water services, backfill, and related appurtenances, hot mix asphalt patching of streets and sidewalks, resetting of curb, pavement milling and paving with hot mix asphalt, and other incidental work as required.

Work under this Contract shall be paid for at the Contract unit bid prices, which shall constitute full compensation for all material, labor, equipment, etc., required to satisfactorily complete the work.

All work under this Contract shall be done in conformance with the Massachusetts Highway Department *Standard Specifications for Highways and Bridges* dated 1988, the *Supplemental Specifications* dated July 1, 2015, and the *Interim Supplemental Specifications*; the *2015 Construction Standard Details*, the *1990 Standard Drawings for Signs and Supports*; the *2009 Manual on Uniform Traffic Control Devices (MUTCD)* with *Massachusetts Amendments* and the *Standard Municipal Traffic Code*; the *1968 Standard Drawings for Traffic Signals and Highway Lighting*; the latest edition of *American Standard for Nursery Stock*; the latest edition of the American Water Works Association Standards, the Plans and these Special Provisions

WORK SCHEDULE

Work on this project is restricted by City Ordinance to a ten (10) hour day between the hours of 7:00am and 5:00pm. Work week is restricted to a five (5) day week Monday through Friday, with the Contractor and all subcontractors working on the same shift. No work shall be done on this Contract on Saturday's, Sunday's, or holidays without the prior written approval by the City. Weekly work schedules shall be delivered to the Engineer no later than noon on the Friday before the following work week.

No work shall be performed on the entire length of any street or roadway listed below during the hours of 7:00am to 9:00am and 4:00pm to 6:00pm. Also no construction vehicles shall be parked waiting to perform work during these hours. In case of emergency, exceptions to this rule can be made by the Consolidated Public Works Director or their designee. Any non-emergency work would be reviewed on a case-by-case basis and approval may be issued by the Consolidated Public Works Director or his/her designee. Street or roadways restricted are as follows: Bacon St., Bear Hill Rd., Beaver St., High St., Lexington St., Linden St., Main St., Maple St., Moody St., Newton St., Pine St., Prospect St., River St., Second Ave., Smith St., South St., Stow St., Totten

Pond Rd., Trapelo Rd., Waverley Oaks Rd., Weston St., Winter St., and Wyman St.

CHANGES IN SCOPE

The City of Waltham reserves the right to increase or reduce the amount of this Contract. Any changes in scope may involve adding work on the streets listed above or on streets yet to be identified, or deleting all or some of the work on a specific street or portion of a street. Changes in scope may be ordered at any time up to project acceptance at the Contract unit bid prices.

DEFINITIONS

Except for specific reference to Department Standards and Operations, the usage of the term Engineer shall mean the Waltham City Engineer or his/her duly authorized Agent.

RESPONSIBILITY FOR DAMAGE CLAIMS

The Contractor shall indemnify, defend and save harmless the Municipality and all of its or their offices, agents and employees against all suits, claims or liability of every name and nature, for or on account of any injuries to persons or damage to property arising out of or in consequence of the acts of the Contractor in the performance of the work covered by the Contract or failure to comply with the terms and conditions of said Contract, whether by themselves or his/her employees or Subcontractors, but only in respect of such injuries or damages sustained during the performance and prior to the completion and acceptance of the work covered by the Contract.

The Contractor will be held responsible for any and all claims for damage to underground structures such as, but not restricted to, water or gas mains, pipes, conduits, manholes or catch basins, due to his/her operation or to the operations of any of his/her Subcontractors.

COOPERATION BY CONTRACTOR

Attention is directed to the provisions relating to rights of public corporations and municipal departments to enter the site of the improvement and alter, replace, and/or install facilities at such times when the Contractor will be prosecuting other required work contiguous thereto.

INSPECTION OF WORK

The Contractor is advised that the Waltham City Engineer will be provided with a schedule of operations and will at various times during the construction of the project be on-site to inspect procedures and give directions. For the purpose of observing work that affects their respective properties, inspectors for public agencies and utility companies shall be permitted access to the work, but all official orders and directives to the Contractor will be issued by the Waltham City Engineer or his/her duly authorized agent.

NOTICE TO OWNERS OF UTILITIES AND PUBLIC SERVICE DEPARTMENTS:

Written notice shall be given by the Contractor to all public service corporations or officials owning or having charge of Public or Private Utilities and Departments of his/her intentions to commence operations affecting such utilities and Departments at least one (1) week in advance of the start of such operations and the Contractor shall at the same time file a copy of said notice with the Engineer.

The names of the principal City Departments and Utilities which may be affected will be provided to the Contractor at the pre-construction meeting.

The Contractor shall notify “Massachusetts DIG SAFE” and procure a DIG SAFE number 72 hours prior to disturbing existing ground in any way. DIG SAFE Call Center – PHONE - 811.

The City of Waltham is not a part of “DIG SAFE.” The Contractor must request Water, Sewer, and Drain utility markings from the City Water & Sewer Department at least 72 hours prior to disturbing existing ground in any way.

Before the Contractor begins any work on operations which might result in damage to utility pipes or structures the Contractor shall verify the locations of existing overhead and subsurface utilities in the vicinity of the work with the listed Departments and Utility Companies and conduct his/her operations so as to avoid any damage to them.

PROTECTION OF EXISTING UTILITIES AND STRUCTURES

Excavation and backfill operations shall be carried out in a manner that will prevent cave-in of excavations or the undermining, damage or disturbing of existing utilities and structures or of new work.

Any excavations improperly backfilled, or where settlement occurs, shall be reopened to the depth required, then refilled with new materials and compacted, and the surface restored to the required grade and condition at no additional expense to the Owner.

Any damage due to excavation, backfilling or settlement of the backfill, or injury to persons or damage to property occurring as a result of such damage, shall be the responsibility of the Contractor. All costs to repair such damage, in a manner satisfactory to the Owner, shall be borne by the Contractor at no additional expense to the Owner.

Where existing subsurface utilities or other facilities adjacent to or crossing through the excavation require temporary support or protection, such temporary support or protection shall be satisfactorily provided by the Contractor at no additional expense to the Owner. All necessary measures shall be taken by the Contractor to prevent lateral movement or settlement of existing facilities or of work in progress.

The plans indicate the approximate location of existing overhead and subsurface utilities in the vicinity of the work and the bidders are advised to verify this information, as its accuracy and completeness are not guaranteed by the Owner or Engineer.

PROTECTION OF UTILITIES AND PROPERTIES

The Contractor's attention is directed to the location of underground utilities in the existing and proposed roadways.

The Contract Drawings indicate the approximate location in plan of existing overhead and subsurface utilities in the vicinity of the work. Whatever measures are necessary to protect these lines during the work shall be included in the Contract unit price for the various items involved.

In case of damage to utilities, the Contractor shall promptly notify the Owner and shall, if requested, furnish manpower under the Owner's direction in getting access to the utility. Pipes or other structures damaged by the operation of the Contractor may be repaired by the Owner, the municipality, or the utility company. The cost of such repairs shall be borne by the Contractor without compensation therefore.

The work to be done under this Contract may necessitate changes in the properties of utility companies or the municipality hereinbefore listed. Immediately after executing the Contract, the Contractor shall confer with the owners of all utilities in order that relocations of mains or services may be made at times consistent with operations of the Contract.

PROVISIONS FOR TRAVEL AND PROSECUTION OF THE WORK

Prior to commencement of work, the Contractor shall be responsible for obtaining all necessary construction permits. Permits will include, but are not necessarily limited to, a Street Opening / Trench Permit from the Consolidated Public Works.

Access shall be maintained for all abutters so that they may use the driveways and approaches adjacent to their properties. Pedestrian access to abutting property and access for emergency vehicles shall be provided at all times.

All construction equipment, material and debris shall be removed from the traveled way at the end of each working day and shall be stored in such manner as not to interfere with the flow of driveway traffic or pedestrians.

The Contractor shall coordinate his/her work with the work to be done by other Contractors on the site, public utilities or other agencies, and he/she shall so schedule his/her operations as to cause the least interruption to the normal flow of all traffic types. Reasonable facilities shall be provided by the Contractor for the safe and convenient passage of pedestrians and vehicles through and within the project area.

Particular care shall be taken to establish and maintain methods and procedures which will not create unnecessary or unusual hazards to public safety. The placement of necessary devices will be for daily work periods and shall be removed after the completion of work operations. Signs having messages that are irrelevant to normal traffic conditions shall be removed or properly covered at the end of each work period. Signs are to be kept clean at all times and legends shall be distinctive and unmarred.

TRAFFIC MANAGEMENT PLAN

The Contractor shall prepare and submit a traffic management plan to the Engineer for review and approval by the Engineer and the Waltham Police Department Traffic Safety Officer. The Traffic Management Plan shall be prepared for all streets in the Contract, unless specifically directed otherwise by the Engineer. The Traffic Management Plan shall contain information on proposed detour routes if requested, location and type of detour and warning signs, barricades and other safety and traffic control means and devices to ensure a safe, orderly flow of vehicular and pedestrian traffic.

All temporary and permanent signs, traffic control devices, and pavement markings shall conform to the latest relevant sections of the Manual on Uniform Traffic Control Devices (MUTCD), and the Massachusetts Standard Specifications for Highways and Bridges.

The Traffic Management plan shall be submitted for review at least fourteen (14) days prior to any work being performed on the project roadways. No work would be allowed until the Traffic Management Plan is approved by the City and implemented by the Contractor.

Temporary pavement markings and other traffic control devices shall be provided in accordance with the Contractor's Traffic Management Plan and as directed by the Engineer.

Temporary traffic control devices shall include the provision of variable message sign boards to supplement other traffic control measures as directed by the Engineer. The cost of preparing the traffic management plan and providing and maintaining temporary traffic control devices shall be borne by the Contractor.

RAILROAD FLAGGING SERVICE

If any of the work required to be done by the Contractor may obstruct the tracks of a railroad or in any way endanger the operation of its trains, and the services of a flagger or flaggers or other railroad employees are required by the Chief Engineer of the railroad company and personnel are assigned by that Chief Engineer for the protection of the property and traffic of the Railroad against hazards, the cost of all such flagging services will be paid by the Contractor to their employers, subject to the rules and regulations of the railroad company. The Contractor shall provide to the City proof of payment to the Railroad for the cost of the flaggers required. The City shall reimburse the Contractor for the flaggers under item 999.2 Railroad Flagging. The City shall not pay any administrative charges associated with the costs of flaggers charged by the railroad nor shall the Department pay charges for debit accounts if such accounts are required by the railroad.

METHOD OR SEQUENCE OF CONSTRUCTION

The Contractor shall obtain approval for his/her proposed method and sequence of construction, including procedures for maintaining traffic, from the City Engineer or his/her duly authorized agent, prior to performing the work. The Contractor is responsible for filling out and submitting to the Engineer the one page checklist included at the end of

this section prior to commencing a new segment or phase of work. The checklist describes the type of work to be done and identifies a series of notifications and preliminary steps that are to be addressed prior to commencing a new segment or phase of work.

OSHA REQUIREMENTS

The work to be performed under this Contract by the General Contractor and any and all subcontractors is to be performed in compliance with the Occupational Safety and Health Act of 1970, including any and all amendments thereto.

PRECAUTIONS UNDER ELECTRIC LINES

The bidders attention is directed to the AASHTO Guide on Occupational Safety on Highway Construction Projects, Subpart N, 1926.550, relating to construction equipment clearances at overhead electric lines, which states in part "... the minimum clearance between the lines and any part of the crane or load must be at least 10 feet from lines rated 50 KV or below, and greater distances for high voltage ...".

For the protection of personnel and equipment, the Contractor should be aware of this regulation especially during paving operations using large semi-trailer vehicles.

OVERLOADED TRUCKS

Materials delivered to the project in motor vehicles or semi-trailer units that exceed the legal maximum gross weight allowed for the particular class as specified in section 19a of chapter 90 of the general laws of Massachusetts will not be accepted.

PUBLIC SAFETY AND CONVENIENCE

Trenches shall not be excavated in traveled ways until all materials and equipment required for such work are at the site and available for immediate use. When work is not in progress, trenches in areas subject to public travel shall be covered with steel plates capable of safely sustaining a 36.5-ton truckload with impact without additional compensation. The work in each trench shall be practically continuous, with the placing of pipe, backfilling, and paving of the roadway surfaces closely following each preceding operation. Payment for steel plates will be included under the unit bid price per linear foot for the respective pipe or conduit item, regardless of width of trench.

The Contractor shall take every measure necessary for the protection of personnel and property.

The Contractor shall at all times, until written acceptance of the physical work by the Owner, be responsible for the protection of the work and shall take all precautions for preventing injuries to persons or damage to property on or about the project.

BARRICADES AND WARNING SIGNS

All automotive equipment not protected by traffic cones or flares that is working on the project in areas open to traffic shall have one amber flashing or strobe warning light

mounted on the cab roof or on the highest practical point of the machinery. These lights shall be in operation whenever the equipment is working or traveling in the project work area at a speed less than 25 M.P.H. Flashers must be visible to both oncoming and overtaking vehicular traffic and shall have a light source of 32 minimum candlepower and a flashing frequency of 50-60 times per minute.

All personnel who are working in areas open to traffic shall wear MHD approved safety vests.

All vehicles except passenger cars which are assigned to the project which operate at speeds of 25 MPH or less shall have an official SLOW MOVING VEHICLE emblem displayed in accordance with the provisions of Section 7 of Chapter 90 of the General Laws as amended by Chapter 684 of the Acts of 1970.

STEEL PLATES IN CONSTRUCTION ZONES

At the end of each working day where trenches in areas of public travel are covered with steel plates, each edge of such plates shall be either beveled or protected by a slope of 2-feet horizontally to 1-inch vertically. Temporary bituminous concrete patching material shall be used to construct the ramps. The cost of necessary patching materials and their maintenance and removal will be considered incidental to the item involved with no separate payment.

DISPOSAL OF SURPLUS EXCAVATED MATERIALS

All surplus excavated material not required or suitable for reuse on the project, or otherwise not wanted by the City, shall become the property of the Contractor and removed and disposed of outside and away from the limits of the project at no additional cost to the City in accordance with all local rules and the approval of local governmental authorities having jurisdiction over the disposal of such materials. Any excess material that the City decides to keep shall be transported to and stored at a location within City to be identified by the Engineer. Loading, transporting, and unloading shall be done by the Contractor without additional compensation.

Payment for this work shall be included in the unit price under the applicable item from which the material was obtained.

PROMPT PAYMENT AND RELEASE OF RETAINAGE TO SUBCONTRACTORS

The Contractor agrees to pay each subcontractor under this Contract for satisfactory performance of subcontract work not later than 10 business days from the receipt of each payment the Contractor receives from the City. Failure to comply with this requirement may result in the withholding of payment to the Contractor until such time as all payment due under this provision has been received by the subcontractor(s) and/or referral to the Prequalification Committee for action which may affect the Contractor's prequalification status.

ARCHITECTURAL ACCESS BOARD TOLERANCES

The Contractor is hereby notified that they are ultimately responsible for constructing all project elements in strict compliance with the current AAB/ADA/PROWAG rules,

regulations, standards and guidelines (Rules and Regulations).

All construction elements in this project associated with sidewalks, walkways, wheelchair ramps and curb cuts are controlled by 521CMR - Rules and Regulations of the Architectural Access Board (AAB) and the Accessibility Guidelines for Pedestrian Facilities in the Public Right of Way (PROWAG)

The Rules and Regulations specify maximum slopes and minimum dimensions required for construction acceptance. There is no tolerance allowed for slopes greater than the maximum slope nor for dimensions less than the minimum dimensions.

Contractors shall establish grade elevations at all wheel chair ramp locations, and shall set transition lengths according to the appropriate table in the Construction Standards (or to the details shown on the plans).

All wheelchair ramp joints and transition sections which define grade changes shall be formed, staked and checked prior to placing cement concrete. All grade changes are to be made at joints.

DEBRIS IN DRAINAGE AND SEWER STRUCTURES

The Contractor shall exercise care when conducting his/her operations so that the debris does not enter any structures. All structures and pipes shall be kept clean and operable. All costs of debris removals, damages due to back-ups, and cleaning by others due to operations of the Contractor shall be borne by the Contractor.

PROCEDURES FOR SHOP DRAWING SUBMITTALS

The following procedure shall be followed when making shop drawing submittals for this project:

1. The Contractor shall submit four (4) sets of drawings directly to the Engineer for preliminary review.
2. The Engineer will send a written reply, returning two (2) sets to the Contractor within seven (7) working days of receipt of the drawings.
3. If the Engineer's reply indicates rejection or advises corrections or additions to the drawings, steps 1 and 2 are repeated until the Engineer indicates that approval will be given.
4. The Contractor shall then submit four (4) sets of drawings to the Engineer for approval and distribution by the Engineer per the standard operating procedures of the Department.
5. The Contractor shall take care that every separate document in each set of every submittal shall carry the following identifying information:

Information Required

- a. Project No.
- b. Identifying Item Number from proposal, if applicable
- c. Locations where material is proposed to be used, if applicable
- d. Name of submitting Contractor
- e. Personal signature and title of an official of the Contractor authorized to make shop drawings submittals

f. Date of signature or submittal

The Contractor shall not receive payment for nor will he/she be allowed to install any item or materials which require shop drawing approval unless and until he/she receives shop drawing approval for that item.

Within 15 days after receipt of an approved shop drawing for any item, the Contractor shall provide the Engineer written proof that he/she has ordered such approved materials required on the subject Contract and a written confirmation on such order and delivery schedule from the manufacturer of the item. This delivery schedule shall be appropriate for timely completion of this project.

SAWCUTS

Sawcuts shall be made in existing pavements to provide a neat, square edge at limits of excavation and to provide a clean joint where new pavement and sidewalks are to match existing. Sawcuts shall also be made where shown on the Contract Drawings, or otherwise directed by the Engineer. Sawcuts shall be made to the depth directed and shall be clean and even. All cuts shall be made using an approved power driven saw. All sawcuts shall be considered incidental and compensation will be included in the Contract bid prices for the related work items.

CONCRETE COLLARS

Concrete collars, as per the standard construction details, shall be placed around drainage and sewer and telephone structures, water service boxes, and utility boxes that are located in pavement areas as directed by the Engineer. High early strength concrete shall be used if required by the Engineer. Concrete used for collars shall not be measured for payment. Compensation shall be included in the Contract bid price for the respective items.

ASPHALT JOINTS

Tack coat and sand shall be applied to all joints composed of hot mix asphalt immediately after paving, or as required by the Engineer. Tack coat and sand, when applied to joints as described, shall be considered incidental and compensation shall be included in the Contract bid price for the respective hot mix asphalt items.

DEWATERING

Where excavations become inundated with water, whether from groundwater or surface runoff, the Contractor shall be responsible for dewatering the excavation prior to installing structures and/or pipes and backfill. Dewatering activities shall be performed in accordance with the details shown on the plans. Locations of materials and methods used for dewatering shall be approved by the Engineer prior to use. Costs associated with dewatering activities shall be considered incidental to the overall project, and no additional compensation shall be made.

PROTECTION OF EXISTING TREES

Trees and shrubs that are not designated on the plans, or by the Engineer, to be cut, removed, destroyed or trimmed shall be saved from harm and injury. The Contractor shall provide measures to prevent any harm and injury caused during construction operations.

DISTURBANCE OF EXISTING BOUNDS

Where existing bounds are disturbed by the Contractor's activities, they shall be reset by a Registered Land Surveyor at the Contractor's expense. Where the existing bounds conflict with the proposed construction, removal and resetting of the bounds shall be paid for under Item 711 - Bound Removed and Reset.

A certification by the Registered Land Surveyor performing the work shall be made and submitted to the Engineer for all bounds reset.

MATERIALS TESTING

All materials used in the construction of the project shall be subject to inspection, examination, or testing, by a certified materials testing laboratory as determined necessary by the Engineer.

RECORD DRAWINGS (AS-BUILT) DOCUMENTS

At the conclusion of construction and prior to final payment the Contractor shall submit ties to all curb stops, bends, valves and other water appurtenances installed as well as invert elevations for all drainage or sewer structures installed or altered as part of the Work under this Contract. Copies of legible and detailed field notes or marked up design plans shall be provided to the Engineer.

ITEM 120.1**UNCLASSIFIED EXCAVATION****CUBIC YARD**

The work to be done hereunder consists of removing and disposing of materials in accordance with the relevant provisions of Section 120 as amended and supplemented by the following: all materials obstructing the execution of other required work as shown on the plans and/or as directed except those materials for which payment is made as part of other items of this Contract.

The Contractor's attention is directed to the fact that materials shall be disposed of in accordance with the provisions written hereinbefore under the heading "Disposal of Surplus Excavated Materials".

Materials encountered in the excavation may include but are not necessarily limited to, earth, bituminous or cement concrete pavements and curb, Class A Rock, ledge, masonry, pipe, timber, cobblestones, stone pavers, cinders, trees and stumps, and other materials from previous constructions.

Where, in the opinion of the Engineer, the present roadway foundation is of suitable material, it shall only be excavated to a depth determined by the Engineer. Should unsatisfactory subgrade material be encountered, the Engineer may direct that excavation be carried to satisfactory material and the area be backfilled with gravel borrow, or other material, as directed by the Engineer. Payment for gravel borrow, if used, will be made under Item 151, Gravel Borrow.

Any work done or materials used for backfilling in excess of the depth authorized shall be at the Contractor's expense and will not be paid for under the Contract items involved.

The accepted quantity of Unclassified Excavation will be paid for at the Contract unit price per cubic yard under Item 120.1, Unclassified Excavation.

ITEM 129.**PAVEMENT MILLING****SQUARE YARD**

This work to be performed under this Item shall conform to the relevant provisions of Section 120, supplemented by the following:

The adjusting of all drainage, utility, and municipality structures, gate boxes, and service boxes within the limits of areas to be cold planed and overlaid shall be done at the direction of the engineer. Payment for the adjustment of castings work is to be made at the unit bid price for the respective items.

Excavated material resulting from the milling operation shall be disposed of by the Contractor in accordance with the requirements of "DISPOSAL OF SURPLUS EXCAVATED MATERIALS", payment for which is to be included in the unit bid price for Item 129.

The accepted quantity of Pavement Milling will be paid for at the Contract unit price per

square yard under Item 129.

ITEM 141.1.

TEST FOR EXPLORATION

CUBIC YARD

Excavate test pits, as shown on the plan or at the direction of the Engineer, to locate underground utilities or structures in advance of the construction. Backfill test pits immediately after their purpose has been satisfied and restore and maintain the surface in a manner satisfactory to the Engineer.

Payment for test pits will be based on the material removed which will be paid for at the Contract unit price per cubic yard. No additional compensation shall be made for the test pits not directed by the Engineer, or shown on the plan but is carried out at the discretion of the Contractor to benefit the installation.

The work to be performed under this Item shall conform to the relevant provisions of Section 140, amended or supplemented as follows:

The work to be performed under this Item consists of all work required to excavate test pits, as required, and as approved by the Engineer, to locate structures and utilities within the proposed work area. Also included is work required to backfill test pits with excavated material and compacting.

Work required to place and compact backfill to replace unsuitable material in test pits shall be paid for under Item 151, Gravel Borrow. Gravel borrow for pavement subbase will be paid under the same item.

Test pit for exploration shall be measured in accordance with Section 140 of the Standard Specifications.

Payment for test pit for excavation shall be at the contract unit price per cubic yard, which shall be full compensation for all labor, material, tools and equipment necessary or incidental to complete the work including patching the test pit with Hot Mix Asphalt.

ITEM 144.

CLASS B ROCK EXCAVATION

CUBIC YARD

The work to be performed under this Item shall conform to the relevant provisions of Section 140 and the following:

The Contractor's attention is directed to the fact that materials shall be disposed of in accordance with the provisions written hereinbefore under the heading "Disposal of Surplus Excavated Materials".

Where, encountered in the construction of water, sewer and drain pipes and structures the removal and satisfactory disposal of all ledge and boulders greater than 1 cubic yard shall be measured and paid for under item 144. The removal shall be by blasting or power tools such as a hoe ram or jack hammer. Removal operations shall be so prosecuted that no damage will be caused to the adjacent structures.

U.S. Department of Labor, Occupational Safety and Health Administration, (OSHA) including but not limited to:

29 CFR 1910 Section 1001 and 29 CFR 1926 Section 58 Occupational exposure to Asbestos, Tremolite, Anthophyllite and Actinolite, Final Rule
29 CFR 1910 Section 134 Respiration Protection
29 CFR 1926 Construction Industry
29 CFR 1910 Section 2 Access to Employee Exposure and Medical Records
29 CFR 1910 Section 1200 Hazard Communication
29 CFR 1910 Section 145 Specifications for Accident Prevention Signs and Tags

U.S. Environmental Protection Agency, (EPA) including but not limited to:

40 CFR 762, CPTS 62044, FRL 2843-9, Federal Register Vol. 50 no.134, July 12, 1985 p.28530 - 28540 Asbestos Abatement Projects Rule
40 CFR 61 Subpart A Regulation for Asbestos
40 CFR 61 Subpart M (Revised Subpart B) National Emission Standard for Asbestos
U.S. Department of Transportation 49 CFR 172 and 173

Massachusetts Department of Labor and Industries Regulations, (DLI) including but not limited to:

453 CMR 6.00 Removal, Containment and Encapsulation of Asbestos

Massachusetts Department of Environmental Protection (DEP) including but not limited to (supplementing subsection 7.01):

310 CMR 7.00, Section 7.09 Odor and Dust, Section 7.10 Noise, Section 7.15 Air Pollution Control Regulations Massachusetts Department Of Transportation Highway Division Project No. 605353.

310 CMR 18.00 and 19.00 Solid Waste Regulations

Massachusetts Division of Industrial Safety 45 CMR 10.00

Local Requirements including but not limited to those of Health Departments and Fire Departments.

Wherever there is a conflict or overlap of the above references, the most stringent provision shall apply.

All asbestos material shall be removed and properly disposed of by a Contractor or subcontractor with a current Massachusetts Abatement Contractors License issued by the Department of Labor and Industries. Work shall be supervised by a competent person as required by OSHA in 29 CFR 1926 to ensure regulatory compliance. This person must have completed a course at an EPA Training Center or equivalent course in asbestos abatement procedures, have had a minimum of four years on-the-job training and meet

any additional requirements set forth in 29 CFR 1926 for a Competent Person. This person must also be certified by the Commonwealth as an Asbestos Abatement Supervisor and Asbestos Abatement Project Designer as required by 453 CMR 6.00.

Asbestos removal work shall be coordinated with all other work under the Contract and shall be completed prior to performing any activities which could disturb the asbestos material or produce airborne asbestos fibers.

Dust suppression in the form of light water sprays, foams, dust suppressants and calcium chloride will be implemented as required to control dusting during trenching and excavation. Alternatively, intrusive activities may be reduced or curtailed under high wind or heavy rain conditions, which in the opinion of the HASP may pose a safety hazard to the workers.

NOTIFICATION AND PERMITS

The Contractor shall prepare a formal pre-notification form at least ten (10) days prior to the start of asbestos removal work. This form must be submitted to the appropriate Regional Office of the Massachusetts Department of Environmental Protection and to the U.S. Environmental Protection Agency Region I Air and Hazardous Material Division. A copy of the submitted forms must be provided to the Engineer and kept at the work site.

The Contractor shall also obtain and pay all other applicable asbestos waste transportation and disposal permits, licenses and fees.

STANDARD OPERATING PROCEDURES

The standard operating procedure shall ensure the following:

1. Proper site security including posting of warning signs and restricting access to prevent unauthorized entry into the work spaces.
2. Proper protective clothing and respiratory protection prior to entering the work spaces.
3. Safe work practices including provisions for communications; exclusion of eating, drinking, smoking, or use of procedures or equipment that would in any way reduce the effectiveness of respiratory protection or other engineering controls.
4. Proper exit practices from the work space through the showering and decontamination facilities.
5. Removing asbestos containing material in ways that minimize release of fibers.
6. Packing, labeling, loading, transporting and disposing of contaminated material in a way that minimizes or prevents exposure and contamination.
7. Emergency evacuation of personnel, for medical or safety (fire and smoke) so that exposure will be minimized.
8. Safety from accidents in the work space, especially from electrical shocks, slippery surfaces and entanglements in loose hoses and equipment.
9. Provisions for effective supervision and OSHA - specified personnel air monitoring for exposure during work.

REQUIRED SUBMITTALS

The Contractor shall submit to the Engineer the following listed items at least ten (10) calendar days prior to the start of asbestos work. No asbestos removal work activities shall commence until these items are reviewed by the Engineer, unless otherwise waived. Submittals shall be clearly labeled and in sufficient detail to enable the Engineer to form an opinion as to its conformity to the specifications.

1. Name, experience and DLI certification of proposed Supervisors and Foreman responsible for asbestos work.
2. Summary of workforce by disciplines and a notarized statement documenting that all proposed workers, by name, have received all required medical exams and have been properly trained and certified for asbestos removal work, respirator use and appropriate Massachusetts DLI, EPA and OSHA standards. Massachusetts
3. Notarized statement that workers are physically fit and able to wear and use the type of respiratory protection proposed for the project. Notarized certification signed by an officer of the abatement contracting firm that exposure measurements, medical surveillance and worker training records are being kept in conformance with 29 CFR 1926.
4. Written plan of action and standard operating procedures to include: location and layout of decontamination areas; sequencing of asbestos work; detailed schedule of work activities by date and interface with other project activities which affect work performance; methods used to assure safety and security; worker protection and exposure monitoring; contingency and emergency evacuation procedures; detailed description of methods to be employed to control pollution; waste handling procedures.
5. Written respiratory protection program specifying level of protection intended for each operation required by the project and details of daily inspection and maintenance elements.
6. Copies of the U.S. EPA, State and local asbestos removal pre-notification forms. If applicable, lists and copies of all permits, licenses, or manifests which will be applied for and used.
7. Name, location and applicable approval certificates for primary and secondary landfill for disposal of asbestos-containing or asbestos contaminated waste. Name, address and licenses number(s) of hauler permitted to transport waste. (Submit copies of completed manifests upon disposal).

The Contractor must provide copies of daily inspection and record logs upon request of the Engineer, at any time during project. This information will include but is not limited to work area entry data, respirator inspections and maintenance, HEPA-exhaust inspections and maintenance and other work applicable activities or reports of accidents or unusual events.

Asbestos Cement Pipe removal shall be measured in linear feet. Payment for Asbestos Cement Pipe removal will be paid for at the Contract unit price per linear feet. No additional compensation shall be made for material removed beyond the limits excavation as shown in the plans or as determined by the Engineer.

<u>ITEM 220</u>	<u>DRAINAGE STRUCTURE ADJUSTED</u>	<u>EACH</u>
<u>ITEM 220.2</u>	<u>DRAINAGE STURCTURE REBUILT</u>	<u>VLF</u>
<u>ITEM 220.7</u>	<u>SANITARY STRUCTURE ADJUSTED</u>	<u>EACH</u>

The work to be performed under this Item shall conform to the relevant provisions of Section 220, supplemented by the following:

Structures to be adjusted shall be identified by the Contractor and approved by the Engineer prior to commencing with the work. Castings that are damaged due to the actions of the Contractor shall be replaced with new castings at his own expense. Structures that are adjusted will be paid for at the unit price per each, regardless of the number of times that structure is to be adjusted to a temporary or final grade. Payment for structures to be adjusted shall include modifications to the structure in line and/or grade of up to 3 feet. Adjustment of double inlet catch basins shall be counted as one unit.

If the Engineer determines that any castings require replacement, the Contractor shall install new castings as required under Items 221.1. If new castings are to be installed, payment for adjustment of the new castings shall be included under the item for the new casting.

Existing frames and grates or covers identified to be replaced shall be transported to the Public Works maintenance yard located at 169 Lexington St and stockpiled in a location identified by the engineer at no additional cost. Any frames and grates or covers determined by the Engineer to be of no further value to the City shall become the property of the Contractor and be disposed of off the project site by the Contractor without additional compensation.

Limits of drainage structures to be rebuilt shall be pre-approved by the Engineer. When in the judgment of the Engineer the masonry shows deterioration the structure shall be re-built in accordance with the provisions of Section 220.6.

Payment for the adjustment of structures shall include payment for all necessary labor, materials, and equipment required to satisfactorily complete the work, including removing and stacking existing castings to be replaced if required by the Engineer, initial setting of the new castings, adjustments to temporary grades, and adjustments to the final grade.

Drainage Structure Rebuilt will be measured by the vertical lineal foot, complete in place and will be paid for at the Contract unit price per foot, which price shall include all labor, materials, equipment and incidental costs required to complete the work including

removal of deteriorated portions of the structure, brick, block and mortar as required to rebuild the structure.

ITEM 221.1 **FRAME AND COVER - MUNICIPAL STANDARD** **EACH**

The work to be performed under these Items shall conform to the relevant provisions of Sections 201 and 220, supplemented by the following:

Frames, grates and covers shall be LeBaron Foundry, Neenah Foundry or approved equivalent. The following model numbers refer to LeBaron products:

- Frame and Cover for Drain and Sewer Manhole – LK 110A
- Frames and Grates for Catch Basins and Gutter Inlets – LF 248.

Manhole covers shall have a diamond pattern; pick holes and the appropriate word “DRAIN” or “SEWER” cast in 3-inch letters to match the corresponding utility. Where 36” frames and covers are required, they shall be provided and installed at no additional cost. Casting frames shall be set in a full mortar bed with bricks, a maximum of 8 inches thick. All castings shall be set in a full concrete collar, conforming to Standard Detail 202.9.0.

Existing frames and grates or covers identified to be replaced shall be transported to a location Waltham identified by the Engineer at no additional cost. Any frames and grates or covers determined by the Engineer to be of no further value to the City shall become the property of the Contractor and be disposed of off the project site by the Contractor without additional compensation.

Frames and grates (or covers) - municipal standard will be measured for payment per each, complete in place and will be paid for at the Contract unit price per each, which price shall include all labor, materials, equipment and incidental costs required to complete the work including initial setting of the new casting, adjustments to temporary grades, and adjustments to the final grade.

<u>ITEM 210</u>	<u>SANITARY SEWER MANHOLE</u>	<u>EACH</u>
<u>ITEM 250.04</u>	<u>4 INCH POLYVINYL CHLORIDE SANITARY SEWER PIPE</u>	<u>FOOT</u>
<u>ITEM 250.08</u>	<u>8 INCH POLYVINYL CHLORIDE SANITARY SEWER PIPE</u>	<u>FOOT</u>

The work to be done under this Item shall conform to the relevant provisions of Sections 201, 230 and the following:

The Contractor shall furnish, lay, join and test all gravity sewer pipe and appurtenant materials and equipment as indicated on the drawings and as specified herein.

1.0 MATERIALS

1.1 SANITARY SEWER MANHOLES

A. Base, Barrel, and Cone Sections: Manhole base, barrel, and cone sections shall be

precast reinforced concrete and shall conform to ASTM C478 (Precast Reinforced Concrete Manhole Sections) except as specified otherwise. Manhole base sections shall be monolithic to a point six inches above the crown of the incoming pipe. Minimum diameter for a gravity manhole shall be 48 inches. Horizontal joints between sections of precast concrete barrels shall have an elastomeric or mastic-like gasket for watertightness.

B. Inverts and Shelf: Manhole inverts and shelf shall provide a smooth sloped channel constructed to conform to the size and the shape of the inlet and discharge pipe or pipes. The invert shall be constructed of brick Grade SS meeting ASTM C32 (Sewer and Manhole Brick) and shall be constructed with mortar using Type II portland cement. The base work below the brick shall be suitable materials consisting of cast-in-place concrete, solid brick construction, or crushed stone compacted in place, subject to the approval of the Superintendent of the Water & Sewer Division.

D. Corbel of manhole (between manhole cone and frame and cover) shall be constructed of brick Grade SS meeting ASTM C32 (Sewer and Manhole Brick) and shall be constructed with mortar using Type II Portland cement. Outside of corbel shall be coated with mortar and sealed. Care shall be made to provide water tight construction. Flexible gaskets or mastic-like gasket shall be placed between the manhole frame casting and the top course of brick to provide added sealing against leaks which may be caused by thermal or frost action against the manhole cover.

1.2 SANITARY SEWER PIPE

Gravity sanitary sewer pipe and fittings shall be SDR 35 (standard dimension ratio) Polyvinyl Chloride (PVC) gravity sewer pipe conforming to current ASTM standards. Joints shall be elastomeric gasket joints, providing a watertight seal, conforming to ASTM D3212 (Joints for Drain and Sewer Plastic Pipes Using Flexible Elastomeric Seals).

1.3 CHIMNEYS

The Contractor shall provide chimneys in accordance with these specifications and as indicated on the Contract Drawings or as directed by the Engineer. The chimney pipe shall be SDR 35 PVC and match the diameter indicated on the Contract Drawings. The bottom of the chimney pipe shall be connected to the sewer main using the appropriately sized tee. The top of the chimney pipe shall be fitted with the appropriately sized wye fitting and temporary plugs. The top of the chimney pipe shall be at least five (5) feet below the finished grade. An eight foot long concrete cradle centered on the chimney shall be provided under the sewer main. The chimney pipe and fittings shall be located within an 18 inch corrugated polyethylene pipe filled with crushed stone. Payment for crushed stone and 18 inch corrugated polyethylene pipe used for chimneys shall be considered included in the associated pipe item.

The polyethylene pipe shall be provided in two sections. The bottom section shall be 24 inches in length and the top section shall vary according to design requirements. The

bottom end of the polyethylene pipe shall be cut to allow passage of the sewer main through the end of the pipe with a minimum 2 inch clearance between the edge of the cut and the sewer main. The bottom end shall be anchored in the concrete cradle under the sewer main. The top end shall be cut to allow access to the wye fitting through the sidewall of the polyethylene pipe.

2.0 EXECUTION OF WORK

2.1 SEWER BYPASS

Prior to starting any sewer work, the Contractor shall submit to the Engineer for approval a written sewer bypass plan indicating the proposed method of controlling and managing flows in the existing sewer during construction. Temporary service shut downs for individual residences shall only occur during normal working hours, with service restored at the end of each work day, and the work shall be scheduled so that temporary shut downs will not be required for more than one day per service. The Engineer may order a test of the sewer bypass to ensure functionality at no additional cost to the Contract.

2.2 LINES AND GRADES

A. Pipes shall be laid to the lines and grades shown on the drawings or as directed by the Engineer. The grade shown on the profile is that of the invert of the pipe. The work shall conform to this grade. A variation of one-eighth (1/8) inch or more from the true invert grade on gravity sewers laid on grades above one percent will be deemed sufficient reason to cause the work to be rejected. Work so rejected shall be corrected by the Contractor at his/her own expense.

B. The Contractor will establish the location of the pipe, manholes and other appurtenances, prior to construction for verification by the Engineer. The Engineer will establish bench marks along the route of the pipeline at convenient intervals for the use of the Contractor and for his/her own reference in checking the pipe and manhole inverts and other elevations throughout the project.

C. The grade and alignment of the pipe may be maintained, with the approval of the Engineer, by the use of laser beams if the Contractor can demonstrate that he/she possesses sufficient equipment and employs with sufficient experience, to utilize such method.

D. The Contractor shall furnish all labor, material, surveying equipment and tools to establish and maintain all lines and grades from basic control points furnished by the Engineer.

2.3 FOUNDATIONS

A. All pipes to be laid in open trench excavation shall be bedded and uniformly supported over their full length on foundations of the types specified and shown on the

drawings. Flat-bottomed trenches shall be excavated and dewatered prior to preparing the specified bedding. All work shall be performed in a dry trench.

B. All pipe shall be supported on a stable soil foundation. The trench shall be excavated to a depth 6" minimum below the bottom of the pipe. Crushed stone bedding shall be furnished and placed in the trench for its full width to uniformly support the pipe at the required line and grade. Suitable recesses shall be provided in the bedding to permit adequate clearance for bells, couplings, or similar projections. The bedding shall extend upward around the pipe barrel to a height of 12" above the pipe. Bedding material shall be spread in 6 inch layers, and each layer shall be compacted with twenty pound hand tampers or pneumatic tampers until the required total depth of bedding has been built up.

C. Where unstable soil conditions are encountered, the pipe shall be supported on a special foundation. The foundation shall be installed where a suitable supporting soil or rock stratum occurs at a depth greater than 6" minimum. The trench shall be excavated to the depth necessary to reach the suitable supporting stratum. The trench bottom and walls shall be covered with a geotextile fabric. Crushed stone shall then be furnished as bedding and placed in the trench for its full width. The bedding shall be spread in 6 inch layers, and each layer shall be compacted with twenty pound hand or pneumatic tampers. The bedding shall carry vertically from the supporting stratum up to an elevation 12" minimum above the top of the pipe. The special foundation shall extend for a minimum of 5'-0" beyond poor subgrade conditions.

D. Where required by the Engineer, check dams within the trench shall be constructed with an impervious soil material to prevent migration of groundwater around the sewer pipe along the backfilled trench. Check dams shall extend the width of the trench to undisturbed earth for a length of 3 feet along the pipe line, and shall extend to the top of the crushed stone bedding material, one foot above the pipe.

E. Manhole structures shall be installed on a firm bedding of 12" crushed stone. Extra depth excavation for installation of the crushed stone and the crushed stone itself shall be included in the payment for the structure being installed.

2.4 INSPECTION OF PIPE BEFORE INSTALLATION

A. All pipes and fittings shall be carefully inspected in the field before placing the trench. Cracked, broken, warped, out-of-round or otherwise defective pipe, or fittings as determined by the Contractor or Engineer, shall be pulled and not installed. Such rejected pipe shall be pulled and not installed. Such rejected pipe shall then be removed from the job site by the Contractor at his/her own expense.

2.5 INSTALLATION OF PIPE AND FITTINGS

A. After the trench has been brought to the proper grade, as hereinbefore specified, the pipe shall be laid. Unless otherwise approved by the Engineer in writing, pipe laying shall be done only in the presence of the Engineer. The Contractor shall give ample

notice of his/her schedule for pipe laying operations to the Engineer.

B. All pipe and fittings shall be carefully lowered into the trench with ropes, slings and proper equipment. Pipe cracked or otherwise damaged during or following installation shall be marked by the Contractor or Engineer and removed from the site as required.

C. Pipes shall be laid true to the grades shown on the drawings. Blocking will not be permitted except where the pipe is to be encased in concrete. Any pipe that has its grades or joints disturbed after laying shall be taken up and relaid. The interior and ends of all pipe shall be thoroughly cleaned during laying operations by means of plugs or other approved methods. Under no circumstances shall pipe be laid in water and no pipe shall be laid when trench conditions or the weather is unsuitable for such work except by permission of the Engineer.

D. Sanitary sewer cleanouts shall be installed at the property line to within 4-inches below the final grade and shall be capped with a cast iron ring and cover, fitted over the plugged PVC riser to provide protection from damage and allow future access for cleaning and inspection.

2.6 INSPECTION

A. Each section of installed sewer lines shall be visually inspected by the Engineer prior to final testing. The pipe shall be true to both line and grade, shall contain no broken pipe, shall show no leaks, shall show neither obstructions nor the projection of connecting pipes into the main pipe, and shall contain no debris or other deposits which will in any way reduce the full cross-section area of the pipe.

B. Any section of sewer pipe which does not comply with these inspection criteria, as determined by the Engineer, shall be promptly corrected, replaced or repaired by the Contractor at his/her own expense. Methods used for the correction shall be approved by the Engineer.

3.0 TESTING

A. All sewers, manholes, service connections and sewer laterals constructed under this Contract shall be tested under this section and shall satisfactorily meet the test requirements prior to final acceptance of the work. The Contractor shall be responsible for testing of the sewer for watertightness, deflection, and integrity in accordance with the following schedule.

- i. Prior to backfilling the trench, the Contractor shall test the sewer main for watertightness by performing either exfiltration or low pressure air tests for the main under the supervision and to the entire satisfaction of the Engineer. The Contractor shall also perform vacuum testing on all new manholes. The Contractor shall remove all debris from manholes and shall thoroughly flush sewers prior to testing for watertightness.

- ii. After backfilling and compacting the trench, the Contractor shall perform a mandrel test to test for deflection.
- iii. Prior to final roadway paving the Contractor shall perform a video inspection of the interior of the pipe line.

The Contractor may propose alternate testing methods, however, all testing methods will be subject to approval by the Engineer. All testing shall be witnessed and verified by the Engineer. The Contractor shall furnish all labor, testing materials and equipment (including plugs and standpipes) necessary to adequately test the sewer in accordance with these specifications.

3.1 EXFILTRATION TEST - GRAVITY SEWERS

A. The exfiltration test on each section of completed sewer shall be conducted by the Contractor in the presence of the Engineer. The Contractor shall isolate each test section, and fill the line and upstream manhole with water to a height two feet above the top of the pipe or two feet above groundwater, whichever is higher, at the highest point of the pipe section under test. The exfiltration shall be defined as the amount of water which must be added to maintain the original level. The maximum exfiltration shall not exceed 200 gallons per inch diameter per mile of main sewer per day. Exfiltration measurements shall be taken not less than one hour after all test water has been placed in any sewer section and this test period shall be no less than two hours in duration.

B. No more than 1000 feet of sewer pipe may be constructed at a time without testing.

C. If leakage exceeds the specified amount, the Contractor shall make the necessary repairs or replacements required to permanently reduce the leakage to within the specified limit, and the test shall be repeated until the leakage requirement is met.

D. When a standpipe and plug arrangement is used in the upper manhole of a line under test, there must be some positive method of releasing entrapped air in the sewer prior to taking measurements. In the case of sewers laid on steep grades, the length of the line to be tested by exfiltration at any one time may be limited by the maximum allowable internal pressure on the pipe and joints at the lower end of the line.

E. Where it is not feasible to conduct an exfiltration test, and the Contractor is able to demonstrate that the groundwater level is at least 1 ft. above the crown of pipe at the upper end of the section to be tested and the Contractor receives the approval of the Engineer, an infiltration test shall be conducted by the Contractor in the presence of the Engineer by isolating individual sewer sections as above and measuring the infiltrated flow in each section over a period of time. Each sewer section shall include the run of the main sewer between two manholes, the connection laterals leading to this main sewer, and the upstream manhole. The maximum infiltration shall not exceed 200 gallons per inch diameter per mile per day.

3.2 LOW PRESSURE AIR TEST - GRAVITY SEWERS

A. The low pressure air test shall be performed with AIR-LOC equipment manufactured by Cherne Industrial Inc., Hopkins, Minnesota; New Britain Prod., New Britain, Pa., or equal and shall be conducted under the supervision of the Engineer.

B. All wyes, tees, or ends of lateral stubs, shall be capped to withstand the internal test pressures. Caps shall be easily removable for future lateral connections or extensions.

C. After a manhole to manhole section of sewer has been backfilled and cleaned, it shall be plugged at each manhole with pneumatic plugs. The pneumatic plugs such that they will hold against the line test pressure without requiring external blocking or bracing. One of the plugs shall have three hose connections. Air for inflation of the triple connection pneumatic plug shall be supplied through a factory-equipped control panel. One hose shall be used for continuously reading the air pressure in the sealed line. The third hose shall be used for introducing low pressure air into the sealed line.

D. There shall be a 3 ½ " or larger diameter, 0-30 psi gauge mounted on the control panel for reading of the internal pressure in the line being tested. Calibrations from 0-10 psig portion shall cover 90% of the complete dial range.

E. Low pressure air shall be introduced into the sealed line until the internal air pressure reaching 4 psig greater than the average back pressure of any ground water that may be over the pipe. At least two (2) minutes shall be allowed for the air pressure to stabilize. After the stabilization period, the third hose shall be quickly disconnected from the control panel.

F. The portion of line being tested shall be accepted if the portion under test does not lose air at a rate greater than 0.003 cfm per square foot of internal pipe surface when tested at an average pressure of 3.0 psig greater than any back pressure exerted by the ground water that may be over the pipe at the time of the test.

G. The requirements shall be accomplished by performing the test as follows:

The time required in minutes for the pressure to decrease from 3.5 to 2.5 psig (greater than the average back pressure of any ground water over the pipe) shall not be less than the time shown for the given diameters in the following tables:

<u>Pipe Diameter in Inches</u>	<u>Minutes</u>
4	2.0
6	3.0
8	4.0
10	5.0
12	5.5
15	7.5

18	8.5
21	10.0
24	11.5

I. In areas where ground water is known to exist, the Contractor shall install a one-half inch diameter capped pipe nipple, approximately 10" long, through the manhole. This shall be done at the time the sewer line is installed. Immediately prior to the performance of the line acceptance test the ground water level shall be determined by removing the pipe cap, blowing air through the pipe nipple into the ground as to clear it, and then connecting a clear plastic tube to the pipe nipple. The hose shall be held vertically and a measurement of the height in feet of water shall be taken after the water stops rising in this plastic tube. The height in feet shall be divided by 2.3 to establish the pounds of pressure that will be added to all readings.

J. If leakage exceeds the specific amount, the Contractor shall make the necessary repairs or replacements required to permanently reduce the leakage to within the specified limit, and the test shall be repeated until the leakage requirement is met.

3.3 SEWER MAHOLE – VACUUM TESTING

A. Each manhole shall be tested immediately after assembly and prior to backfilling. All lift holes shall be plugged with an approved non-shrink grout. All pipes entering the manhole shall be plugged, taking care to securely brace the plug from being drawn into the manhole. The test head shall be placed at the inside of the top of the core section and the seal inflated in accordance with the manufacturers recommendations. A vacuum of 10 inches of mercury shall be drawn and the vacuum pump shut off. With the valves closed, the time shall be measured for the vacuum to drop to 9 inches. The manhole shall pass the test if the time is greater than those listed below:

<u>Depth of Manhole</u> <u>4 and 5 Foot Diameter</u>	<u>Maximum Allowable</u> <u>Time (sec)</u>
0-10'	60
10-15'	75
15-25'	90

If the manhole fails the initial test, necessary repairs shall be made with a non-shrink grout while the vacuum is still being drawn. Retesting shall proceed until a satisfactory test is obtained. Following satisfactory test results, the manhole may be backfilled.

3.4 SEWER LINE – MANDREL TESTING

Prior to testing all lines shall be flushed and jetted. A 5% maximum deflection test is required for the PVC Pipeline after final trench compaction has taken place but prior to paving. The test shall be conducted with a rigid mandrel (go no go) device cylindrical in shape and constructed with a minimum of nine or ten evenly spaced arms or prongs. The mandrel shall be hand pulled by the Contractor through all sewer lines. Any section of

sewer not passing the mandrel shall be uncovered and the Contractor shall reround or replace the sewer to the satisfaction of the Engineer and at the Contractor's expense. The excavation shall be mechanically compacted to a minimum of 95 percent and the pipe retested.

3.5 SEWER LINE – VIDEO INSPECTION OF LINES

The interior of all mainline pipe shall be video inspected during the following spring upon completion of all other tests and prior to final paving. The testing shall be done by a company specializing in this type of work. The camera shall be drawn through the pipe, with a color image projected upon a color video screen which includes a distance. All services shall be located a distance from the manhole on the tape. All imperfections should be noted on the tape. Two copies of the tape shall be furnished to the Owner. Any misalignments, imperfections, sags, or other unacceptable observations shall be corrected by the Contractor at his/her expense. If the line is not flushed properly and requires re-flushing the Contractor shall re-video the line.

4.0 MEASUREMENT AND PAYMENT

4.1 SANITARY SEWER MANHOLES

Sanitary sewer manholes will be measured by each manhole installed and paid for at the Contract unit bid price per each. Payment shall include all necessary labor, materials, and equipment required to satisfactorily complete the work, including excavation, crushed stone bedding, backfill, and watertight pipe connections.

4.2 SANITARY SEWER PIPE

PVC sanitary sewer pipe will be measured in feet, from end of pipe to end of pipe installed including fittings, and paid for at the Contract unit bid price per foot of the respective pipe item. Payment shall include all necessary labor, materials, and equipment required to satisfactorily complete the work, including excavation, removal and disposal of existing pipes within the same trench, crushed stone bedding, tees, wyes, and other fittings, geotextile fabric where required, trench check dams, the connection to existing or proposed sanitary sewer structures or pipes, fittings, backfill, and testing.

The Contractor shall match existing diameter of pipe unless otherwise noted on the contract drawings. Sanitary sewer services replaced that are 4 inches in diameter shall be paid for under Item 250.06.

Cleanout assemblies replaced on the Government Center property (119 School St) will be paid for under Item 250.06 per vertical foot of cleanout assembly furnish and installed. Measurement will be made from the centerline of the horizontal lateral, vertically to the end cap installed. No separate payment will be made for polyethylene pipe, fittings, concrete, sand, or other materials required to satisfactorily install the cleanout assembly to the specifications and detail drawings. Removing and resetting the existing cleanout

cover and frame will be considered incidental to this item. Covers and frames damaged due to Contractor's negligence or lack of care shall be replaced at the Contractor's expense.

Compensation for all materials and work for the stainless steel sleeving of sewer main and services as required and directed by the Engineer shall be considered included in the unit price for sewer main and service pipe of all diameters. No separate payment shall be made for the sleeving of sewer main or services which cross over water mains.

Chimneys will be paid for under the respective pipe diameter item per vertical foot of chimney no separate payment will be made for polyethylene pipe, fittings, concrete, sand or other materials required to satisfactorily install the chimney to the specifications and detail drawings. There will be no additional payment for cutting and plugging existing sanitary sewer lines as shown on the Contract Drawings.

Rock excavation when encountered in the trenching operation shall be paid for under Item 144.

<u>ITEM 220</u>	<u>DRAINAGE STRUCTURE ADJUSTED</u>	<u>EACH</u>
<u>ITEM 220.2</u>	<u>DRAINAGE STRUCTURE REBUILT</u>	<u>VERTICAL FOOT</u>
<u>ITEM 223</u>	<u>FRAME AND GRATE (OR COVER) REMOVED AND RESET</u>	<u>EACH</u>

The work to be performed under this Item shall conform to the relevant provisions of Section 220, supplemented by the following:

Structures to be adjusted shall be identified by the Contractor and approved by the Engineer prior to commencing with the work. Castings that are damaged due to the actions of the Contractor shall be replaced with new castings at his own expense. Structures that are adjusted will be paid for at the unit price per each, regardless of the number of times that structure is to be adjusted to a temporary or final grade. Payment for structures to be adjusted shall include modifications to the structure in line and/or grade of up to 3 feet. Adjustment of double inlet catch basins shall be counted as one unit.

If the Engineer determines that any castings require replacement, the Contractor shall install new castings as required under Items 221.1. If new castings are to be installed, payment for adjustment of the new castings shall be included under the item for the new casting.

Existing frames and grates or covers identified to be replaced shall be transported to the Public Works maintenance yard located at 169 Lexington St and stockpiled in a location identified by the engineer at no additional cost. Any frames and grates or covers determined by the Engineer to be of no further value to the City shall become the property of the Contractor and be disposed of off the project site by the Contractor without additional compensation.

Limits of drainage structures to be rebuilt shall be pre-approved by the Engineer. When in the judgment of the Engineer the masonry shows deterioration the structure shall be re-built in accordance with the provisions of Section 220.6.

Payment for the adjustment of structures shall include payment for all necessary labor, materials, and equipment required to satisfactorily complete the work, including removing and stacking existing castings to be replaced if required by the Engineer, initial setting of the new castings, adjustments to temporary grades, and adjustments to the final grade.

Drainage Structure Rebuilt will be measured by the vertical lineal foot, complete in place and will be paid for at the Contract unit price per foot, which price shall include all labor, materials, equipment and incidental costs required to complete the work including removal of deteriorated portions of the structure, brick, block and mortar as required to rebuild the structure.

ITEM 221.1 FRAME AND GRATE (OR COVER) - MUNICIPAL STANDARD EACH

The work to be performed under these Items shall conform to the relevant provisions of Sections 201 and 220, supplemented by the following:

Frames, grates and covers shall be LeBaron Foundry, Neenah Foundry or approved equivalent. The following model numbers refer to LeBaron products:

Frame and Cover for Drain and Sewer Manhole – LK 110A

Frames and Grates for Catch Basins and Gutter Inlets – LF 248.

Manhole covers shall have a diamond pattern; pick holes and the appropriate word “DRAIN” or “SEWER” cast in 3-inch letters to match the corresponding utility. Where 36” frames and covers are required, they shall be provided and installed at no additional cost. Casting frames shall be set in a full mortar bed with bricks, a maximum of 8 inches thick. All castings shall be set in a full concrete collar, conforming to Standard Detail 202.9.0.

Existing frames and grates or covers identified to be replaced shall be transported to a location within Waltham identified by the Engineer at no additional cost. Any frames and grates or covers determined by the Engineer to be of no further value to the City shall become the property of the Contractor and be disposed of off the project site by the Contractor without additional compensation.

Frames and grates (or covers) - municipal standard will be measured for payment per each, complete in place and will be paid for at the Contract unit price per each, which price shall include all labor, materials, equipment and incidental costs required to complete the work including initial setting of the new casting, adjustments to temporary grades, and adjustments to the final grade.

ITEM 290**SEWER FLOW CONTROL****LUMP SUM**

This section includes all the equipment, labor, and materials necessary to perform all work for sewer flow control for replacing existing sewers. Contractor is responsible for bypassing 100% of the existing flow during the performance of the work.

SUBMITTALS

Submit the following:

- A. Written description of flow control;
- B. Capacities of all equipment to be used, including standby equipment;
- C. Design calculations of peak flows in bypassed pipes; and
- D. Locations of temporary sewer plugs and bypass discharge lines

FLOW CONTROL PRECAUTIONS

When flow in a sewer line is plugged, blocked, or bypassed, sufficient precautions shall be taken to protect the sewer lines from damage that might result from sewer surcharging. Overflows or discharges onto the ground or into streams shall not be allowed.

COORDINATION

A. The Contractor shall completely remove and dispose of all dirt, debris, rubbish and surplus, and unsuitable materials at the end of each work day at no additional cost to the owner. Spoils shall not be stored or drained onto the ground or into local streams or waterbodies.

B. Whenever the Contractor desires to use a hydrant for water supply, the Contractor shall obtain the permission of the Owner. All costs associated with the use of water supplied from hydrants shall not be paid for separately but shall be deemed to be included in the bid. Operation of hydrant shall be in accordance with City Standards. Use of an RPZ device or air gap is required.

A sewer line plug shall be inserted into the line upstream of the section being worked. The plug shall be so designed that all or any portion of the sewage can be released. After the work has been completed, flow shall be restored to normal.

PUMPING AND BYPASSING

Provide the pumps, conduits, and other equipment to divert the flow of sewage around the section in which work is to be performed. The bypass system shall be of sufficient capacity to handle 1.25 times the maximum gravity flow of the pipeline section being bypassed. The Contractor shall provide all necessary labor and equipment to setup and operate the equipment in a manner to prevent all spills, overflows, and releases. This shall include manning the equipment continuously or providing auto-dialer equipped machinery for fail safe operation.

All pumps shall be equipped with sound attenuation measures which reduce noise levels to maximum of 75 decibels at a distance of 30 feet from the equipment during all periods of operation. If equipment is operated between the hours of 8:00 PM and 6:00 AM, this equipment shall also be provided with sound attenuation enclosure consisting of a three-sided enclosure with roof constructed of 2 x 4 lumber frame with ½-inch plywood sheathing and 2-inch Styrofoam panels attached to the inside of the entire enclosure. The enclosure shall be portable to allow the enclosure to be moved when bypass pumping equipment is moved.

Bypass pumping equipment shall include pumps, conduits, engines, and related equipment necessary to divert the flow of sewage around the section in which work is to be performed. In addition, the contractor shall maintain at the same location and in operable condition, spare equipment to be used in case there is equipment failure or extreme flows. The Contractor shall have necessary spare pumps available and connected such that it can operate immediately when levels rise due to extreme flows or duty pump failure.

PLUGGED OR BYPASSED SEWER LINES

Plugged or bypassed sewer lines shall not be allowed to overflow or discharge onto the ground or into streams. The maximum allowable level of surcharge in any sewer line during bypass pumping or plugging shall be 1 foot above the crown of the pipe, as measured in the first adjacent manhole upstream of the bypass pumping operation. Once flow levels exceed this depth, flow control measures shall be immediately removed by the Contractor from the sewer line until flows decrease or larger pumps are obtained by the Contractor.

The Contractor will be solely responsible for any legal actions taken by the state regulatory agencies if such overflows occur during construction.

The new sewer line may be used by the Contractor to carry the sanitary flows only after the new pipe has passed inspection and testing. Any “temporary” connections to the new sewer line shall be approved by the City Engineer

Sewer Flow Control shall be paid for as a lump sum. Payment for all flow control work, including the design of the pumping system, including any materials to construct including all, pumps, pipes, appurtenances and, all necessary equipment, materials and installation, piping, pumping, placement and/or removal of the system as outlined above, shall be at the Contract Unit Price for this Item. Such price shall be considered full compensation for materials, labor, equipment, tools, and incidentals necessary to complete the work to the satisfaction of the Engineer. The Engineer may issue percentages of the lump sum amount on each pay application respective to the Sewer Flow Control performed and yet to be performed under the Contract.

ITEM 347.1**1 INCH COPPER TUBING TYPE K****FOOT**

The Contractor shall install new water services and remove and dispose of existing water services as directed and in accordance with the relevant provisions of Section 140 and Section 300 of the Standard Specifications, amended and/or supplemented as follows:

Services shall be replaced with new 1 inch tubing up to the property line.

The depth of the service trench shall be at least 5 feet below the established finished grade and not more than 2.5 feet wide. All excavation, bedding and backfilling shall be included in the cost of the pipe.

Care shall be exercised to prevent dirt and other foreign matter from entering pipe and fittings. Corporation stops shall be left open (turned on) when the trench is backfilled.

The length of furnished and installed service pipe shall be measured beginning at the center of the corporation stop key. No deductions in length shall be made for curb stops or unions. to be paid for shall be measured by the foot, laid by the Contractor.

Payment shall be made at the Contract unit price per foot for furnishing and laying the service pipe complete in place and accepted by the Engineer. The prices shall include excavation, removing and disposing of existing services and unsuitable material from trenches, laying and connecting the new service, providing a three part union needed to connect the new service to the existing, fittings, goosenecks, bends, adapters, sand for bedding and backfill, 12" of gravel roadway subbase, and compactions.

Gravel borrow required to replace unsuitable backfill material as deemed by the Engineer shall be paid for under Item 151.

ITEM 358**GATE BOX ADJUSTED****EACH**

The work to be done under these Items shall conform to the relevant provisions of Section 301 and the following:

Gate boxes, including service boxes, to be adjusted shall be identified by the Contractor and approved by the Engineer prior commencing with the work. Gate boxes and service boxes that are adjusted will be paid for at the unit price per each, regardless of the number of times that structure is to be adjusted to a temporary or final grade.

Service boxes and gate boxes are to be kept accessible during the construction period for use in an emergency. Any existing boxes which are broken, damaged, or cannot be adjusted, shall be excavated to the depth of the existing gate valve and removed. The replacement box shall be set plumb at the same location. Gravel borrow backfill will be used and shall be thoroughly compacted with a power tamper. Adjustment to final grade shall be done just prior to placing the final pavement course or sidewalk material. Any castings determined by the Engineer to be of no further value to the Owner shall become the property of the Contractor and be disposed of off the project site by the Contractor

without additional compensation.

Payment for the adjustment of gate boxes shall be at the contract unit price per each, complete in place, which price shall be full compensation for all necessary labor, materials, and equipment required to satisfactorily complete the work, including adjustments to temporary grades and adjustments to the final grade.

Work under this item will only be accepted if the water crew is able to operate the valve after the box has been replaced and/or reset.

ITEM 363.1

1 INCH CORPORATION COCK

EACH

Under these items the Contractor shall furnish and install corporation cocks on all service lines as shown on the Plans and in accordance with the Relevant Provisions of Section 140 and Section 300 amended as follows.

Corporation cocks shall be of bronze, made from castings, the materials of which conform to ANSI/ASTM Standard Specification B61-76 or B62-76, latest issue.

Couplings shall be of bronze, made from castings, the material of which conforms to ANSI/ASTM Standard Specification B61-76 or B62-76, latest issue.

Each cock shall be individually tested under a hydrostatic head of 250 psi and a statement of the manufacturer shall be supplied to the Engineer prior to installation certifying that each stop supplied has been found to be watertight prior to leaving the factory.

Each corporation cock shall have a solid plug which freely operates and has a full, round, smooth, reamed waterway. Cocks shall have plugs hand ground into the body of the fittings. Cocks shall be opened by turning right, clockwise, and shall be marked on the fitting accordingly.

Corporation cocks shall be screwed firmly into the water mains. They shall be placed with the key upward and the inlet ends projecting at least 1/8 inch beyond the inside face of the main, unless otherwise permitted by the Engineer. All corporation cocks shall be easy turning, non-binding, open right and turned on before the trench is backfilled around them, so as to allow examination of connections for leaks.

All joints between cocks, fittings and service pipe shall be made watertight.

All corporation cocks for 1 inch service pipe shall be heavy pattern, solid plug, easy turning and meet the standards of the Water & Sewer Division. The inlet shall be an AWWA (CC) thread. The outlet shall be male iron pipe thread, one size larger than the inlet.

New services and services to be reconnected shall be joined to the water mains by means of a corporation stop inserted into a new tap in the main. The main, where service connections are necessary, shall be tapped by means of a tapping machine manufactured

for that purpose and furnished by the Contractor. The tap and drill of the tapping machine must be kept sharp. The taps generally shall be so located that the corporation stops, when inserted in a tap, will be at or above the horizontal diameter of the pipe and the service pipe must have a cover of at least 4 feet at all points. Any additional service pipe needed for the connection to the water mains shall be paid for under the appropriate service pipe item.

Payment shall be made at the contract unit price per each for furnishing and installing corporation cocks and such payment shall include connecting services to the new water mains; all drilling and tapping of the new mains; furnishing and installing new corporation stops, clamps, and couplings where required to connect the new services to the new corporation stops; all at locations directed on the Plans, or as required by the Engineer. Also included in these items is the abandoning of the existing corporation stops.

ITEM 381.01 **SERVICE BOX MUNICIPAL STANDARD** **EACH**

The work to be done under this Item shall conform to the relevant provisions of Section 300 of the Standard Specifications amended and supplemented as follows:

The Contractor shall furnish and install new service boxes as indicated on the Contract Drawings or as directed by the Engineer.

For purposes of standardization, service boxes on ¾" & 1" curb stops shall be standard 1" Erie style having an extra heavy cover with brass pentagon plug and 24" rod. 4 ½' to 5 ½' bury only. Service boxes on 1 ½" & 2" curb stops shall be standard 4" Buffalo sliding style having a brass pentagon cover nut with proper footpiece for curbstop valve 4 ½' to 5 ½' bury.

The new service boxes shall meet the requirements of the Water & Sewer Division and be the extendable type. The cover shall be counter sunk with a brass pentagonal plug that features a course "rope" thread to enable quick and easy removal.

The existing service boxes shall be removed and delivered to the Water & Sewer Division. If the Owner decides not to keep the castings the removal and disposal of the units will become the responsibility of the Contractor at no additional cost to the Owner.

Payment for the above shall be at the contract unit price per each, which price shall include full compensation for furnishing all labor, materials, tools and equipment necessary to complete the work and for furnishing and installing service boxes. Also included under this item is the removal and disposal of existing curb stops.

ITEM 384 **CURB STOP** **EACH**

The work to be done under this Item shall conform to the relevant provisions of Section 300 of the Standard Specifications amended and supplemented as follows:

The Contractor shall furnish and install new curb stops as indicated on the Contract

Drawings or as directed by the Engineer.

The existing curb stops shall be removed and disposed of by the Contractor. The new curb stops shall meet the requirements of the Waltham Water & Sewer Division. The curb stop shall have a quarter turn stop with check, solid tee head and no waste. Curb stops with plugged wastes will not be accepted. Curb stops shall open right (clockwise).

Payment for the above shall be at the contract unit price per each, which price shall include full compensation for furnishing all labor, materials, tools and equipment necessary to complete the work and for furnishing and installing curb stops. Also included under this item is the removal and disposal of existing curb stops.

If required by the Engineer, new service boxes shall be provided by the Water & Sewer Division.

The cost of resetting existing service boxes on new curb stops shall be considered incidental to the cost the curb stop.

ITEM 460

HOT MIX ASPHALT

TON

The work to be done under this Item shall conform to all the relevant provisions of Section 460 and the following:

Item 460 Hot Mix Asphalt, shall conform to the requirements of Section 560.00 of the current Edition of the "Standard Specifications for Highways and Bridges," Commonwealth of Massachusetts, Department of Public Works, including any addenda or amendments thereto. The City of Waltham has the option of requesting a modified state top when deemed necessary.

Bituminous concrete shall be spread at a temperature of not less than 225 degrees Fahrenheit and all initial rolling or tamping shall be performed when the temperature of the mixture is such that the sum of the air temperature plus the temperature of the mixture is between 300 and 375 degrees Fahrenheit. All mixtures shall be placed only when the atmospheric temperature is above 40 degrees Fahrenheit.

Bituminous concrete for wearing surfaces and base courses shall be spread in individual layers and compacted to the required lines, grades and cross section.

Rolling shall commence at the lower edges and shall progress toward the highest portion. Under no circumstances shall the center be rolled first. Each completed surface shall be thoroughly compacted, smooth and free from ruts, humps, depressions, or irregularities. Where new bituminous meets existing bituminous surfaces, an emulsifying agent shall be applied to seal the joint. A sand overcoat shall then be applied over the emulsifying agent.

All bituminous used for roadway and sidewalk bases and surfaces will be paid for on the basis of weight and shall be measured by tickets delivered with each load. The tickets shall be signed by a certified weigher and shall be countersigned by the OWNER. The

tickets shall clearly show the total, tare, and net weights. Loads represented by tickets not showing the weights as specified above will not be accepted for payment. Only bituminous concrete placed at the required depth and within the limits specified by the OWNER will be accepted for payment.

PAYMENT: Payment for bituminous concrete shall be made for the number of tons as determined above at the Contract unit price for ITEMS 460 as set forth in the Bid. Said price and payment shall be full compensation for all fine grading and compaction, for furnishing, spreading and compacting bituminous concrete, emulsifying and sanding of all joints, and for furnishing all tools, labor, materials, equipment, and all else incidental thereto.

ITEM 464

BITUMEN FOR TACK COAT

GALLON

The work to be done under this Item shall conform to all the relevant provisions of Section 400 and the following:

A tack coat of asphalt emulsion, grade RS-1 shall be uniformly applied to existing or new pavement surfaces prior to placing pavement courses as specified below. The existing surface shall be swept clean of all foreign matter and loose material using a mechanical sweeper and shall be dry before the tack coat is applied.

A pressure distributor shall be used to apply the tack coat. The tack distributor system shall be equipped with the following to control and monitor the application:

- System for heating the asphalt emulsion uniformly to specified temperature.
- Thermometer for measuring the asphalt emulsion temperature.
- Adjustable full circulation spray bar.
- Positive controls including tachometer, pressure gauge, and volume measuring device.

Tack Application Requirements.

The tack coat material shall be applied by a pressure distributor. All nozzles on the distributor shall be open and functioning. All nozzles shall be turned at the same angle to the spray bar. Proper nozzle angle shall be as determined by the manufacturer of the distributor spray bar. The spray bar shall be adjusted so that it is at the proper height above the pavement surface to provide a double overlap spray for a uniform coverage of the pavement surface. A double lap application requires that the nozzle spray patterns overlap one another such that every portion of the pavement receives spray from exactly two nozzles.

When an HMA pavement course is placed on an existing tight smooth pavement surface, a tack coat shall be applied at the rate of 1/20 gal/sy. All existing surfaces subjected to milling shall receive a tack coat at the rate of 1/15 gal/sy. Tack coat shall be applied to cover approximately 90% of the pavement surface.

Any new HMA pavement course that has been open to traffic, or that was placed 30 days

prior to placement of the subsequent pavement course, shall receive a tack coat at an application rate of 1/20 gal/s.y.

When the surface of a new HMA pavement course is in a condition which in the Engineer's judgment is unsatisfactory for the direct placement of the subsequent pavement course, a tack coat shall be applied at the applicable rate specified above for the particular pavement surface condition.

In addition to the requirements above, all vertical surfaces of cuts for patches, curbs, edging, utilities, and drainage structures shall receive a thorough tack coat application immediately prior to placing each HMA pavement course.

Tack Inspection.

The asphalt emulsion temperature and application rate shall be periodically measured. If the temperature or application rate is determined to not be in conformance with the specification requirements above, the Contractor shall make appropriate adjustments to the tack application operations.

METHOD OF MEASUREMENT

Item 464., Bitumen for Tack Coat, will be measured by the square yard and the quantity to be measured shall be the actual number of gallons of bitumen for tack coat applied to the as required by the Engineer. Bitumen for Tack Coat, will be paid for at the Contract unit price per gallon which shall include full payment for all labor, materials, equipment, fuel and incidentals to properly complete the work to the satisfaction of the Engineer.

ITEM 472.2 HOT MIX ASPHALT FOR PERMANENT PATCH (5") SQUARE YARD

The work to be done under this Item shall conform to all the relevant provisions of Section 472 and the following:

Item 472.2 Hot Mix Asphalt For Permanent Patch (5") shall consist of making roadway pavement repair patches on City roads. The areas for patching shall be identified by the Engineer. Areas to be patched shall be saw cut and the pavement removed, a gravel base of 12" compacted depth shall be installed and compacted hot mix asphalt shall be installed to be flush with the top of the adjacent roadway surface.

The bituminous concrete surface shall be laid in two courses to a depth after rolling of 5 inches. The binder course shall be 2.5 inches thick and parallel to the proposed grade of the finished surface. The top course shall be 2.5 inches in thickness after rolling and flush with the adjacent pavement surface.

In place of the 12" gravel base, excess reclaimed pavement borrow material may be used at no additional cost.

All areas that are to be patched as described above shall be marked out in the field and approved by the Engineer prior to excavation.

Payment for Item 472.2 shall be at the Contract unit price per square yard, complete in place, which price shall be full compensation for sawcutting, excavating, installation of the gravel base, compacting, grading, paving and all labor, equipment and materials necessary to complete the work.

ITEM 580

CURB REMOVED AND RESET

FOOT

The work to be done under these Items shall conform to the relevant provisions of Sections 501, 580, and the following:

The work under these items shall include saw cutting existing pavements, excavation, gravel foundation and backfilling, curbing, and cement concrete, as shown on the details. Removal and disposal of existing bituminous or concrete curbing shall be considered incidental to the installation of new curbing, and no separate payment will be made.

All new curb and edging will be paid for under Items 506 whether or not the pieces are curved or straight, no distinction made for curved pieces for payment purposes. Resetting of existing edging, curb inlet stones, splayed end transition stones, and wheelchair ramp transition stones shall be included under Item 580 – Curb Removed and Reset, and no additional payment will be made for the resetting of these curb stones.

All work requiring chamfering or cutting of curb or edging shall be considered incidental and shall be included in the unit bid price of the respective item. All existing curb or edging determined suitable for reuse on the project which is not reset at its present location shall be removed and stacked by the Contractor at a designated location within the City for further reuse on the project at such location or locations as directed by the Engineer. Costs of transporting and stacking all such curb or edging to be re-used on the project shall be included in the Contract bid price for Item 580 – Curb Removed and Reset as applicable.

All existing curb or edging that is not to be re-used on the project shall be transported to a location within City to be identified by the Engineer at no additional cost to the City. Any curb determined by the Engineer to be unsuitable for further reuse shall become the property of the Contractor and be disposed of off the project site by the Contractor without additional compensation.

New or existing curb stones may be used for wheelchair ramp transition curbs. Curbs shall be cut in such a way so that a flush joint is formed where the transition curb meets the adjacent curb at all locations. The length of the transition is to be in accordance with the Massachusetts Architectural Access Board's requirements.

Splayed end transition stones shall be used at vertical curb to sloped edging transitions and shall be as detailed on the plans.

The work under this item shall include placing a minimum of 6" of loam borrow and seeding disturbed areas beyond the edge of pavement and behind curbs and sidewalks, as directed by the Engineer.

Payment will be made at the Contract unit price per square yard of loam placed and seeded, and will include all necessary labor, equipment, and materials to satisfactorily complete the work including loam borrow, limestone, grass seed, and fertilizer.

ITEM 850

TRAFFIC CONTROL

LUMP SUM

The work to be done under this Item shall conform to the relevant provisions of Sections 751, 765, and the following:

The work to be done under this Item shall conform to the relevant provisions of Sections 800, 824, 828, 840, 850 and the following:

The Contractor shall furnish, illuminate, and maintain such signs as directed or as necessary for the safe and/or regulation convenience of traffic; shall provide, erect and maintain barricades, warning lights, etc. as needed or as directed to keep people and vehicles from equipment, obstacles, etc; and take such other reasonable means and precautions as the Engineer or the Owner may direct or as may be needed to prevent damage or injury to persons, vehicles, or other property, and to minimize the inconvenience and danger to the public by his/her occupancy of the street or highway or other areas of work. He/she shall arrange his/her operations and the spaces occupied by him/her, so far as possible, to provide access to property along the street, particularly driveways and entrances, to fire hydrants, manholes, gate boxes, etc., of other utilities. Whenever any equipment obstructs traffic in or to any public street, private driveway or property entrance, the Contractor shall take such means as may be necessary to maintain traffic and access so far as the requirements of this article are applicable, they shall also apply to work in private ways and public and private lands other than streets and highways. The Contractor shall confine his/her occupancy of public or traveled ways to the smallest spaces compatible with efficient performance of the work contemplated by the Contract, and particularly to such limits as may be set out in Drawings or Specifications.

ITEM 999.001

UNIFORMED POLICE DETAILS

SQUARE YARD

The Contractor shall provide such uniformed police officers (outside their regular tour of duty) as the Owner shall deem necessary to avoid, so far as reasonably possible, damage to the safety of persons and substantial interference with the free circulation of traffic. When so required by the Owner, the Contractor shall make all arrangements in obtaining police assistance. The Contractor shall pay the amount due for such assistance to the City of Waltham. The Contractor shall then be reimbursed by the City of Waltham. Police details may be arranged by calling (781) 314- 3604.

Uniformed officers required for purposes other than public safety and / or control of traffic

shall not be eligible for payment. Details billed to the Contractor due to cancellation of work will not be eligible for payment.

If uniformed policemen are required for traffic control, as determined by the Owner, the Contractor shall arrange for the police detail by contacting the Police Department at least 24 hours in advance of the time the detail will be required. The Contractor will be responsible for coordinating with the Police Department when details are required.

All bills for police details must be paid in full by the Contractor before reimbursement is made by the City of Waltham. Only bills stamped "PAID" by the City Treasurer's Office will be accepted by the Owner.

The Contractor shall pay to any police officer employed by him the prevailing rate of wage to special duty police officers (MGL Chapter 149, §34B). The quantity on the Bid form for ITEM 999.001 is an estimate for funding and bid comparison purposes. Payment to the Contractor for special duty police will be made at the rate established by the Waltham Police Department.

Payment shall be made by the Contractor within 30 days of billing. Failure to pay an outstanding bill within 30 days may result in a penalty charge to the Contractor for late payment. There will be no reimbursement for any penalties or late charges that may be assessed against the Contractor for late payment. Furthermore, the Owner will accept no further requests for payment if police detail bills are more than 30 days in arrears.

The Contractor will not be reimbursed for any detail that he fails to cancel when it is not required (work does not proceed as scheduled or due to inclement weather, etc.) Reimbursement will be entered in the next estimate for payment.

Reimbursement shall be made on all bills stamped "PAID" by the City of Waltham Treasurer's Office and presented to the Owner less any amount for unnecessary details not canceled by the Contractor when required.

Payment for special duty police will be made on a dollar for dollar basis as determined above for ITEM 999 as set forth in the Bid. Said price and payment shall be full compensation for furnishing all special duty police

END OF SECTION

**ATTACHMENT B
DRAWINGS**

PLANS SHOWING
KENMORE TERRACE SEWER REPLACEMENT
CITY OF WALTHAM, MASSACHUSETTS

OCTOBER 2020

PREPARED BY
CITY OF WALTHAM
CONSOLIDATE PUBLIC WORKS DEPARTMENT
WATER & SEWER DIVISION
169 LEXINGTON STREET
WALTHAM, MA 02452

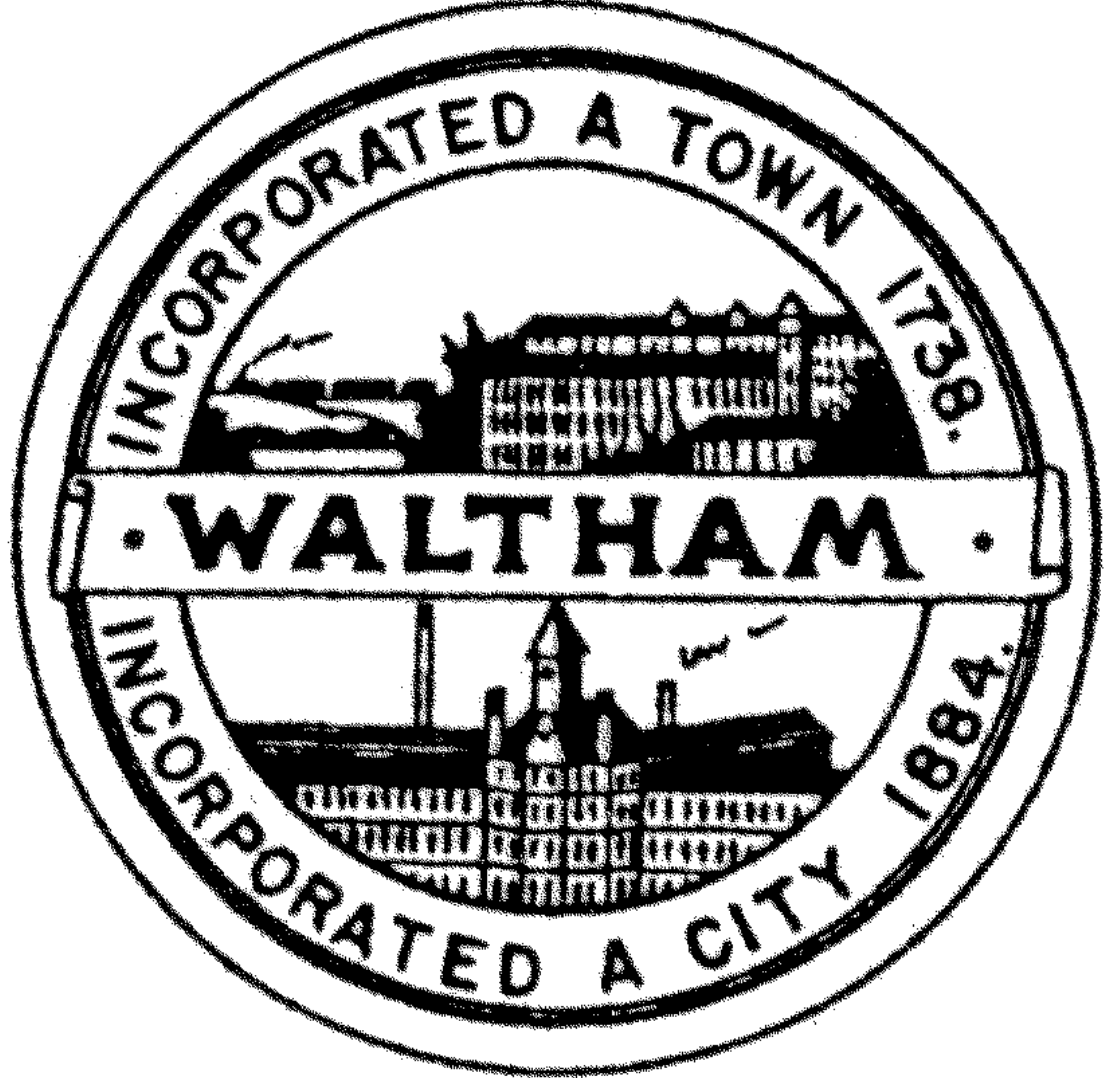

DRAWING INDEX

<u>SHEET NO.</u>	<u>DESCRIPTION</u>
1.	COVER SHEET
2.	CONSTRUCTION NOTES
3.	SEWER MAIN PLAN – KENMORE ROAD
4.	CONSTRUCTION DETAILS I
5.	CONSTRUCTION DETAILS II
6.	TRAFFIC DETAILS I
7.	TRAFFIC DETAILS II

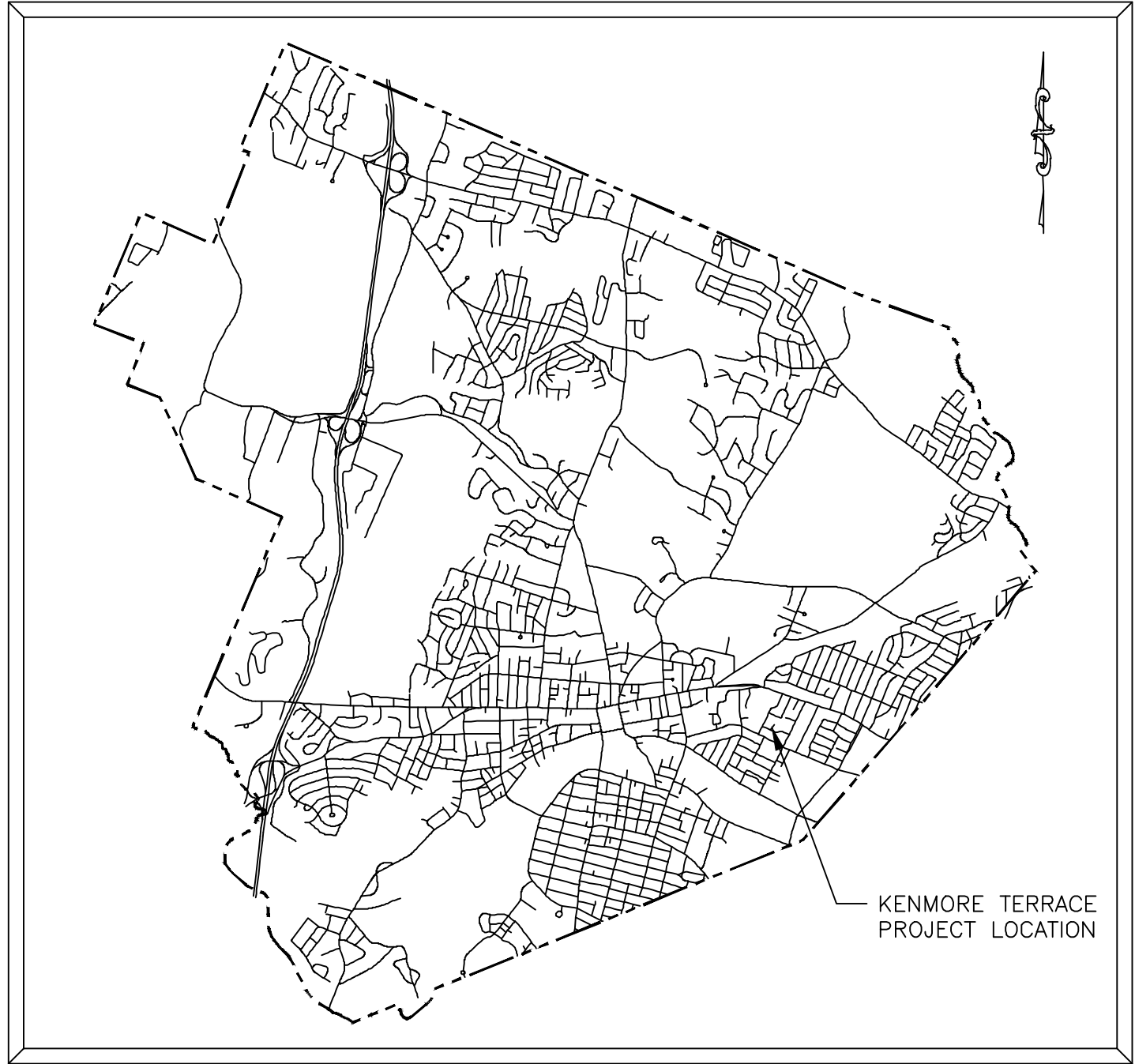

LOCUS MAP
1" = 4,000' +/-

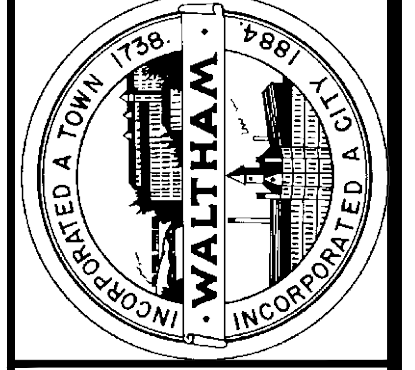

ABBREVIATIONS:

Table of abbreviations including AC (Asbestos Concrete), MB (Mail Box), ALT (Alternate), MH (Manhole), APPROX (Approximate), MIN (Minimum), BIT (Bituminous Concrete), N/F (Now or Formerly), BM (Benchmark), NTS (Not to Scale), BLDG (Building), OHW (Overhead Wire), BOL (Bollard), PC (Point of Curvature), BND (Bound), PROP (Proposed or Property), BRK (Brick), PT (Point of Tangency), CLDI (Cement Lined), PVC (Polyvinyl Chloride), DUCTILE IRON, REC (Record), CLF (Chain Link Fence), RET WALL (Retaining Wall), CMP (Corrugated Metal Pipe), ROW (Right of Way), CONC (Concrete), SB (Stone Bound), DH (Drill Hole), SMH (Sewer Manhole), DI (Ductile Iron), SN (Sign), DMH (Drain Manhole), STA (Station), DRV (Driveway), SW (Sidewalk), EMH (Electric Manhole), TBM (Temporary Benchmark), EX (Existing), TEMP (Temporary), FNC (Fence), TMH (Telephone Manhole), FND (Found), TP (Test Pit), EOP (Edge of Pavement), TYP (Typical), GG (Gas Gate), UNK (Unknown), GIP (Galvanized Iron Pipe), UP (Utility Pole), GRAV (Gravel), VC (Vitrified Clay), GS (Gas Service), VCC (Vertical Concrete Curb), HOR (Horizontal), VGC (Vertical Granite Curb), HSE (House), W/ (With), HYD (Hydrant), WCR (Wheelchair Ramp), HW (Headwall), WG (Water Gate), INV (Invert), WMH (Water Manhole), LP (Light Pole), WSO (Water Shutoff)

EXISTING LEGEND

Legend for existing features including EX. CATCH BASIN OR DRAIN INLET, EX. DRAIN MANHOLE, EX. SEWER MANHOLE, EX. HYDRANT, EX. WATER GATE VALVE, EX. WATER REDUCER, EX. GAS GATE VALVE, EX. UTILITY POLE, BUILDING (APPROX. LOCATION), APPROX. LOT LINE, EXISTING 10' CONTOURS, EXISTING 2' CONTOURS, EX. DRAIN LINE, EX. SEWER LINE, EX. WATER LINE, EX. OVERHEAD WIRE, EX. GAS LINE

PROPOSED LEGEND

Legend for proposed features including PROP. WATER HYDRANT, PROP. WATER GATE VALVE, PROP. WATER SHUT OFF, PROP. WATER REDUCER, PROP. CAP UTILITY LINE, PROP. TEMP. HYDRANT, PROP. WATER LINE, PROP. TEMP. WATER BYPASS, PROP. SEWER SERVICE, PROP. WATER SERVICE

GENERAL NOTES:

- 1. PLAN INFORMATION IS BASED UPON INFORMATION OBTAINED FROM THE CITY OF WALTHAM'S GIS DATA AND IS APPROXIMATE ONLY.
- 2. BUILDING LOCATIONS, AS SHOWN, ARE APPROXIMATE AND FOR REFERENCE PURPOSES ONLY.
- 3. DISTANCES SHALL NOT BE SCALED OFF OF THESE PLANS.
- 4. PRIOR TO THE PROPOSED CONSTRUCTION, THE CONTRACTOR SHALL PROVIDE THE ENGINEER AND CITY WITH A CONSTRUCTION SCHEDULE DELINEATING THE SEQUENCE OF WORK AND ESTIMATED TIME OF COMPLETION FOR EACH SEGMENT OF WORK.
- 5. THE CONTRACTOR SHALL SUBMIT A TRAFFIC MANAGEMENT PLAN TO THE CITY FOR REVIEW AND APPROVAL. THE PLAN SHALL BE IN COMPLIANCE WITH MASSACHUSETTS DEPARTMENT OF TRANSPORTATION (MASSDOT) AND THE MANUAL ON UNIFORM TRAFFIC CONTROL DEVICES (MUTCD).
- 6. THE CONTRACTOR SHALL MAINTAIN CONTINUOUS TRAFFIC FLOW DURING CONSTRUCTION SATISFACTORILY TO THE THE ENGINEER AND THE CITY OF WALTHAM.
- 7. ALL CONSTRUCTION SIGNING SHALL CONFORM TO THE REQUIREMENTS OF MASSDOT AND MUTCD.
- 8. THE CONTRACTOR SHALL BE SOLELY RESPONSIBLE FOR CONSTRUCTION MEANS, METHODS, TECHNIQUES, PROCEDURES, AND FOR SAFETY PRECAUTIONS AND PROGRAMS IN CONNECTION WITH ALL WORK INCLUDED UNDER THIS CONTRACT. THE DRAWINGS DO NOT INCLUDE NECESSARY COMPONENTS FOR CONSTRUCTION SAFETY. THE CONTRACTOR SHALL BE SOLELY RESPONSIBLE FOR PROVIDING AND MAINTAINING ALL SAFETY BARRIERS, WARNING FLASHERS, ETC., AS REQUIRED BY THE CONDUCT OF THE WORK FOR THE PROTECTION OF WORKERS AND NON-WORKERS ALIKE. THE CONTRACTORS ATTENTION IS DIRECTED TO OSHA REQUIREMENTS.
- 9. ALL CONSTRUCTION MATERIAL, DEBRIS, ASPHALT, SOIL, ETC. REMOVED FROM THE SITE SHALL BECOME PROPERTY OF THE CONTRACTOR. THE CONTRACTOR WILL BE RESPONSIBLE FOR TRANSPORTING AND DISPOSING ALL EXCESS MATERIALS IN ACCORDANCE WITH LOCAL, STATE, AND FEDERAL REGULATIONS.
- 10. THE CONTRACTOR SHALL BE RESPONSIBLE FOR THE SITE RESTORATION AND CLEAN UP UPON COMPLETION OF THE PROJECT. DURING THE COURSE OF CONSTRUCTION, ANY DAMAGE BY THE CONTRACTOR TO FENCES, GUARDRAILS, PATHS, STAIRS, PAVEMENT, LANDSCAPING OR VEGETATION SHALL BE REPAIRED OR REPLACED AND RESTORED TO ORIGINAL CONDITION AT NO ADDITIONAL COST TO THE CONTRACT. ANY REPLACEMENT FENCE AND/OR HANDRAILS MUST MATCH EXISTING.
- 11. TRENCH DEWATERING COSTS THROUGHOUT THE DURATION OF THE PROPOSED PROJECT SHALL BE INCLUDED IN THE APPLICABLE BID. A TRENCH DEWATERING PLAN SHALL BE SUBMITTED TO THE CITY ENGINEER FOR APPROVAL.
- 12. ALL CASTINGS, GATE BOXES, HYDRANTS, LIGHT POLES, ETC. DAMAGED DURING CONSTRUCTION SHALL BE SUPPLIED AND REPLACED BY THE CONTRACTOR AT NO ADDITIONAL COST TO THE CONTRACT.
- 13. THE CONTRACTOR SHALL BE RESPONSIBLE FOR RESETTLE ALL EXISTING PROPERTY MONUMENTATION THAT IS DISTURBED BY CONSTRUCTION OPERATIONS AT NO EXPENSE TO THE OWNER. THIS WORK IS TO BE DONE BY A PROFESSIONAL LAND SURVEYOR LICENSED IN THE COMMONWEALTH OF MASSACHUSETTS. PROPERTY BOUNDS FOUND ARE SHOWN ON LAYOUT PLANS, THIS MAY NOT BE INCLUSIVE OF ALL BOUNDS THAT EXIST IN THE PROJECT AREA. IF ANY ADDITIONAL BOUNDS ARE FOUND, THE CONTRACTOR SHALL DOCUMENT THE LOCATION AND CONTACT THE ENGINEER.
- 14. THE CONTRACTOR SHALL TAKE SPECIAL CARE NOT TO DAMAGE TREES WITHIN THE CONSTRUCTION AREA UNLESS THEY ARE NOTED TO BE REMOVED.
- 15. THE CONTRACTOR IS RESPONSIBLE TO NOTIFY AND COORDINATE SUPPORT WITH OWNERS OF UTILITY POLES WITHIN 10 FEET OF THE PROPOSED UTILITY PIPE CENTERLINE OR AS DIRECTED BY THE ENGINEER.
- 16. POLICE DETAILS SHALL BE COORDINATED BY THE CONTRACTOR.
- 17. THE CONTRACTOR SHALL BE RESPONSIBLE FOR PREVENTING ANY DEBRIS, SEDIMENT, OR SILTY WATER FROM ENTERING ANY DRAINAGE SYSTEM DURING ALL PHASES OF CONSTRUCTION. THE CONTRACTOR SHALL INSTALL TEMPORARY CATCH BASIN SILT SACKS AS REQUIRED BY THE ENGINEER.
- 18. CONSTRUCTION HOURS SHALL OCCUR BETWEEN THE HOURS OF 7:00 AM AND 5:00 PM, MONDAY THROUGH FRIDAY. WEEKEND WORK MUST BE APPROVED AT LEAST 48 HOURS IN ADVANCE BY THE CITY.
- 19. THE CONTRACTOR SHALL BE RESPONSIBLE FOR OBTAINING ALL PERMITS REQUIRED FOR THE COMPLETION OF THE WORK.

STOCKPILED MATERIALS & EQUIPMENT NOTES:

- 1. THE CONTRACTOR IS RESPONSIBLE FOR COORDINATING A LOCATION FOR STAGING AND STORING STOCKPILED MATERIALS AND EQUIPMENT.
- 2. THE CONTRACTOR IS RESPONSIBLE FOR COORDINATION OF LOCATION AND ANY PRIVATE AGREEMENTS AND ALL FEES THAT MAY BE ASSOCIATED WITH THE USE OF AN AREA FOR STORING STOCKPILED MATERIALS AND EQUIPMENT.
- 3. THE CITY OF WALTHAM IS NOT RESPONSIBLE FOR PROVIDING A LOCATION FOR STAGING OR THE STORING OF STOCKPILED MATERIALS AND EQUIPMENT.
- 4. MATERIALS SHALL NOT BE STOCKPILED WITHIN THE ROADWAY OR IN PUBLIC PARKING AREAS.
- 5. NO EQUIPMENT SHALL BE ALLOWED TO BE PARKED WITHIN THE ROADWAY WHILE NOT IN USE.
- 6. ALL SURPLUS EXCAVATED MATERIALS SHALL BE THE RESPONSIBILITY OF THE CONTRACTOR TO DISPOSE OF OFFSITE IN ACCORDANCE WITH ALL FEDERAL, STATE, AND LOCAL REGULATIONS.

PROPOSED WATER SYSTEM NOTES:

- 1. LOCATION OF PROPOSED WATER SYSTEM MAY BE ALTERED IN THE FIELD BY THE ENGINEER TO SUIT FIELD CONDITIONS.
- 2. ALL NEW GRAVITY SANITARY SEWER PIPE AND FITTINGS SHALL BE PVC PIPE, SDR-35 IN CONFORMANCE WITH A.S.T.M. D-3034.
- 3. ALL FITTINGS, ADAPTERS, COUPLINGS, CAPS, ETC. ASSOCIATED WITH THE PROPOSED SEWER SYSTEM SHALL BE INCLUDED FOR PAYMENT IN THE ASSOCIATED PIPE ITEM.
- 4. ALL PRECAST MANHOLES SHALL CONFORM TO THE LATEST A.S.T.M. C478 SPECIFICATIONS FOR PRECAST REINFORCED CONCRETE SECTIONS. CONCRETE SHALL HAVE A MINIMUM COMPRESSIVE STRENGTH OF 4,000 P.S.I. REINFORCING STEEL SHALL CONFORM TO THE LATEST A.S.T.M. A185 SPECIFICATIONS. ALL STRUCTURES SHALL BE CAPABLE OF SUPPORTING H-20 LOADING.
- 5. MANHOLES SHALL HAVE A BRICK PAVED SHELF AND INVERT CONSTRUCTED TO CONFORM TO THE SIZE OF PIPE AND FLOW AT CHANGES OF DIRECTION. THE INVERT SHALL BE LAID OUT IN CURVES OF THE LONGEST RADIUS POSSIBLE TANGENT TO THE CENTERLINE OF THE SEWER PIPES. SHELVES SHALL BE CONSTRUCTED TO THE ELEVATION OF THE HIGHEST PIPE CROWN AND SLOPED TOWARD THE FLOWING TROUGH CHANNEL. UNDERLAY OF INVERT AND SHELF SHALL CONSIST OF 3,000 P.S.I. CONCRETE FILL AND BRICK MASONRY. BRICK INVERT SHALL BE SLOPED TO PROVIDE SMOOTH TRANSITION FROM INLET TO OUTLET.
- 6. WHEN THE DIFFERENCE IN ELEVATION BETWEEN INLET AND OUTLET PIPES IS GREATER THAN 2 FEET AT MANHOLES, INSIDE OR OUTSIDE DROPS ARE REQUIRED.
- 7. WHEN A MANHOLE DEPTH IS LESS THAN 6 FEET, A REINFORCED CONCRETE SLAB COVER MAY BE USED IN LIEU OF CONE SECTION. REINFORCED CONCRETE SLAB SHALL HAVE AN ECCENTRIC ENTRANCE OPENING AND CAPABLE OF SUPPORTING H-20 LOADING.
- 8. CONCRETE COLLARS TO BE CLASS 3,000 P.S.I. CEMENT CONCRETE MASONRY.
- 9. ALL MANHOLES SHALL BE DAMPPROOFED WITH BITUMASTIC COATING.
- 10. PROPOSED PIPE AND MANHOLE LOCATIONS ARE APPROXIMATE AND MAY BE ALTERED IN THE FIELD TO BEST SUIT FIELD CONDITIONS AT THE DISCRETION OF THE ENGINEER.
- 11. WHEN THE HORIZONTAL SEPARATION BETWEEN THE NEW SEWER AND/OR THE EXISTING, NEW, OR RELOCATED WATER MAIN IS LESS THAN 10 FEET AND WHEN THE VERTICAL SEPARATION IS LESS THAN 18 INCHES, BOTH PIPES SHALL BE ENCASED IN CONCRETE FOR A MINIMUM OF 10 FEET. THE PROPOSED PIPE SHALL BE LAID IN SUCH A MANNER AS TO KEEP THE PIPE JOINTS AT A MAXIMUM DISTANCE FROM THE WATER MAIN.
- 12. TERMINUS MANHOLES SHALL BE LOCATED NO MORE THAN 5 FEET UPSTREAM OF THE LAST SERVICE CONNECTION ON THE LINE.
- 13. NEW SEWER SERVICE CONNECTIONS SHALL BE INSTALLED SUCH THAT THEY ARE BENEATH THE WATER MAIN AND WATER SERVICE CONNECTIONS WHILE MAINTAINING 5 FEET MINIMUM DEPTH OF COVER.
- 14. EXISTING SEWER SERVICES WHICH CONNECT INTO MANHOLES SHALL BE REPLACED AND RELOCATED, WHERE PRACTICABLE, TO CONNECT INTO THE SEWER MAIN AS DIRECTED BY THE ENGINEER.
- 15. THE HORIZONTAL PORTION OF ALL SEWER SERVICES ALONG SCHOOL STREET WITHIN STATION 0+00 THROUGH 7+73 SHALL BE REPLACED UNLESS NOTED AS EXISTING PVC. THE RESPECTIVE CHIMNEY PORTIONS OF EACH SERVICE ARE TO BE CCTV INSPECTED BY THE CONTRACTOR. CCTV INSPECTION OF CHIMNEYS SHALL BE PAID FOR UNDER ITEM 299.98. CHIMNEY CONNECTIONS FOUND TO BE IN GOOD CONDITION ARE TO BE LINED AS DETERMINED BY THE ENGINEER. LINING OF CHIMENYS SHALL BE PAID FOR UNDER ITEM 299.99. CHIMNEY CONNECTIONS FOUND TO BE IN POOR CONDITION SHALL BE REPLACED BY THE CONTRACTOR AT THE DIRECTION OF THE ENGINEER. REPLACEMENT OF CHIMNEYS SHALL BE PAID FOR UNDER ITEM 250.06.
- 16. ALL SEWER SERVICE / CHIMNEY REPLACEMENTS SHALL BE COMPLETED PRIOR TO THE CIPP LINING OF THE SEWER MAINS.

PROPOSED SANITARY SEWER SERVICE NOTES:

- 1. ALL NEW GRAVITY SANITARY SEWER SERVICES SHALL BE PVC PIPE, SDR-35 IN CONFORMANCE WITH ASTM D-3034.
- 2. THE CONTRACTOR IS RESPONSIBLE TO DETERMINE THE LOCATION OF THE EXISTING SEWER SERVICES AT THE PROPERTY LINE FOR CONNECTION TO THE EXISTING MAIN.
- 3. THE CONTRACTOR SHALL PERFORM TEST PITS, AS DIRECTED BY THE ENGINEER, TO VERIFY IN THE FIELD THE MATERIAL OF EXISTING SEWER SERVICES. SERVICES FOUND TO BE COMPRISED OF AN UNDESIRABLE MATERIAL SHALL BE REPLACED FROM THE MAIN TO THE PROPERTY LINE BY THE CONTRACTOR.
- 4. ALL FITTINGS, ADAPTERS, COUPLINGS, CAPS, ETC. ASSOCIATED WITH THE PROPOSED SEWER SERVICE REPLACEMENTS SHALL BE CONSIDERED INCLUDED IN THE COMPENSATION UNDER THE ASSOCIATED PIPE ITEM.

PROPOSED WATER SERVICE NOTES:

- 1. ALL EXISTING WATER SERVICES FOUND CONSISTING OF A MATERIAL OTHER THAN TYPE K COPPER TUBING SHALL BE REPLACED UP TO THE PROPERTY LINE.
- 2. ALL NEW WATER SERVICES, CORPORATIONS AND CURB STOPS SHALL BE SIZED AS SHOWN ON THE PLANS UNLESS OTHERWISE DIRECTED BY THE ENGINEER.
- 3. ALL NEW CORPORATIONS AND CURB STOPS SHALL BE LEAD FREE AND BALL TYPE WITH INSERTS AND RESTRAINTS.
- 4. LOCATION OF PROPOSED WATER SYSTEM MAY BE ALTERED IN THE FIELD BY THE ENGINEER TO SUIT FIELD CONDITIONS.

UTILITY NOTES:

- 1. PRIOR TO CONSTRUCTION, ALL UTILITIES, PUBLIC AND PRIVATE MUST BE NOTIFIED (SEE MASSACHUSETTS GENERAL LAWS, CHAPTER 82 SECTION 40.) ALL "DIG SAFE" - 811, OR CUSTOMER SERVICE - 1 (888) 344-7233.
- 2. THE CITY OF WALTHAM IS NOT A PART OF "DIG SAFE". THE CONTRACTOR MUST SEPARATELY CONTACT THE WATER AND SEWER DEPARTMENT AND WIRES DEPARTMENT FOR APPROPRIATE MARK OUTS.
- 3. SUBSURFACE AND OVERHEAD UTILITY LINES, AS SHOWN HERON, WERE COMPLIED ACCORDING TO CITY OF WALTHAM GIS INFORMATION. THE LOCATIONS ARE APPROXIMATE ONLY. ACTUAL LOCATIONS MUST BE DETERMINED IN THE FIELD. THE CITY OF WALTHAM ASSUMES NO RESPONSIBILITY FOR DAMAGES INCURRED AS A RESULT OF UTILITIES OMITTED OR INACURATELY SHOWN. THE CONTRACTOR SHALL EXCAVATE TEST PITS TO VERIFY UTILITY LINE LOCATIONS AS NECESSARY.
- 4. UNLESS OTHERWISE INDICATED, WATER MAINS ARE ASSUMED TO BE 5 FEET BELOW THE EXISTING GROUND SURFACE. GAS LINES ARE ASSUMED TO BE TO BE 3 FEET BELOW THE EXISTING GROUND SURFACE. TELEPHONE AND ELECTRIC CONDUIT ARE ASSUMED TO BE 2 FEET BELOW THE EXISTING GROUND SURFACE.
- 5. DAMAGE TO ANY UTILITY WILL BE REPAIRED BY THE CONTRACTOR, AT THE CONTRACTOR'S EXPENSE, IN A TIMELY MANNER SO THAT DISRUPTION OF SERVICE TO ANY UTILITY WILL NOT BE LONGER THAN PRACTICALLY NECESSARY TO REPAIR THE DAMAGE.
- 6. THE CONTRACTOR SHALL EXCAVATE TEST PITS TO VERIFY UTILITY LINE LOCATIONS AND DETERMINE ACTUAL FIELD CONDITIONS AS NECESSARY OR AS DIRECTED BY THE ENGINEER. THE CONTRACTOR SHALL PLAN AND PERFORM TEST PIT EXCAVATION WELL IN ADVANCE OF COMMENCING CONSTRUCTION IN THE GENERAL AREA TO ALLOW TIME TO REVIEW ACTUAL CONDITIONS ENCOUNTERED. TEST PITS NOT SPECIFICALLY IDENTIFIED SHALL BE EXCAVATED BY THE CONTRACTOR AT THE DIRECTION OF THE ENGINEER. PAYMENT SHALL BE INCLUDED UNDER THE APPLICABLE ITEM.
- 7. EXISTING UTILITIES INTERFERING WITH THE WORK SHALL BE RELOCATED OR BRACED AND SUPPORTED AS DIRECTED IN THE FIELD BY THE ENGINEER, UNLESS OTHERWISE INDICATED OR SPECIFIED.
- 8. UTILITY CONTACTS:
THE CITY OF WALTHAM - WATER/SEWER/DRAIN
WATER & SEWER FOREMAN (7AM-3PM): 781-314-3826
DAYTIME OFFICE: 781-314-3820
AFTER HOURS EMERGENCY: 781-893-3700
THE CITY OF WALTHAM - WIRES DEPARTMENT
TIM KELLY, INSPECTOR OF WIRES: 781-389-6044
VERIZON - TELEPHONE
FREDERICK WAGNER, AREA PROJECT COORDINATOR: 781-376-5067
COMCAST - CABLE
MANUEL FURTADO, AREA PROJECT COORDINATOR: 774-644-9104
NATIONAL GRID - GAS
KEITH WALTERS, AREA PROJECT COORDINATOR: 516-924-4602
EVERSOURCE - ELECTRIC
N.E. SERVICE NUMBER: 800-592-2000

TRENCH PAVING NOTES:

- 1. ALL TRENCHES SHALL BE BROUGHT TO GRADE AT THE END OF EACH WORKDAY. ALL TRENCHES SHALL BE PAVED WITH 3" TEMPORARY BINDER PAVEMENT AT THE END OF EACH WORK WEEK (SEE DETAILS). AFTER A MINIMUM OF 30 DAY SETTLEMENT PERIOD THE CONTRACTOR SHALL INSTALL THE REMAINING 2" OF TEMPORARY TOP COURSE PAVEMENT ALONG TRENCHES.
- 2. THE CONTRACTOR SHALL LIMIT THE USE OF STEEL PLATES IN THE ROADWAY. STEEL PLATES LEFT WITHIN THE ROADWAY SHALL BE PINNED AND PATCHED AROUND USING BITUMINOUS CONCRETE.
- 3. ALL TEMPORARY AND PERMANENT TRENCHES IN EXISTING PAVEMENT ARE TO BE SAW CUT WHERE THE PROPOSED PAVEMENT SHALL MEET TO ALLOW A SMOOTH TRANSITION AFTER PAVING. NO OTHER METHOD OF CUTTING IS ACCEPTABLE. JOINTS SHALL BE SANDED AND SEALED.
- 4. ALL TRENCHES SHALL BE COMPACTED BY MECHANICAL EQUIPMENT, PUDDLED OR JETTED WITH WATER TO ALLOW FOR PROPER SETTLEMENT. TRENCHES THAT CANNOT BE JETTED WILL BE MECHANICALLY COMPACTED AS DETERMINED BY THE ENGINEER. ALL TRENCHES SHALL BE COMPACTED TO 95% OF MODIFIED PROCTOR DENSITY. THE ENGINEER RESERVES THE RIGHT TO HAVE COMPACTION TESTING DONE AT THE CONTRACTOR'S EXPENSE.
- 5. AFTER COMPACTION IS COMPLETED, THE CONTRACTOR SHALL PLACE TRENCH PAVEMENT AS SHOWN ON THE DETAILS.
- 6. THE CONTRACTOR SHALL REMOVE AND REPLACE ALL PAVEMENT DAMAGED DURING THE INSTALLATION OF THE PROPOSED UTILITY.

EROSION & SEDIMENT CONTROL NOTES:

- 1. THE CONTRACTOR SHALL COMPLY WITH EROSION AND SEDIMENTATION CONTROL DETAILS AND NOTES AS SHOWN IN THESE CONTRACT DRAWINGS.
- 2. SILT SACKS SHALL BE INSTALLED AT ALL CATCH BASINS WITHIN THE PROJECT AREA PRIOR TO THE COMMENCEMENT OF WORK. SILT SACKS SHALL BE KEPT FREE OF SEDIMENT AND DEBRIS. SILT SACKS SHALL BE INSPECTED ON A DAILY BASIS OR IMMEDIATELY AFTER A RAIN EVENT. THE CONTRACTOR SHALL CLEAN SILT SACKS WITHIN 24 HOURS ONCE DIRECTED BY THE ENGINEER.
- 3. THE CONTRACTOR SHALL REPAIR ALL ERODED AREAS AND ENSURE A GOOD STAND OF TURF IS ESTABLISHED THROUGHOUT. THE CONTRACTOR SHALL REPAIR ALL ERODED OR DISPLACED RIPRAP, AND CLEAN SEDIMENT COVERED STONES.
- 4. THE CONTRACTOR SHALL PERFORM STREET SWEEPING AT THE END OF EACH DAY.

REVISION DATE:

DRAWN BY: IAM	DESIGNED BY: IAM	REVIEWED BY: IAM	APPROVED BY: MCC
---------------	------------------	------------------	------------------

DATE: 10/28/20
SCALE: N.T.S.
FILE: KENMORETSEWER
SHEET 2 OF 7

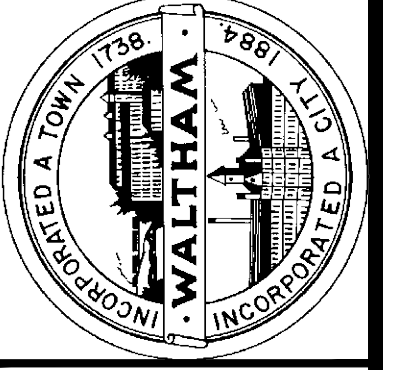

CITY OF WALTHAM ENGINEERING DEPARTMENT
 KENMORE TERRACE
 SEWER MAIN REPLACEMENT

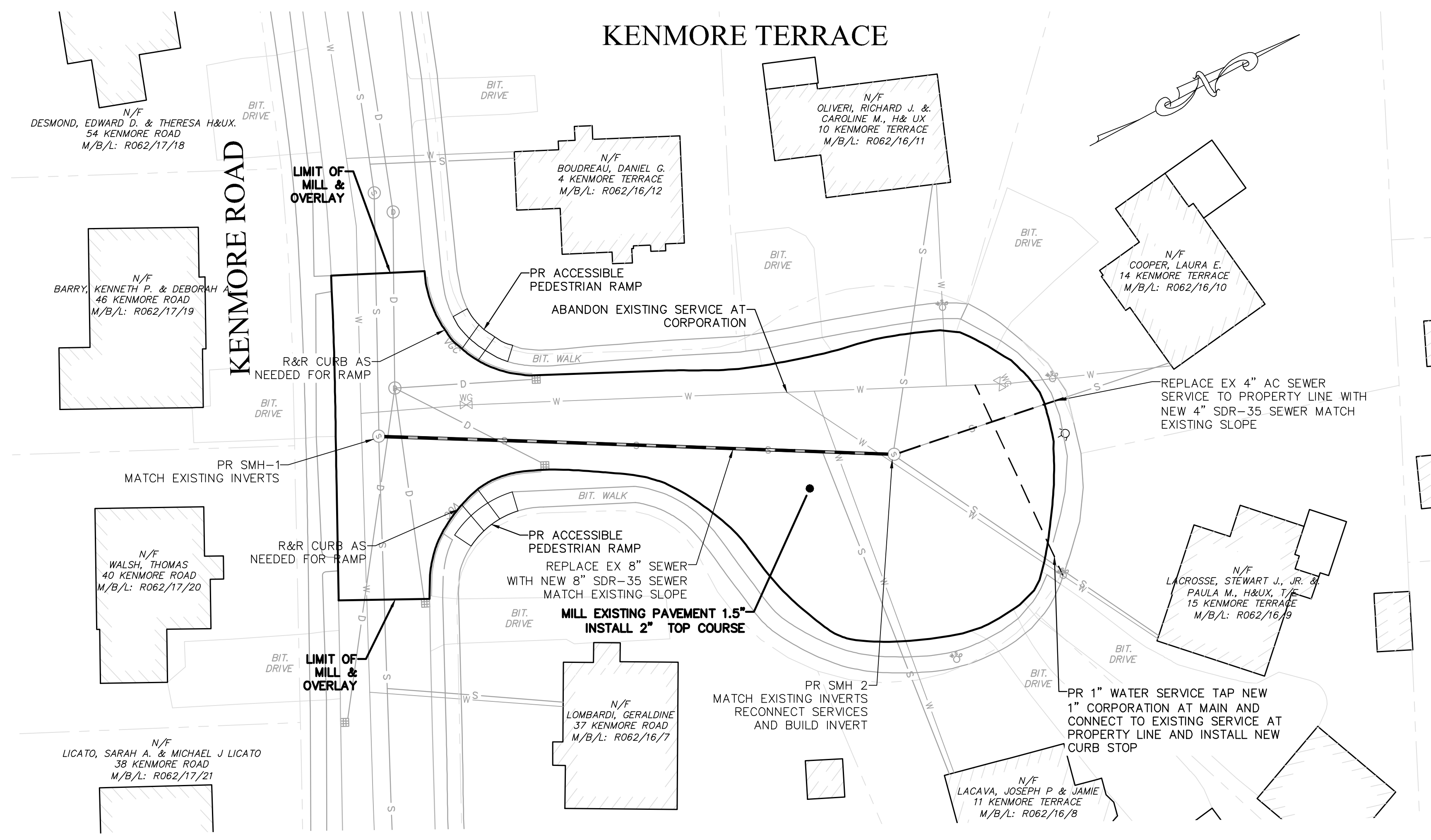

PLAN VIEW
 SCALE: 1" = 20'

DATE: 10/28/20	DRAWN BY: IAM	REVISION DATE:
SCALE: 1" = 20'	DESIGNED BY: IAM	
FILE: KENMORETERSEWER	REVIEWED BY: IAM	
SHEET 3 OF 7	APPROVED BY: MCC	

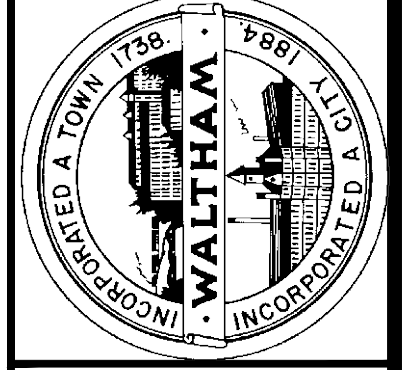

CITY OF WALTHAM ENGINEERING DEPARTMENT
 KENMORE TERRACE
 SEWER MAIN REPLACEMENT

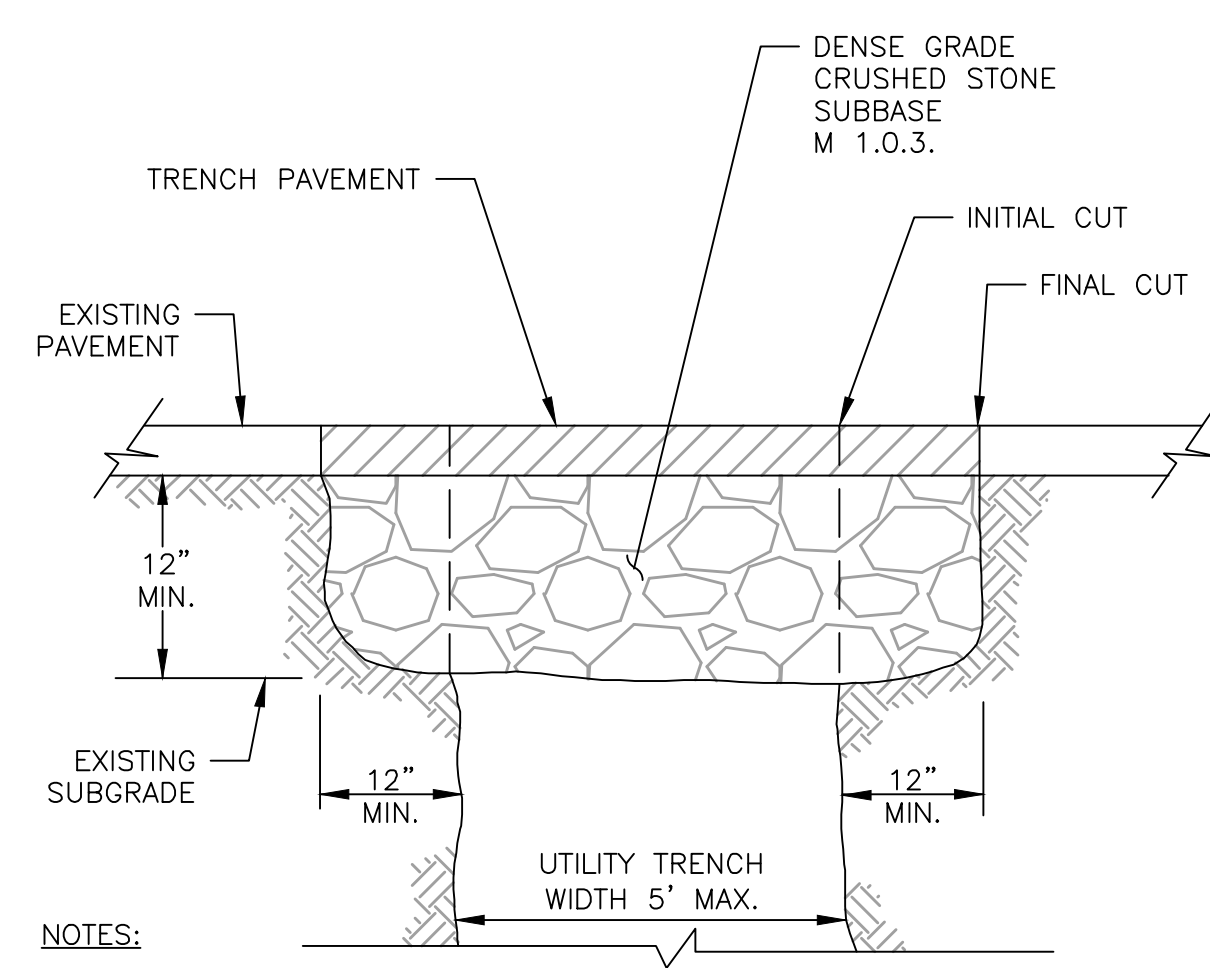

- NOTES:
1. TEMPORARY TRENCH PAVEMENT: 3" OF HOT MIX ASPHALT TO BE USED TO STABILIZE TRENCHES. TEMPORARY TRENCH PAVEMENT SHALL BE PLACED AT THE END OF EACH WORK DAY OR WEEK AS CALLED FOR IN THE CONTRACT SPECIFICATIONS. THE CONTRACTOR SHALL MAINTAIN THE TEMPORARY TRENCH PAVEMENT THROUGHOUT THE DURATION OF THE CONTRACT AT NO ADDITIONAL COST. THIS WORK SHALL BE INCLUDED IN THE UNIT PRICE FOR TEMPORARY TRENCH PAVEMENT.
 2. PERMANENT TRENCH PAVEMENT: 4.5" OF HOT MIX ASPHALT TO BE PLACED AND COMPACTED IN TWO SEPARATE LIFTS - 3" DENSE BINDER COURSE AND 1.5" TOP COURSE. IF THE EXISTING PAVEMENT IS GREATER THAN 4.5" IN DEPTH, THE CONTRACTOR SHALL MATCH THE EXISTING PAVEMENT DEPTH BY PLACING ADDITIONAL LIFTS OF DENSE BINDER AND THEN THE 1.5" TOP COURSE. THE MINIMUM THICKNESS OF PERMANENT TRENCH PATCH SHALL BE 4.5". PRIOR TO PLACING PAVEMENT, THE CONTRACTOR SHALL CUT THE TRENCH EDGE BACK A MINIMUM OF 12" AND COMPACT THE ROADWAY SUBBASE. THE CONTRACTOR SHALL MAINTAIN THE PERMANENT TRENCH PAVEMENT THROUGHOUT THE DURATION OF THE CONTRACT AT NO ADDITIONAL COST. THIS WORK SHALL BE INCLUDED IN THE UNIT PRICE FOR PERMANENT TRENCH PAVEMENT.
 3. ALL TRENCHES SHALL BE SAW CUT ONLY. NO OTHER METHOD OF CUTTING THE EXISTING PAVEMENT SHALL BE ACCEPTABLE. THIS WORK SHALL BE INCLUDED IN THE UNIT COST OF THE ASSOCIATED TRENCH PAVEMENT ITEM.
 4. ALL EDGES WHERE TRENCH PAVEMENT MEETS EXISTING PAVEMENT SHALL RECEIVE AN APPLICATION OF TACK COAT PRIOR TO PLACEMENT OF PAVEMENT. TACK COAT SHALL BE APPLIED BETWEEN EACH LIFT OF TRENCH PAVEMENT. ALL SEAMS SHALL BE SANDED AND SEALED AFTER THE PLACEMENT OF THE TOP COURSE PAVEMENT. THIS WORK SHALL BE INCLUDED IN THE UNIT COST OF THE ASSOCIATED TRENCH PAVEMENT ITEM.

TRENCH PAVEMENT DETAIL
N.T.S.

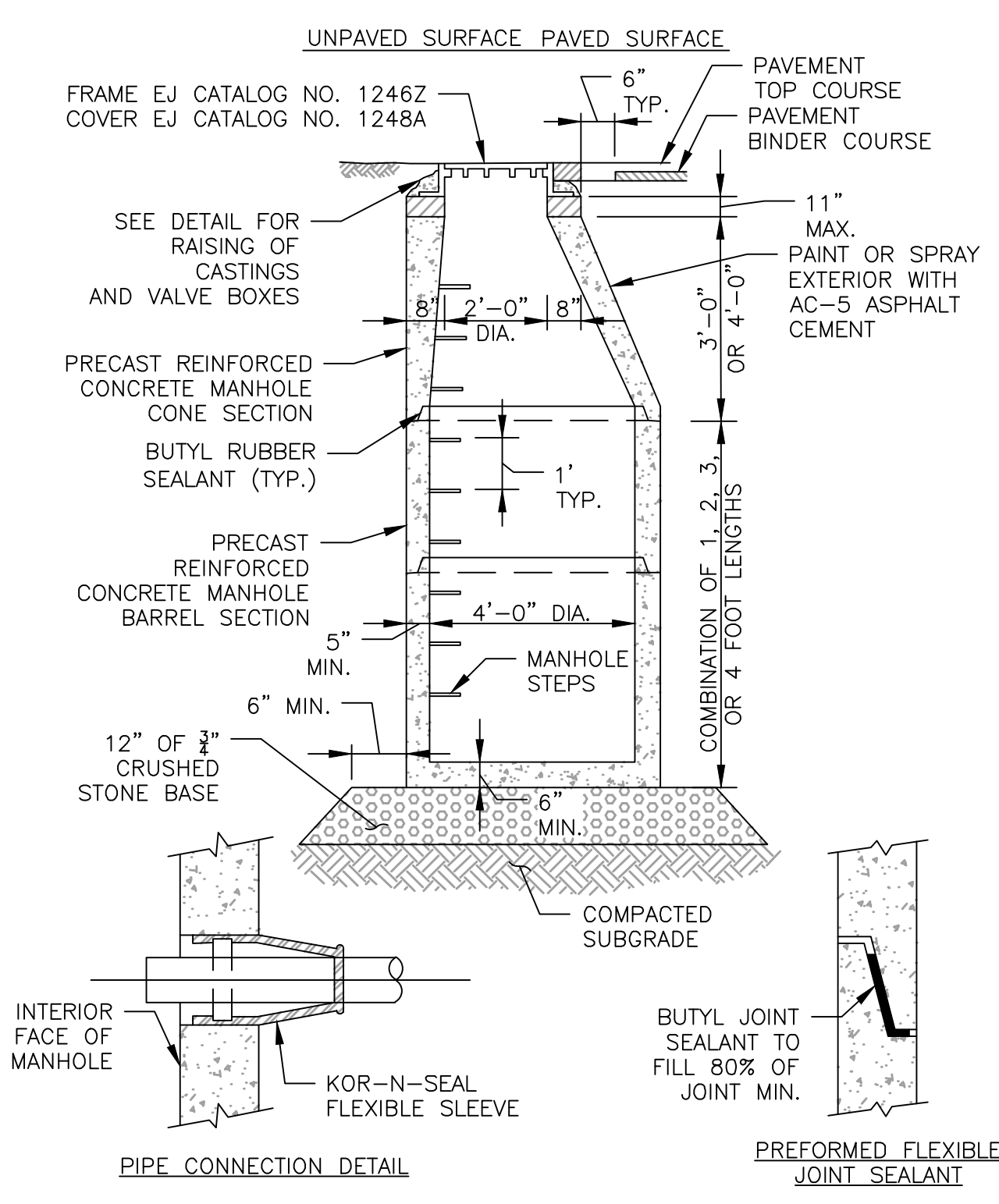

TYPICAL SEWER MANHOLE DETAIL
N.T.S.

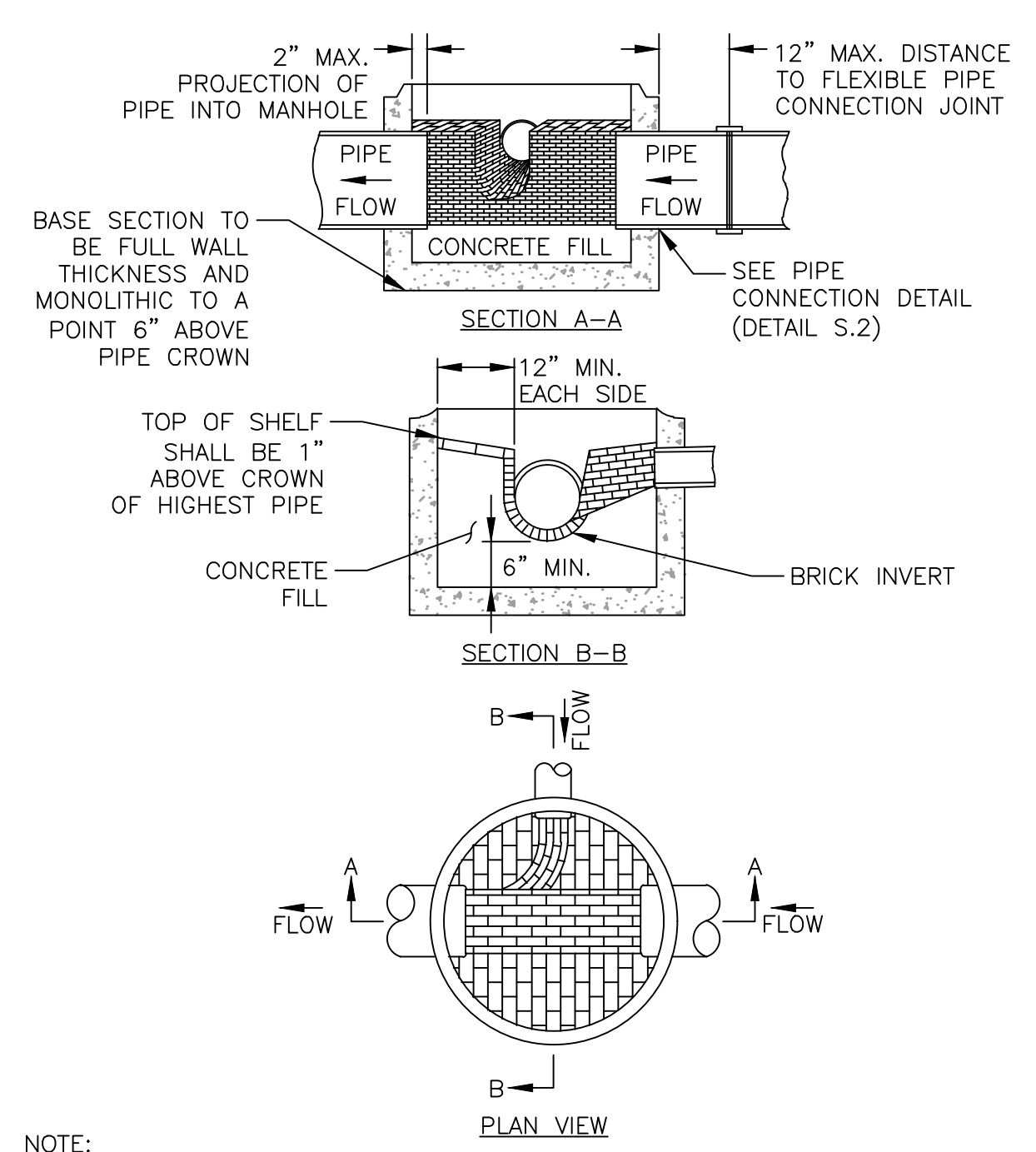

- NOTE:
1. CARE SHALL BE TAKEN TO INSURE THAT THE BRICK INVERT IS A SMOOTH CONTINUATION OF THE SEWER INVERT. INVERT BRICKS SHALL BE LAID ON EDGE.
 2. INVERT AND SHELF TO BE PLACED AFTER SUCCESSFUL VACUUM TEST.

TYPICAL SEWER INVERT DETAIL
N.T.S.

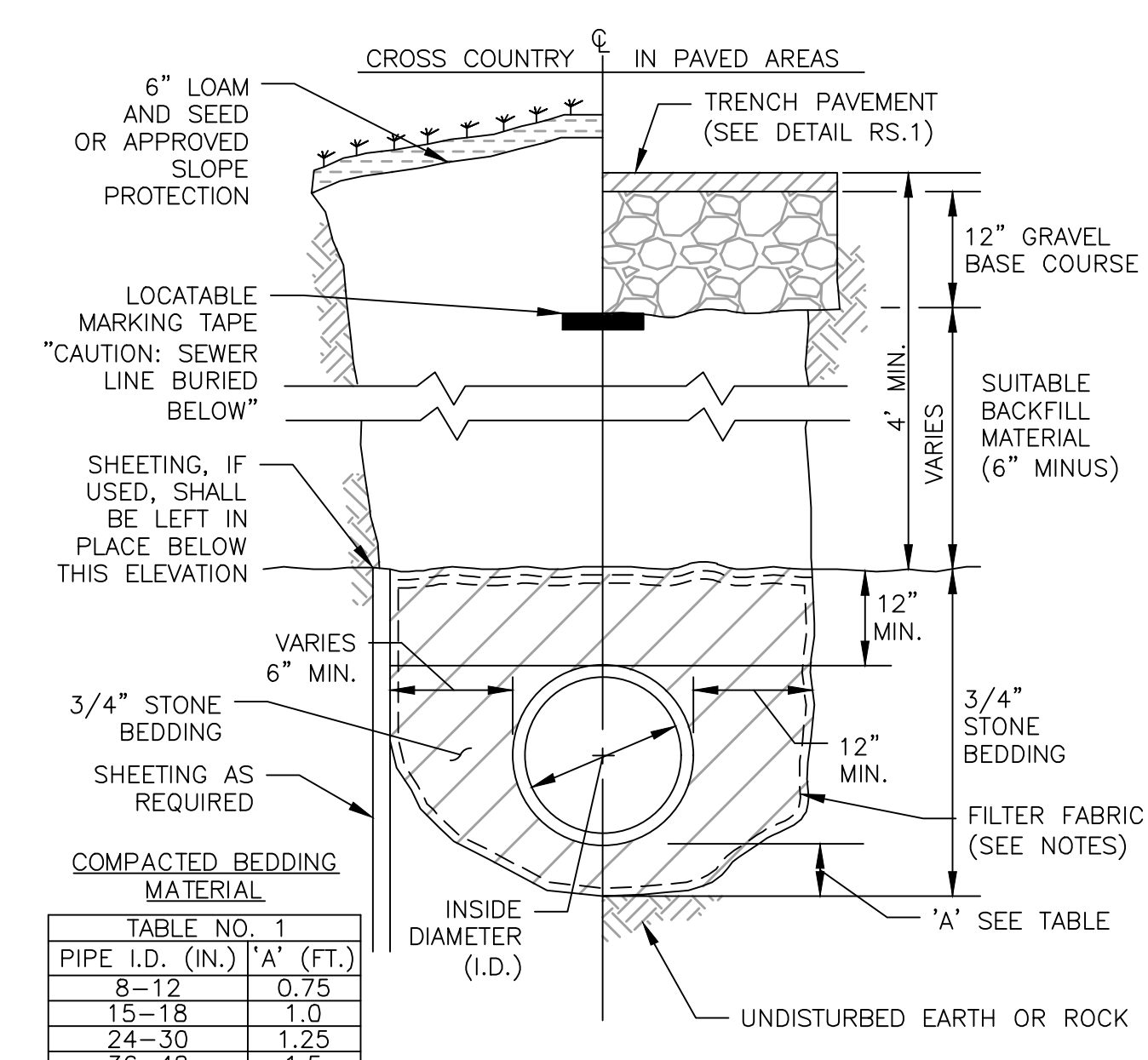
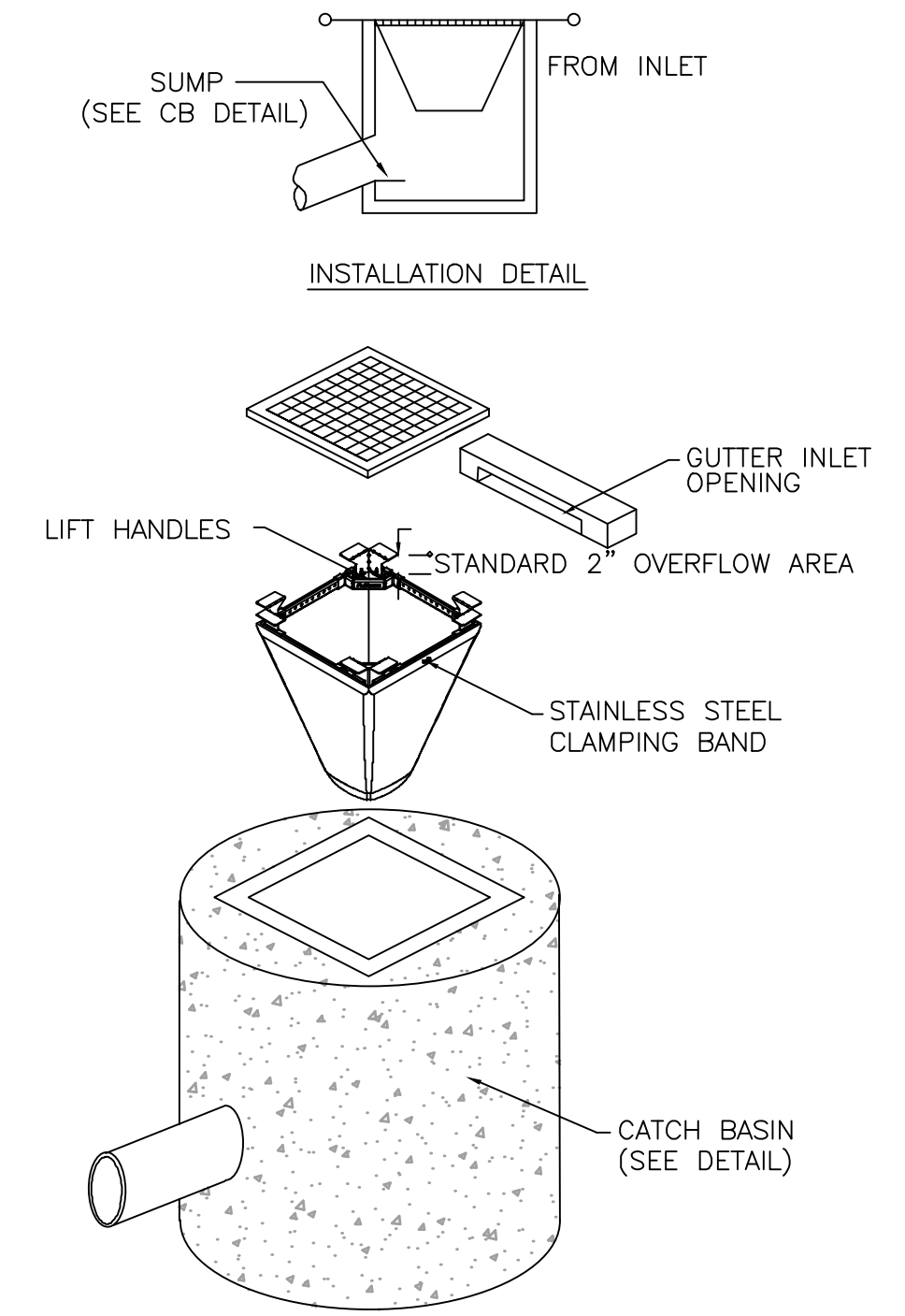

TABLE NO. 1
PIPE I.D. (IN.) 'A' (FT.)

8-12	0.75
15-18	1.0
24-30	1.25
36-48	1.5
48-72	2.0

TYPICAL SEWER TRENCH DETAIL
N.T.S.



- NOTE:
1. SILTSACKS SHALL BE FLEXSTORM CATCH-IT OR APPROVED EQUAL
 2. SILTSACKS SHALL BE INSTALLED IN ALL CATCH BASIN UNTIL DRAINAGE AREA HAS BEEN FULLY STABILIZED.

CATCH BASIN SILT SACK DETAIL
N.T.S.

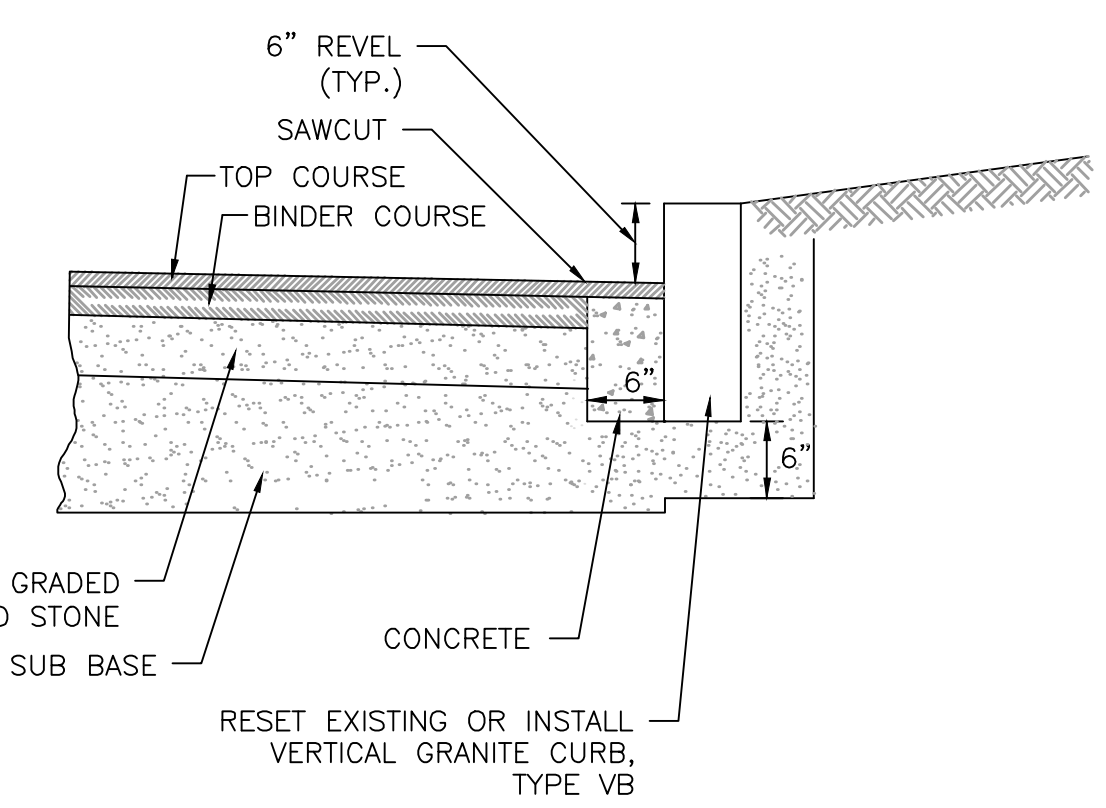

- NOTE:
1. CONTRACTOR SHALL REMOVE AND RESET EXISTING GRANITE CURBING AS REQUIRED. TO SALVAGE EXISTING GRANITE CURBING, THE CONTRACTOR SHALL CAREFULLY REMOVE, CLEAN AND STORE THE UNDAAGED CURB. ANY CURBING DAMAGED BY THE CONTRACTOR'S NEGLIGENCE SHALL BE REPLACED AT THE CONTRACTOR'S OWN EXPENSE.
 2. CONTRACTOR SHALL LOAM AND SEED ALL DISTURBED AREAS BEHIND RE-SET CURBING.

VERTICAL GRANITE CURBING
DETAIL
N.T.S.

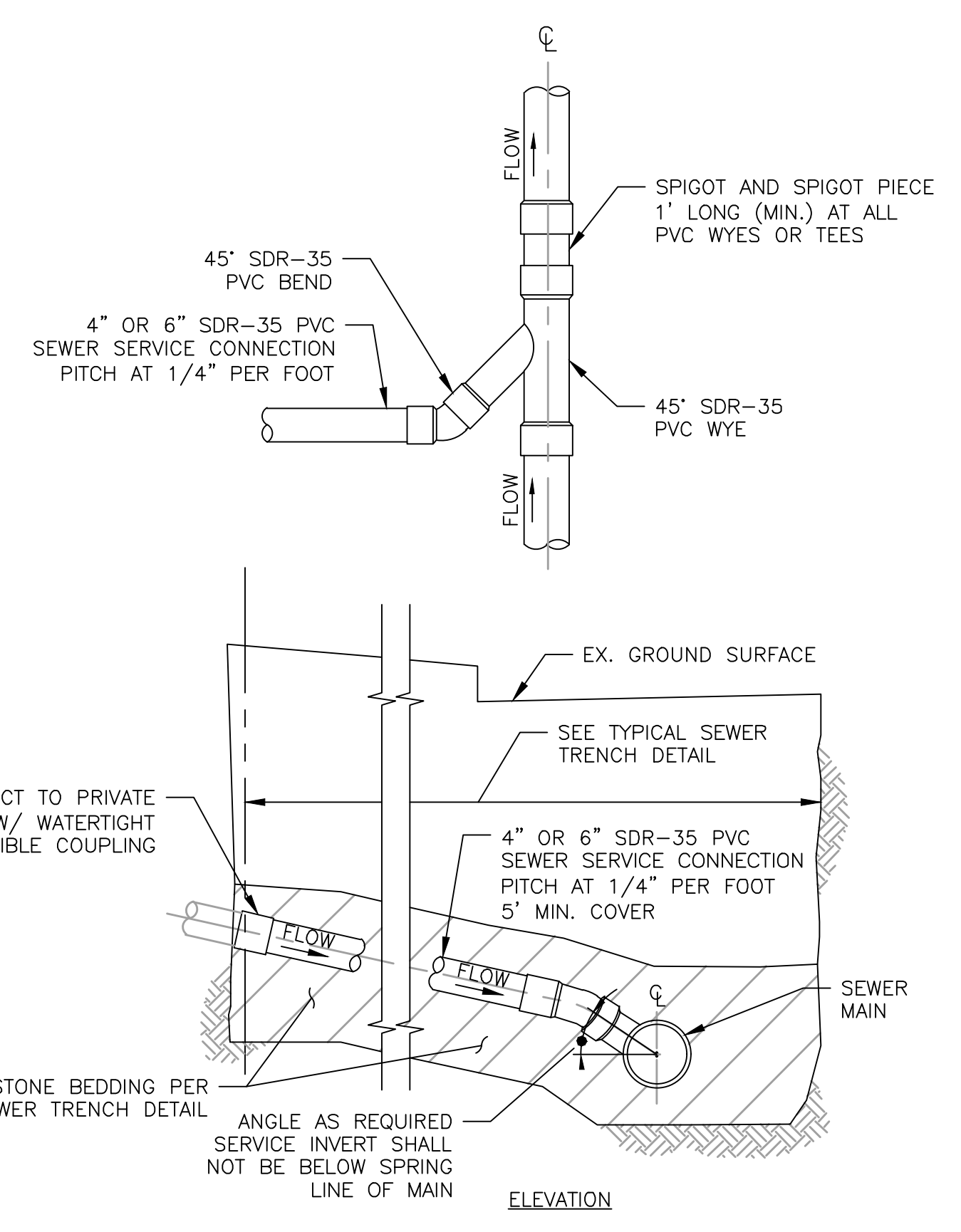

SEWER SERVICE DETAIL
N.T.S.

WATER MAIN DIAMETER	MAXIMUM TAP DIAMETER
6"	1"
8"	1"
10"	2"
12"	2"

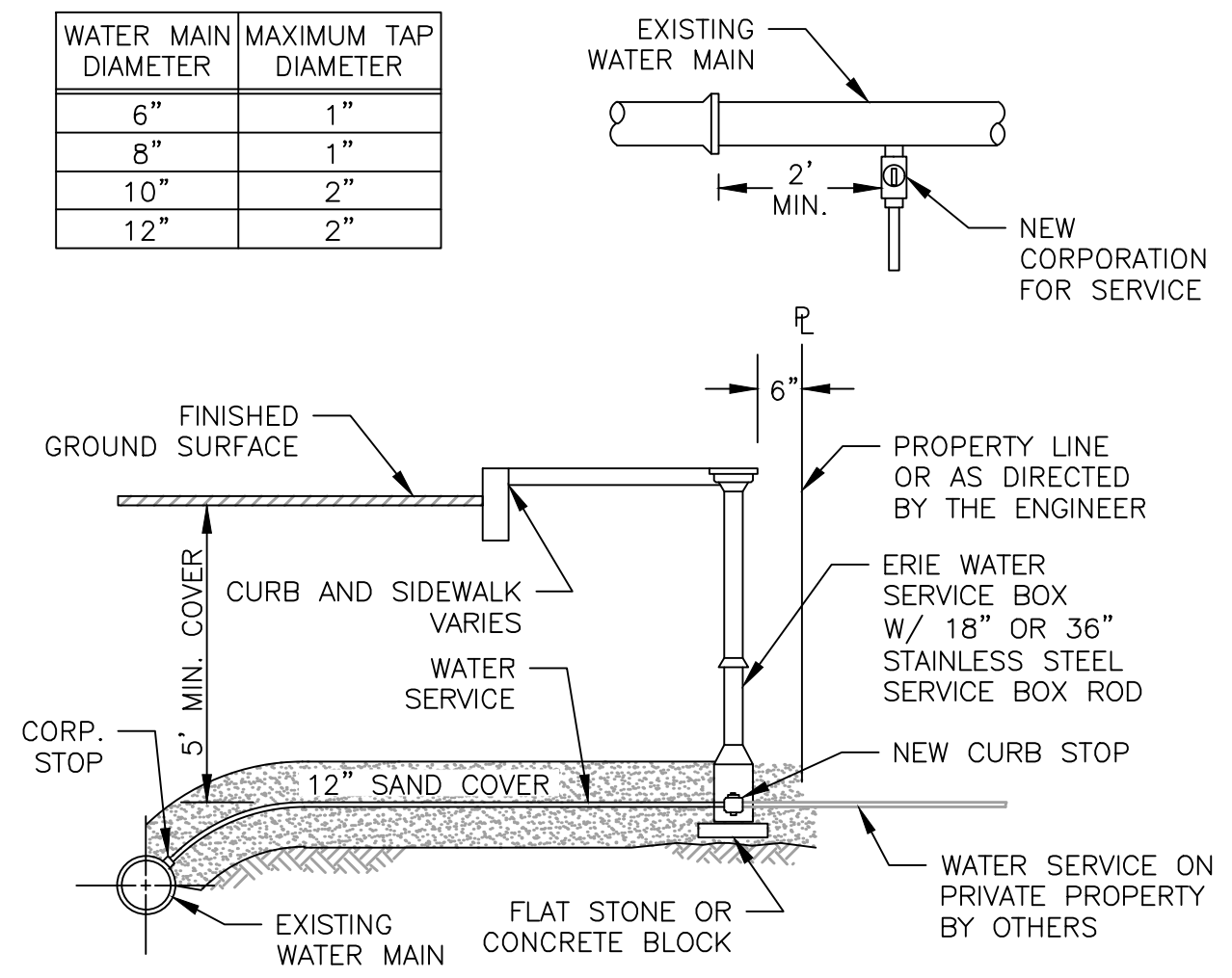

- NOTES:
1. ALL WATER SERVICES SHALL BE 1" DIA. TYPE K COPPER TUBING UNLESS OTHERWISE NOTED. SERVICE SHALL BE ONE CONTINUOUS LENGTH FROM MAIN TO CURB STOP.
 2. ALL WATER SERVICES SHALL BE REPLACED UP TO THE RIGHT OF WAY.
 3. WHERE THE SIZE OF THE CONNECTION EXCEEDS THAT GIVEN IN THE TABLE, THE CONNECTION SHALL BE MADE MEANS OF A TAPPED SADDLE OR TEE CONNECTION.
 4. WHERE GATE BOX IS NEAR OBSTRUCTION SUCH AS FENCE OR WALL, PLACE TO ALLOW SUFFICIENT ROOM TO OPERATE VALVE WITH WRENCH.
 5. NEW TAPPED CONNECTIONS SHALL NOT BE ALLOWED CLOSER THAN 2' FROM A BELL JOINT ON THE EXISTING WATER MAIN.
 6. INSULATION TO BE USED AS REQUIRED BY THE WATER & SEWER SUPERINTENDENT.

TYPICAL WATER SERVICE DETAIL
N.T.S.

DATE:	REVISION DATE:	DRAWN BY:	DESIGNED BY:	REVIEWED BY:	APPROVED BY:
10/28/20		IAM	IAM	IAM	MCC
SCALE:					
FILE:					
SHEET:					

TRAFFIC MANAGEMENT NOTES:

GENERAL:

- ALL TEMPORARY TRAFFIC CONTROL WORK SHALL CONFORM TO THE LATEST EDITION OF THE "MANUAL ON UNIFORM TRAFFIC CONTROL DEVICES" (MUTCD) AND THE MHD STANDARD DETAILS AND DRAWINGS FOR THE DEVELOPMENT OF TRAFFIC MANAGEMENT PLANS.
- THE TRAFFIC MANAGEMENT PLANS CONTAINED HEREIN ARE GIVEN AS A GUIDE FOR TYPICAL WORK ZONE TRAFFIC CONTROL APPLICATIONS FOR THE TYPES OF WORK ANTICIPATED FOR THIS PROJECT. THEY ARE NOT INTENDED TO COVER ALL POSSIBLE CONSTRUCTION OPERATIONS WHICH THE CONTRACTOR MAY CHOOSE TO EMPLOY. WORK ZONE TRAFFIC CONTROL FOR OTHER CONSTRUCTION OPERATIONS OR OTHER TRAFFIC SITUATIONS IF APPLICABLE SHALL BE IN ACCORDANCE WITH THE M.U.T.C.D. AND AS APPROVED OR REQUIRED BY THE CITY. THE CONTRACTOR SHALL SUBMIT ALTERNATE TRAFFIC CONTROL PLANS FOR APPROVAL WHEN NECESSARY.
- WORK WITHIN THE TRAVELED WAY SHALL BE DETERMINED DURING THE PRE-CONSTRUCTION MEETING. TEMPORARY CONSTRUCTION SIGNING AND ALL OTHER TRAFFIC CONTROL DEVICES SHALL BE IN PLACE PRIOR TO THE START OF ANY WORK.
- TEMPORARY CONSTRUCTION SIGNING, BARRICADES AND ALL OTHER NECESSARY WORK ZONE TRAFFIC CONTROL DEVICES SHALL BE REMOVED FROM THE HIGHWAY OR COVERED WHEN THEY ARE NOT REQUIRED FOR CONTROL OF TRAFFIC.
- SIGNS AND SIGN SUPPORTS LOCATED ON OR NEAR THE TRAVELED WAY, AND REFLECTORIZED PLASTIC DRUMS WITH LIGHTING DEVICES MOUNTED ON THEM, MUST PASS THE CRITERIA SET FORTH IN NCHRP REPORT 350, "RECOMMENDED PROCEDURES FOR THE SAFETY PERFORMANCE EVALUATION OF HIGHWAY FEATURES."
- CONTRACTOR SHALL MAINTAIN ABUTTER ACCESS AT ALL TIMES EXCEPT FOR VERY SHORT PERIODS APPROVED BY THE TOWN. CONTRACTORS SHALL NOTIFY EACH ABUTTER AT LEAST 24 HOURS IN ADVANCE OF THE START OF ANY WORK THAT WILL REQUIRE THE TEMPORARY CLOSURE OF ACCESS, SUCH AS CONDUIT INSTALLATION, EXISTING PAVEMENT EXCAVATION, TEMPORARY DRIVEWAY PAVEMENT PLACEMENT AND SIMILAR OPERATIONS.
- THE FIRST THREE PLASTIC DRUMS OF A TAPER MAY BE MOUNTED WITH TYPE A LIGHTS.
- THE ADVISORY SPEED LIMIT, IF REQUIRED, SHALL BE AS SHOWN ON THESE PLANS OR AS DETERMINED BY THE ENGINEER.
- DISTANCES ARE A GUIDE AND MAY BE ADJUSTED IN THE FIELD BY THE ENGINEER.
- MAXIMUM SPACING OF TRAFFIC DEVICES IN A TAPER (DRUMS OR CONES) IS EQUAL IN FEET TO THE SPEED LIMIT IN MPH.
- MINIMUM LANE WIDTH IS TO BE 11 FEET UNLESS OTHERWISE SHOWN. MINIMUM LANE WIDTH TO BE MEASURED FROM THE EDGE OF DRUMS OR MEDIAN BARRIER. ONE (1) THROUGH TRAVEL LANE HAVING A MINIMUM WIDTH OF 11 FEET MAY BE PROVIDED FOR BOTH DIRECTIONS (LANE TO BE SHARED AND DIRECTION OF TRAVEL TO ALTERNATE IN SOME SITUATIONS UNDER POLICE CONTROL) EXCEPT WHERE ROAD CLOSURE IS SHOWN ON THE DRAWINGS OR OTHERWISE PERMITTED BY ENGINEER.
- LANE RESTRICTIONS MAY NOT REMAIN DURING NON-WORKING HOURS. AFTER EACH WORKING DAY, TRAFFIC CONTROL DEVICES THAT ARE NOT REQUIRED SHALL BE MOVED OFF THE ROADWAY OR FULL DEPTH CONSTRUCTION AREA AND PLACED SO AS NOT TO IMPEDE PEDESTRIAN AREAS, ABUTTER ACCESS OR CAUSE CONFUSION TO MOTORISTS.
- ALL SIGNS SHALL BE MOUNTED ON THEIR OWN STANDARD SIGN SUPPORTS.
- IF APPROVED BY OWNER & AGENCY WITH JURISDICTION, NIGHT WORK OPERATIONS SHALL INCLUDE PROPERLY LIT & PLACED LUMINAIRES MEETING THE REQUIREMENTS OF THE MUTCD AND MASSDOT.
- ALL TRAFFIC MANAGEMENT SETUPS SHOULD ACCOMMODATE LARGE VEHICLES (WB-50) UNLESS A TRUCK EXCLUSION IS PRESENT.
- ALL WORK ZONE AREAS SHOULD BE PROTECTED APPROPRIATELY. ALL EXPOSED WORK ZONES SHOULD BE STEEL PLATED OR BACK FILLED WHEN NO WORK IS UNDERWAY/PERFORMED AND APPROPRIATELY SIGNED.

GRADE DIFFERENCES:

- WHERE THERE IS A LONGITUDINAL DIFFERENCE IN ELEVATION BETWEEN THE EXISTING PAVEMENT AND COLD PLANED OR NEW PAVEMENT, THE CONTRACTOR SHALL PATCH A TEMPORARY HOT MIX ASPHALT WEDGE WITH A 12:1 (OR FLATTER) SLOPE FOR SMOOTH TRANSITION. SEE DETAIL, THIS SHEET.
- CROSS-SECTIONAL GRADE DIFFERENCES IN EXCESS OF 2" DURING NON-WORKING HOURS WILL REQUIRE DELINEATION BY USE OF REFLECTORIZED DRUMS.
- CROSS-SECTIONAL GRADE DIFFERENCES IN EXCESS OF 4" DURING NON-WORKING HOURS SHALL BE PROTECTED BY BACKFILLING WITH A WEDGE OF EARTHWORK TO BE COMPACTED AT 4:1 SLOPE AND WILL ALSO REQUIRE DELINEATION BY USE OF DRUMS.
- A MINIMUM SLOPE OF 4:1 MUST BE MAINTAINED AFTER WORKING HOURS DURING SUBBASE AND BASE COURSE INSTALLATION ALONG EDGE OF THE TRAVELWAY (SEE DETAIL, NEXT SHEET). A MINIMUM SLOPE OF 8:1 MUST BE MAINTAINED ON ALL ABUTTED ACCESS DRIVES AND A MINIMUM SLOPE OF 12:1 MUST BE MAINTAINED ON ALL SIDEWALKS.

CONSTRUCTION SIGNING:

- THE FIRST CONSTRUCTION SIGN IN A SERIES ON EACH APPROACH TO THE PROJECT SHALL BE FLUORESCENT ORANGE, HIGH PERFORMANCE (OR HIGH DENSITY) SHEETING.
- ALL CONSTRUCTION SIGNS SHALL BE BLACK LEGEND ON A REFLECTORIZED ORANGE BACKGROUND UNLESS OTHERWISE NOTED AND SHALL CONFORM TO THE MUTCD.
- EXISTING GUIDE SIGNS SHALL BE TEMPORARILY RESET AS REQUIRED BY THE TOWN.
- ALL SIGNS, INCLUDING EXISTING, THAT ARE NOT REPRESENTATIVE OF ACTUAL WORK CONDITIONS SHALL BE EITHER COVERED OR REMOVED WHEN NOT APPLICABLE.
- IF USED, W20-4 AND W20-5 SIGNS SHALL BE TAKEN DOWN OR COVERED AT THE CLOSE OF EACH DAY. LANE RESTRICTIONS ARE PERMITTED TO REMAIN OVERNIGHT IN ACCORDANCE WITH NOTE ABOVE.
- USE W20-8 SIGNS ONLY WHILE POLICE ARE DIRECTING TRAFFIC. THEY SHALL BE TAKEN DOWN OR COVERED AT THE CLOSE OF EACH WORK DAY.
- SIGNS MUST BE PROFESSIONALLY LETTERED. NO HANDWRITTEN/PAINTED SIGNS SHALL BE ALLOWED.
- WHERE LANE SHIFTS, WORK ZONES, OR OTHER CONSTRUCTION ACTIVITIES INFRINGE UPON ON-STREET PARKING AREAS, THE CONTRACTOR SHALL INSTALL TEMPORARY 'NO PARKING/TOW AWAY ZONE' SIGNS (R8-3/R7-201) AS APPROPRIATE AT LEAST 24 HOURS IN ADVANCE. THE R8-3/R7-201 SIGNS SHALL BE TAKEN DOWN OR COVERED AT THE CLOSE OF EACH DAY UNLESS PARKING RESTRICTIONS ARE PERMITTED TO REMAIN OVERNIGHT AS REQUIRED BY THE TOWN.

PAVEMENT MARKINGS:

- PAVEMENT MARKINGS WHICH ARE NO LONGER APPLICABLE SHALL BE REMOVED. APPLY TEMPORARY MARKINGS WHERE SHOWN ON THE TRAFFIC MANAGEMENT PLANS AND AS REQUIRED BY THE TOWN.
- ON PROJECTS WHERE PAVEMENT OVERLAY IS NOT DESIGNATED, EXISTING PAVEMENT MARKINGS WHICH ARE IN CONFLICT WITH TEMPORARY TRAFFIC CONTROLS SHOULD BE COVERED TEMPORARILY WITH BLACKOUT TAPE, AS REQUIRED BY THE TOWN. FOR THE FULL DURATION OF THE PHASE IN PROGRESS, TEMPORARY PAINTED OR REMOVABLE TAPE MARKINGS SHALL BE USED AS NECESSARY FOR ALL PHASES OF CONSTRUCTION.

FORMULAS FOR DETERMINING TAPER LENGTHS

Speed Limit (S)	Taper Length (L) Feet
40 MPH OR LESS	$L = \frac{WS^2}{60}$
45 MPH OR MORE	$L = WS$

WHERE: L = TAPER LENGTH IN FEET (METERS)

W = WIDTH OF OFFSET IN FEET (METERS)

S = POSTED SPEED LIMIT, OR OFF-PEAK 85TH-PERCENTILE SPEED PRIOR TO

WORK STARTING, OR THE ANTICIPATED OPERATING SPEED IN MPH (KM/H)

Source: Table 6C-4 2003 MUTCD

SIGN LEGEND:

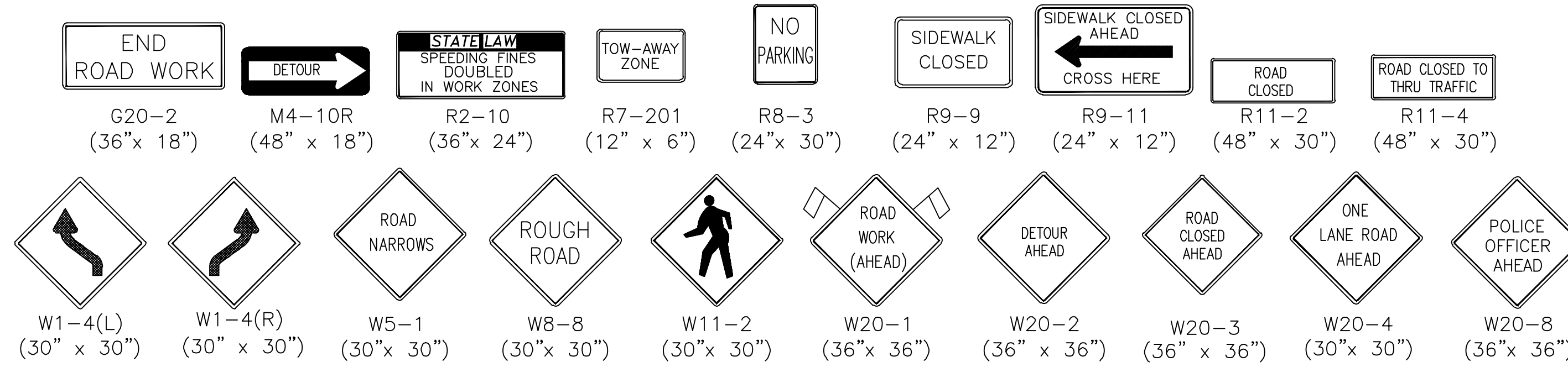

LEGEND:

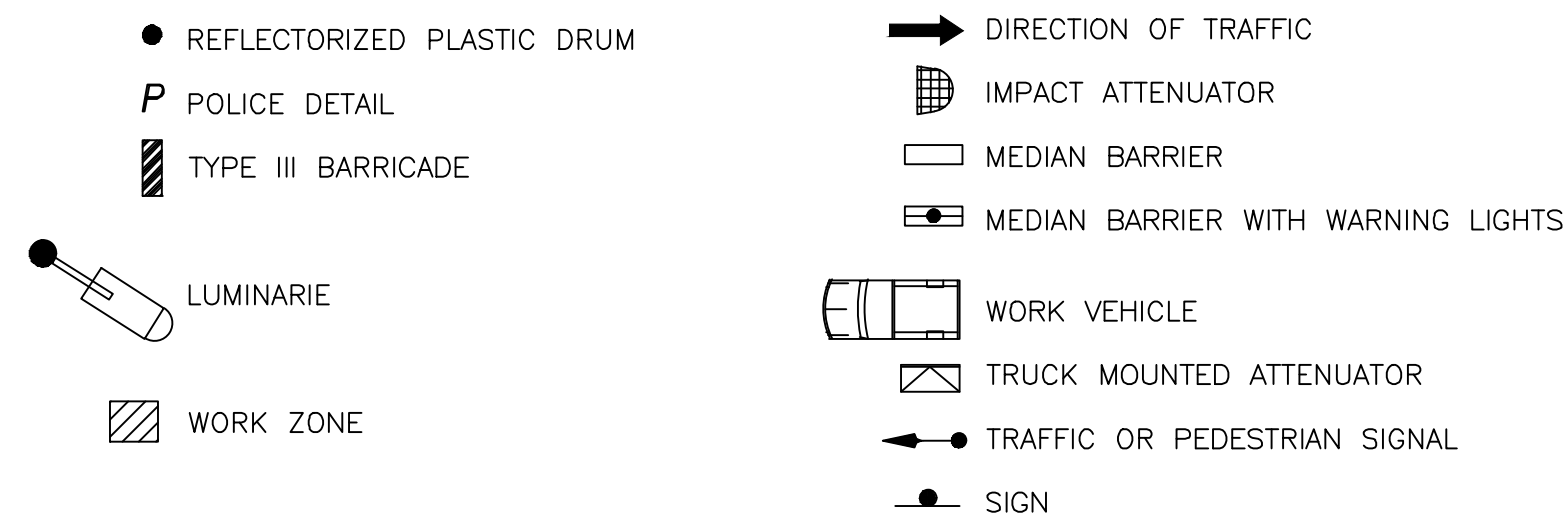

TAPER LENGTH CRITERIA FOR TEMPORARY TRAFFIC CONTROL ZONES

Type of Taper	Taper Length (L)*
MERGING TAPER	AT LEAST L
SHIFTING TAPER	AT LEAST 0.5L
SHOULDER TAPER	AT LEAST 0.33L
ONE-LANE, TWO-WAY TRAFFIC TAPER	100 FT MAXIMUM
DOWNSTREAM TAPER	100 FT PER LANE

Source: Table 6C-3 2003 MUTCD

SUGGESTED WORK ZONE WARNING SIGN SPACING

Road Type	Distance Between Signs**		
	A	B	C
LOCAL OR LOW VOLUME ROADWAYS*	350	350	350
MOST OTHER ROADWAYS*	500	500	500
FREEWAYS AND EXPRESSWAYS*	1,000	1,500	2,640

* SPEED CATEGORY TO BE DETERMINED BY MASSDOT.

** DISTANCES ARE SHOWN IN FEET. THE COLUMN HEADINGS A, B, AND C ARE THE DIMENSIONS SHOWN IN THE DETAIL/ TYPICAL SETUP FIGURES. THE A DIMENSION IS THE DISTANCE FROM THE TRANSITION OR POINT OF RESTRICTION TO THE FIRST SIGN. THE B DIMENSION IS THE DISTANCE BETWEEN THE FIRST AND SECOND SIGNS. THE C DIMENSION IS THE DISTANCE BETWEEN THE SECOND AND THIRD SIGNS. (THE "THIRD" SIGN IS THE FIRST ONE TYPICALLY ENCOUNTERED BY A DRIVER APPROACHING A TEMPORARY TRAFFIC CONTROL (TTC) ZONE.)

THE "THIRD" SIGN ABOVE IS REFERRED TO AS THE INITIAL ADVANCE WARNING SIGN ON THE IMP SETUPS. IT IS THE ONE WHICH MAY OFTEN HAVE THE "STANDARD RED OR RED-ORANGE FLAGS (16 in. X 16 in.)" MOUNTED ON IT. THESE INITIAL ADVANCE WARNING SIGNS ARE LOCATED AT THE PROJECT LIMITS ON ALL APPROACHES (I.E. THE W20-1 SERIES (ROAD WORK XX FT) SIGNS), AND USUALLY REMAIN FOR THE DURATION OF THE PROJECT.

THE FIRST AND SECOND WARNING SIGNS ABOVE ARE REFERRED TO AS THE OPERATIONAL (DAY-TO-DAY) WORK ZONE SIGNS AND MAY BE MOVED DEPENDING ON WHERE THE SPECIFIC ROADWAY WORK FOR THAT DAY IS LOCATED.

R2-10 SIGNS SHALL BE PLACED BETWEEN THE SECOND AND THIRD SIGNS.

R2-10, W20-1 AND G20-2 SERIES SIGNS ARE TO BE INCLUDED ON ALL DETAILS/TYPICAL SETUPS.

STOPPING SIGHT DISTANCE AS A FUNCTION OF SPEED

SPEED* (mph)	DISTANCE (ft)
20	115
25	155
30	200
35	250
40	305
45	360
50	425
55	495
60	570
65	645
70	730
75	820

*POSTED SPEED, OFF-PEAK 85TH-PERCENTILE SPEED PRIOR TO WORK STARTING, OR THE ANTICIPATED OPERATING SPEED

THESE VALUES MAY BE USED TO DETERMINE THE LENGTH OF LONGITUDINAL BUFFER SPACES.

THE DISTANCES IN THE ABOVE CHART REPRESENT THE MINIMAL VALUES FOR BUFFER SPACING.

Source: Table 6C-2 2003 MUTCD

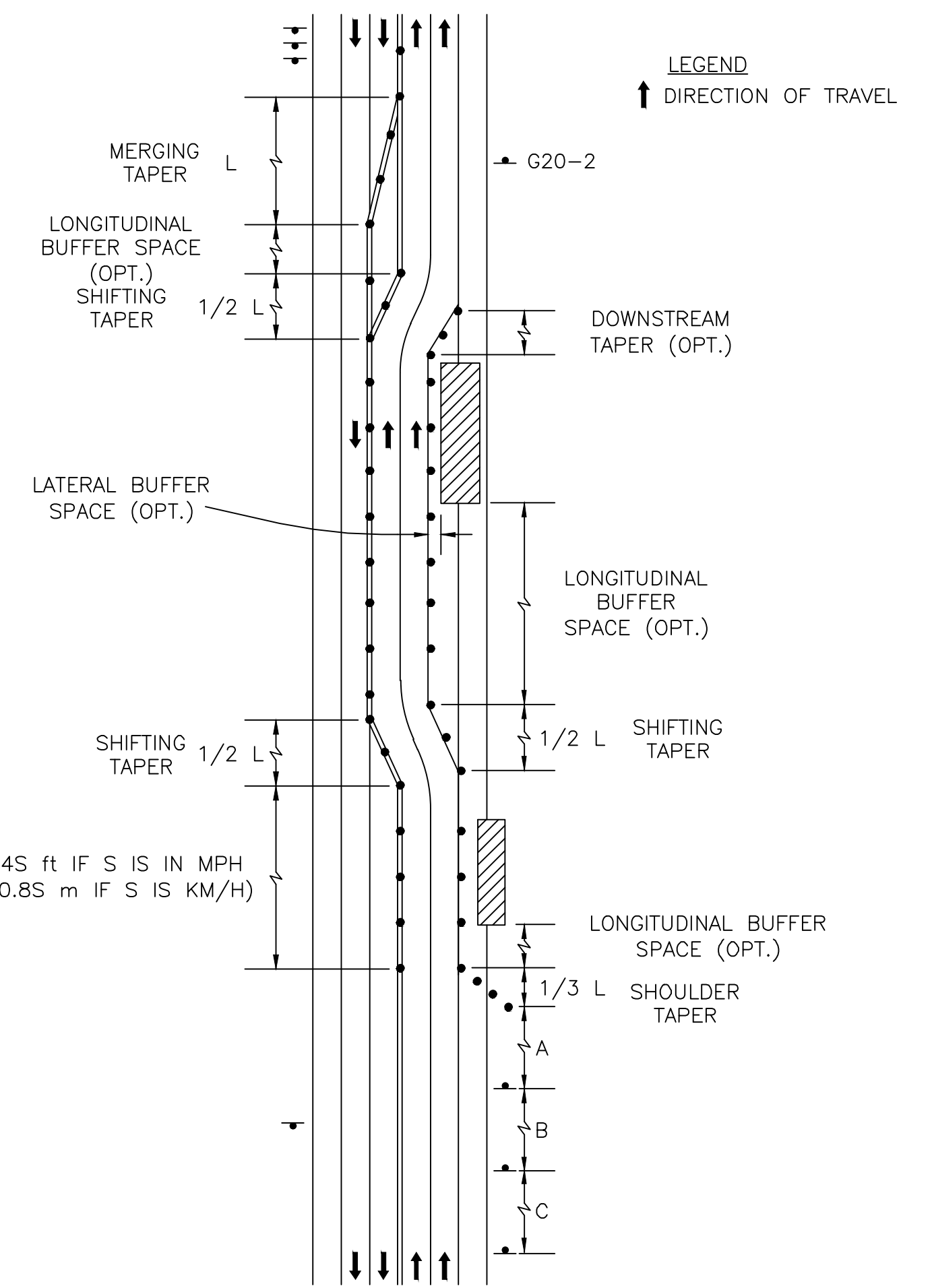

TYPES OF TAPERS AND BUFFER SPACES

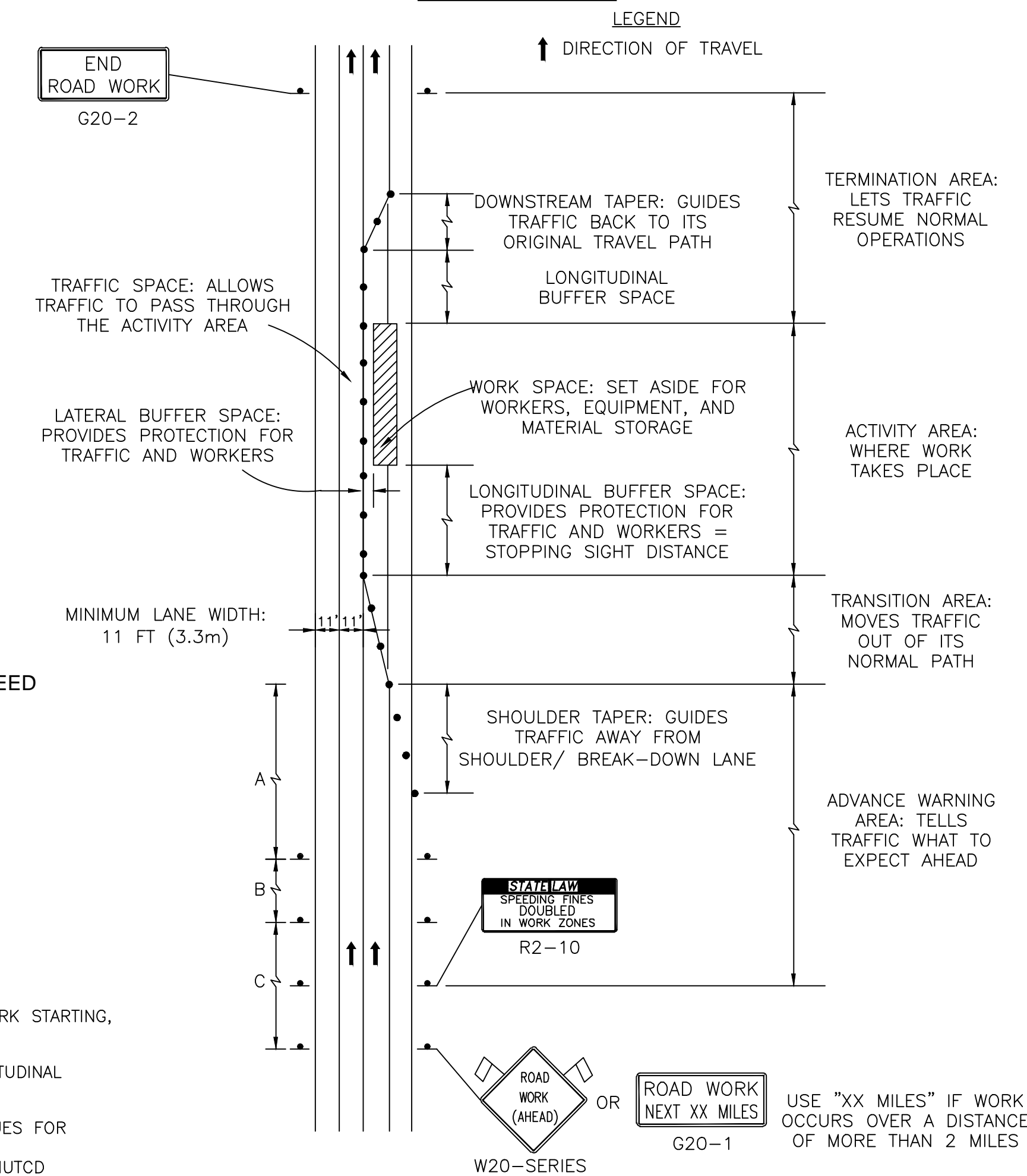

COMPONENT PARTS OF A TEMPORARY TRAFFIC CONTROL ZONE

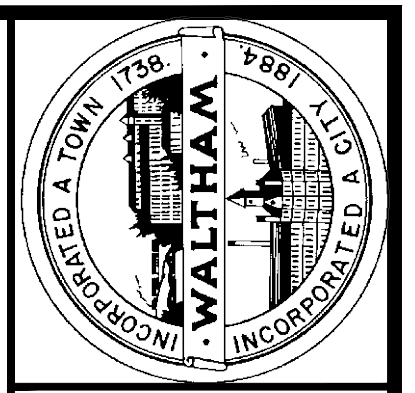

CITY OF WALTHAM ENGINEERING DEPARTMENT
KENMORE TERRACE
 SEWER MAIN REPLACEMENT

REVISION DATE:	DRAWN BY:	DESIGNED BY:	REVIEWED BY:	APPROVED BY:
	IAM	IAM	IAM	MCC

DATE: 10/28/20
 SCALE: N.T.S.
 FILE: KENMORETSEWER
SHEET 6 OF 7

ATTACHMENT C

KENMORE TERRACE

SCALES: 40 FT. HOR. & 4 FT. VERT. PER IN.

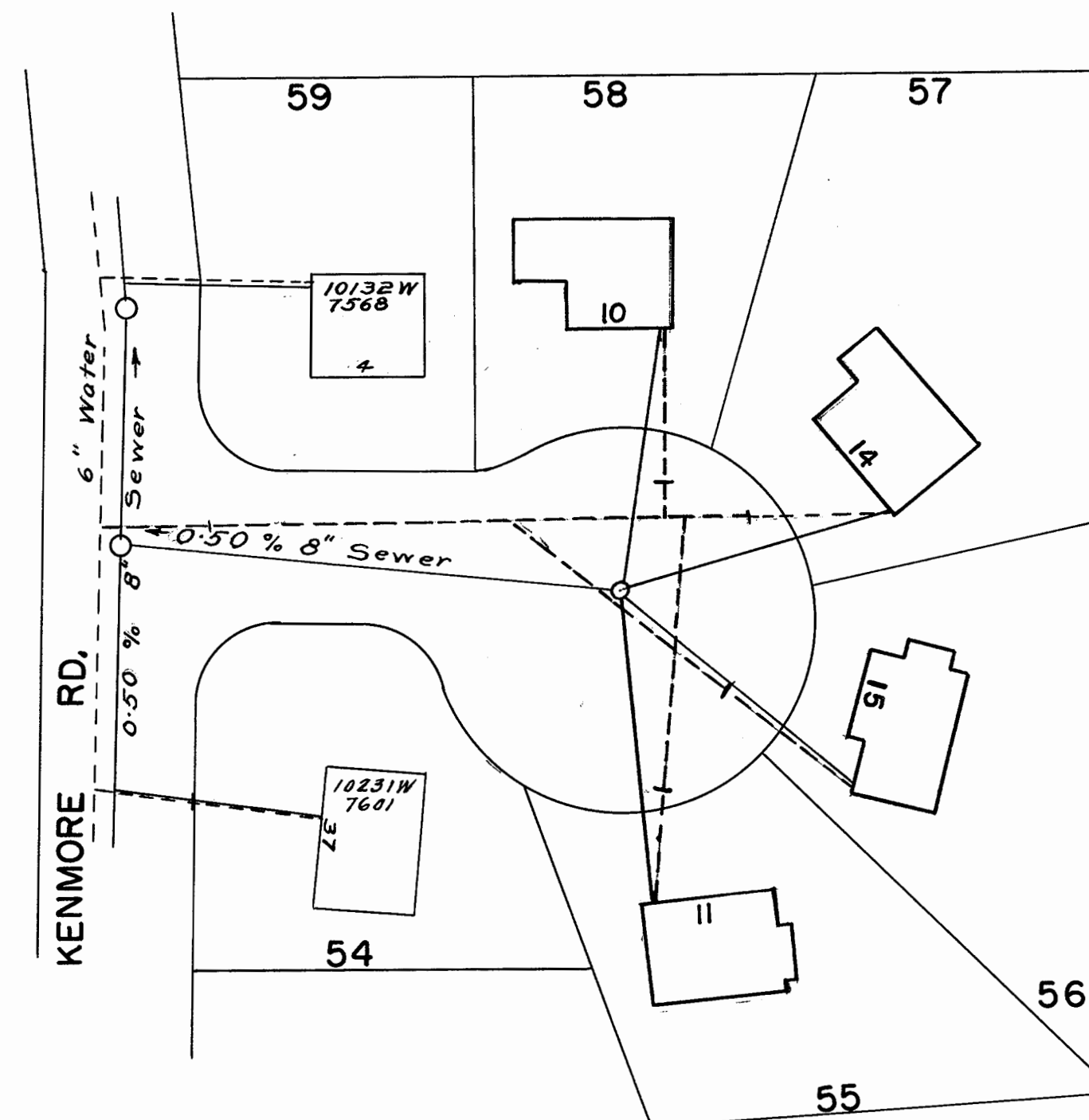
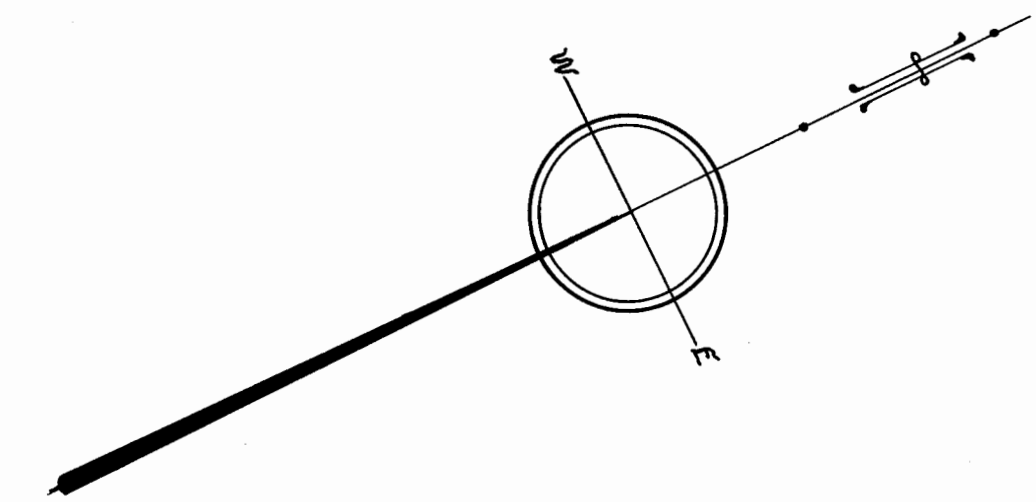
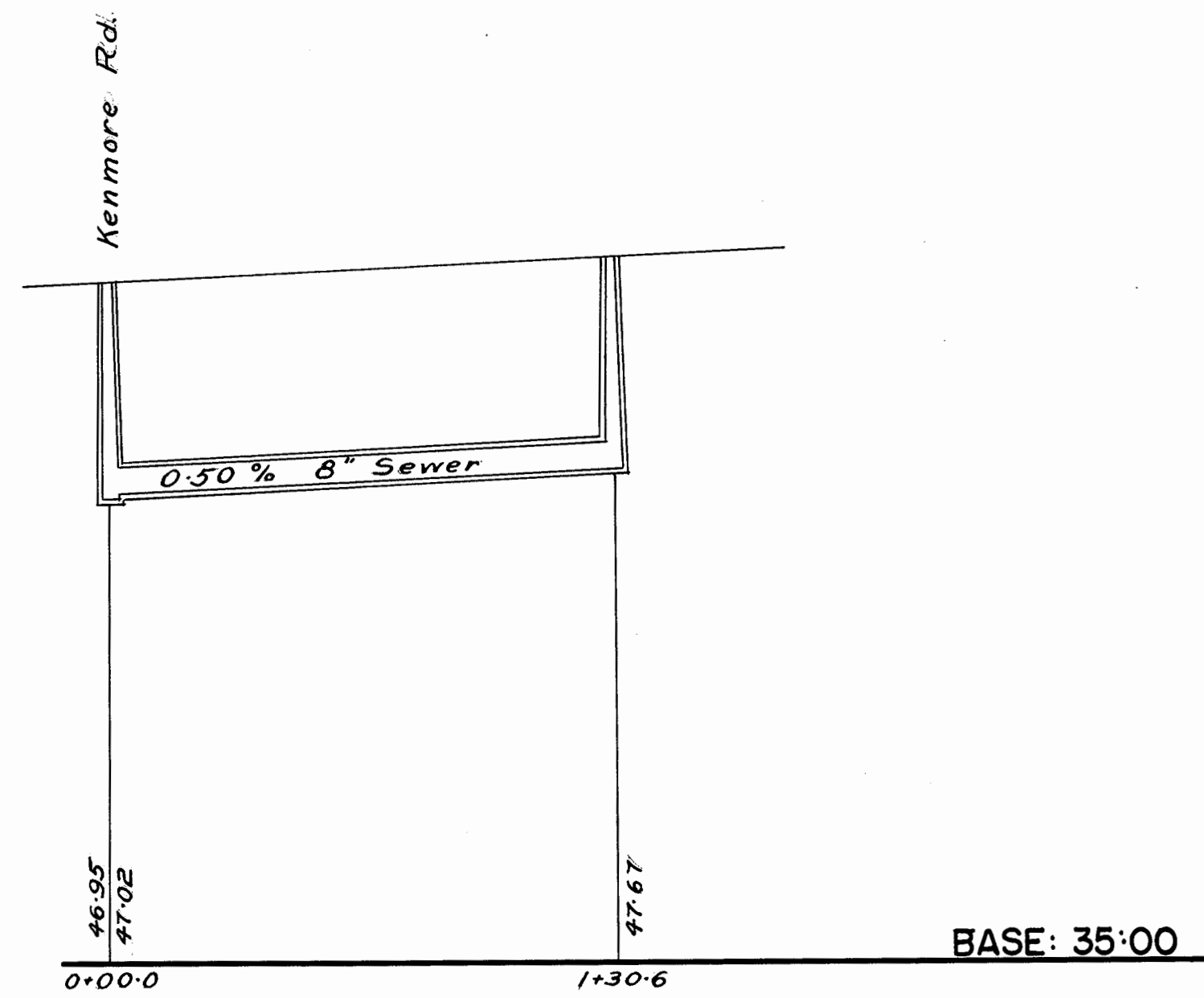

J.E.S.

KENMORE ROAD

SCALES: 40 FT. HOR. & 4 FT. VERT. PER IN

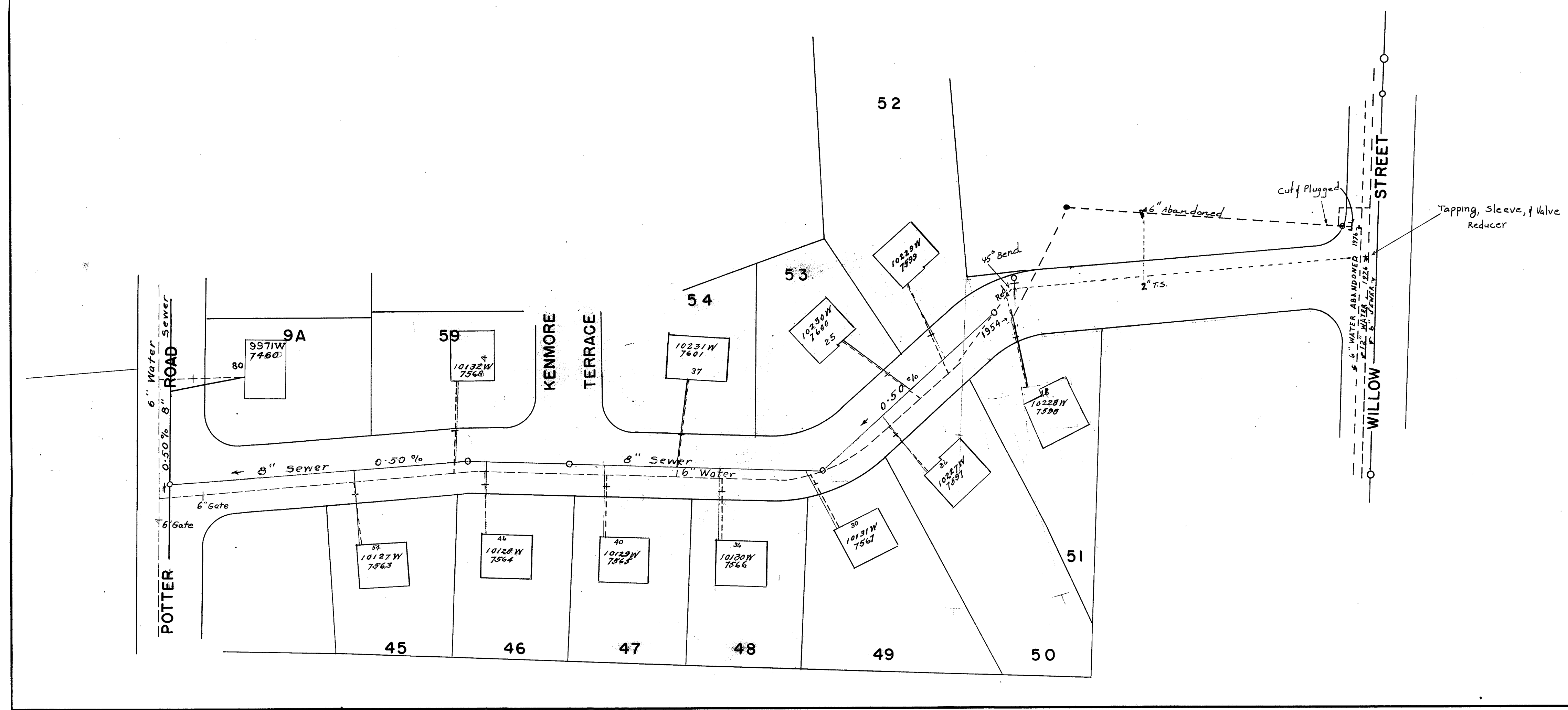
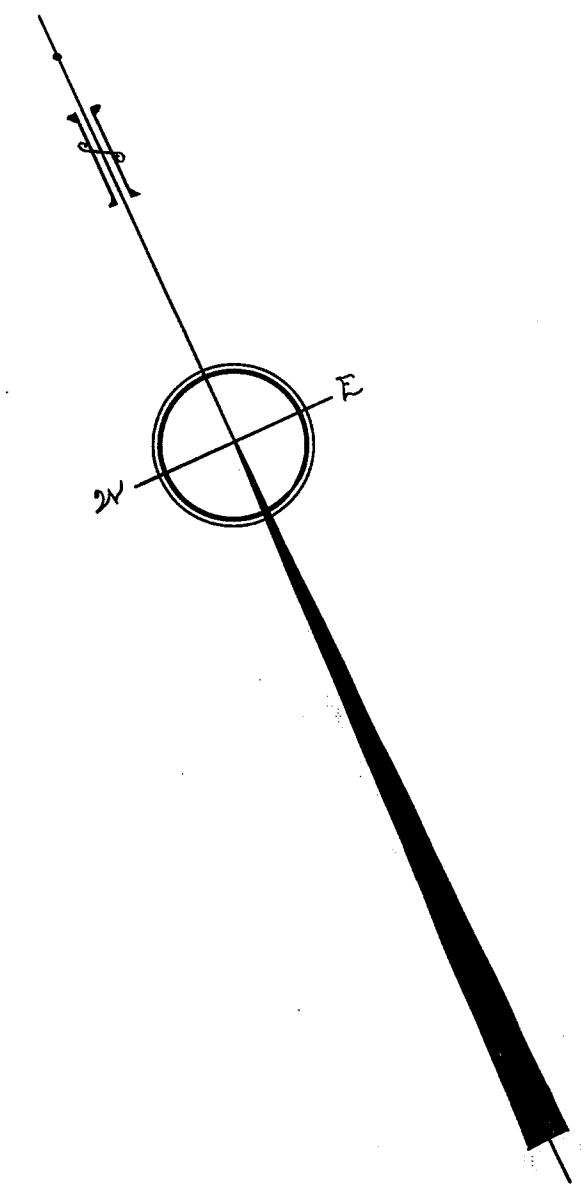
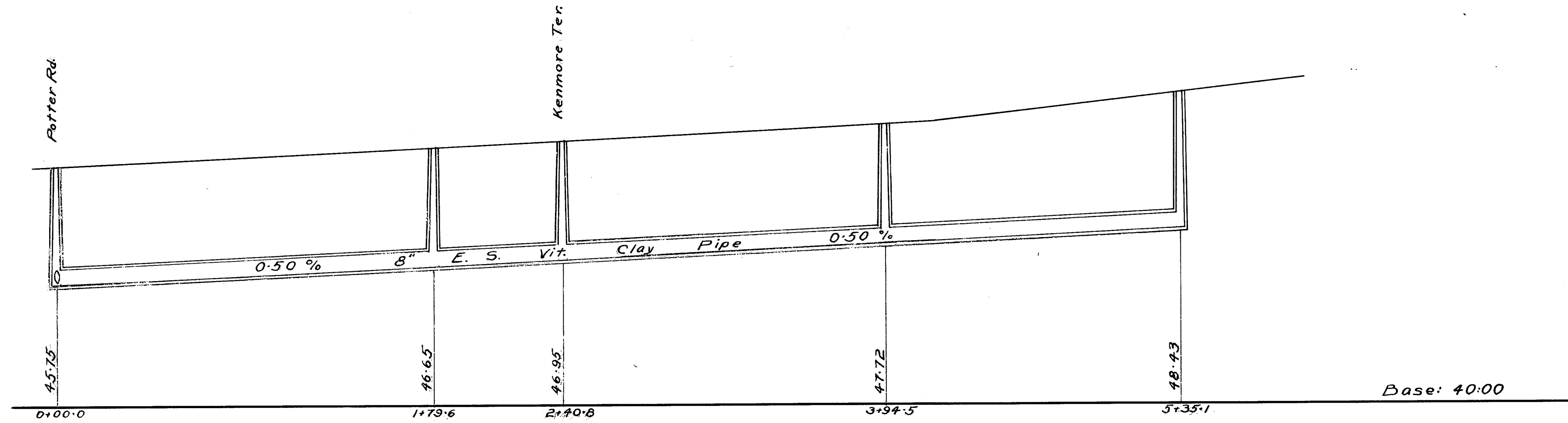

J.E.S.
J.C.

KENMORE ROAD DRAIN

SCALE: 40 FT. HOR. & 4 FT. VERT. PER INCH.

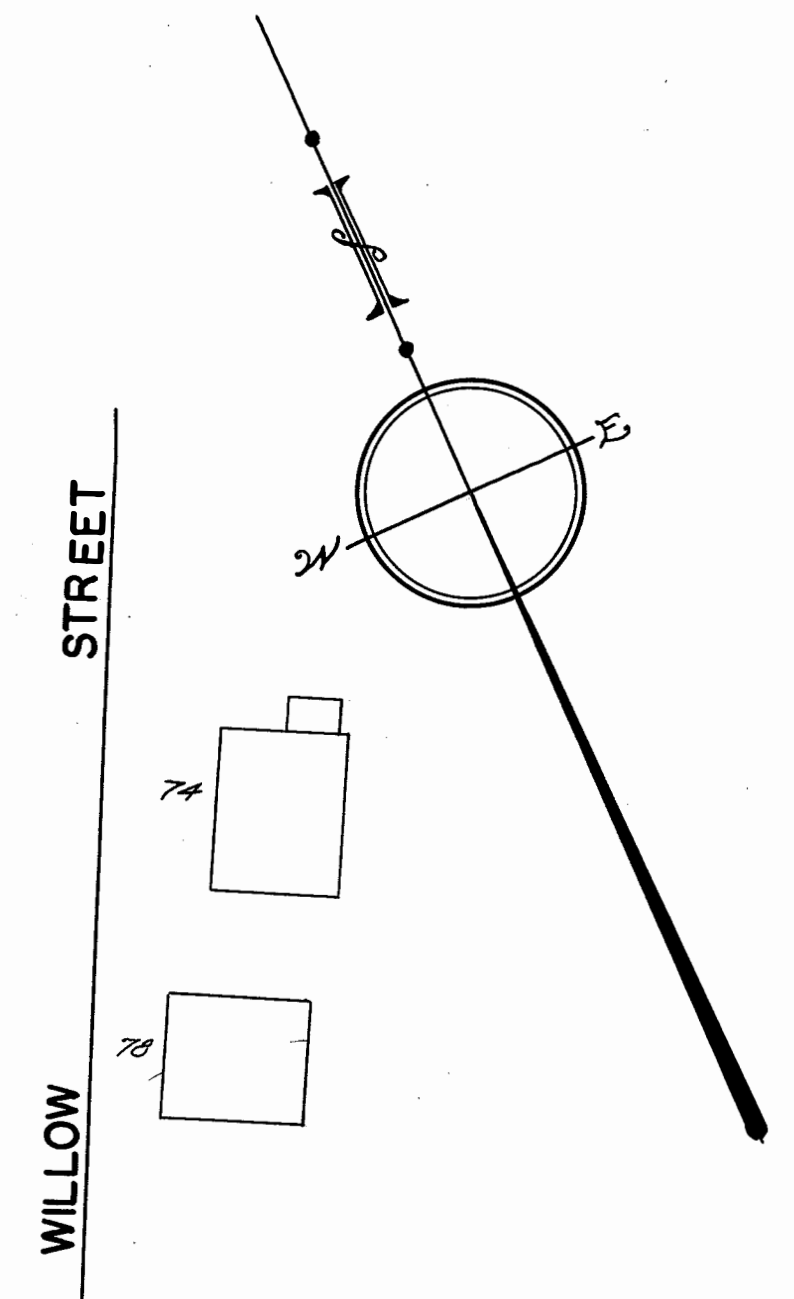
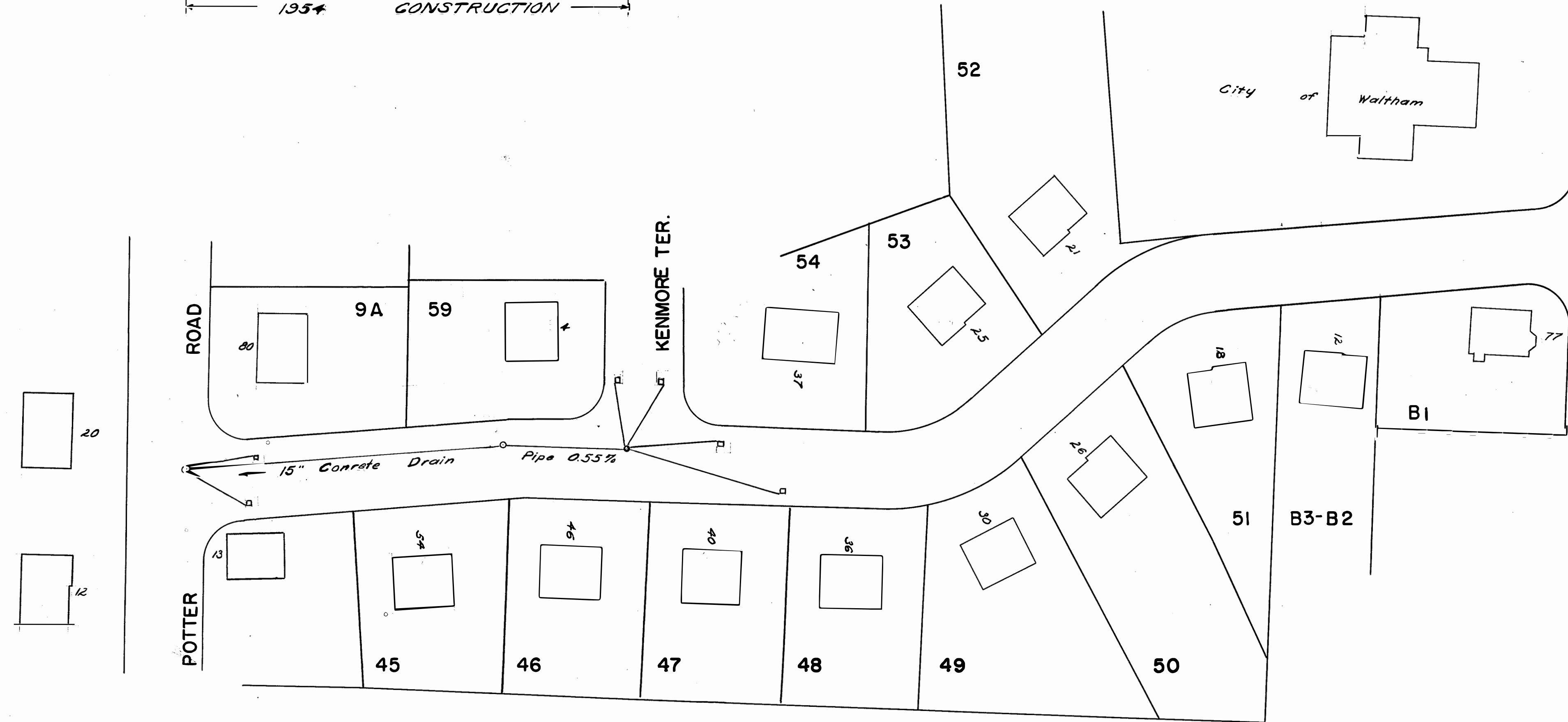
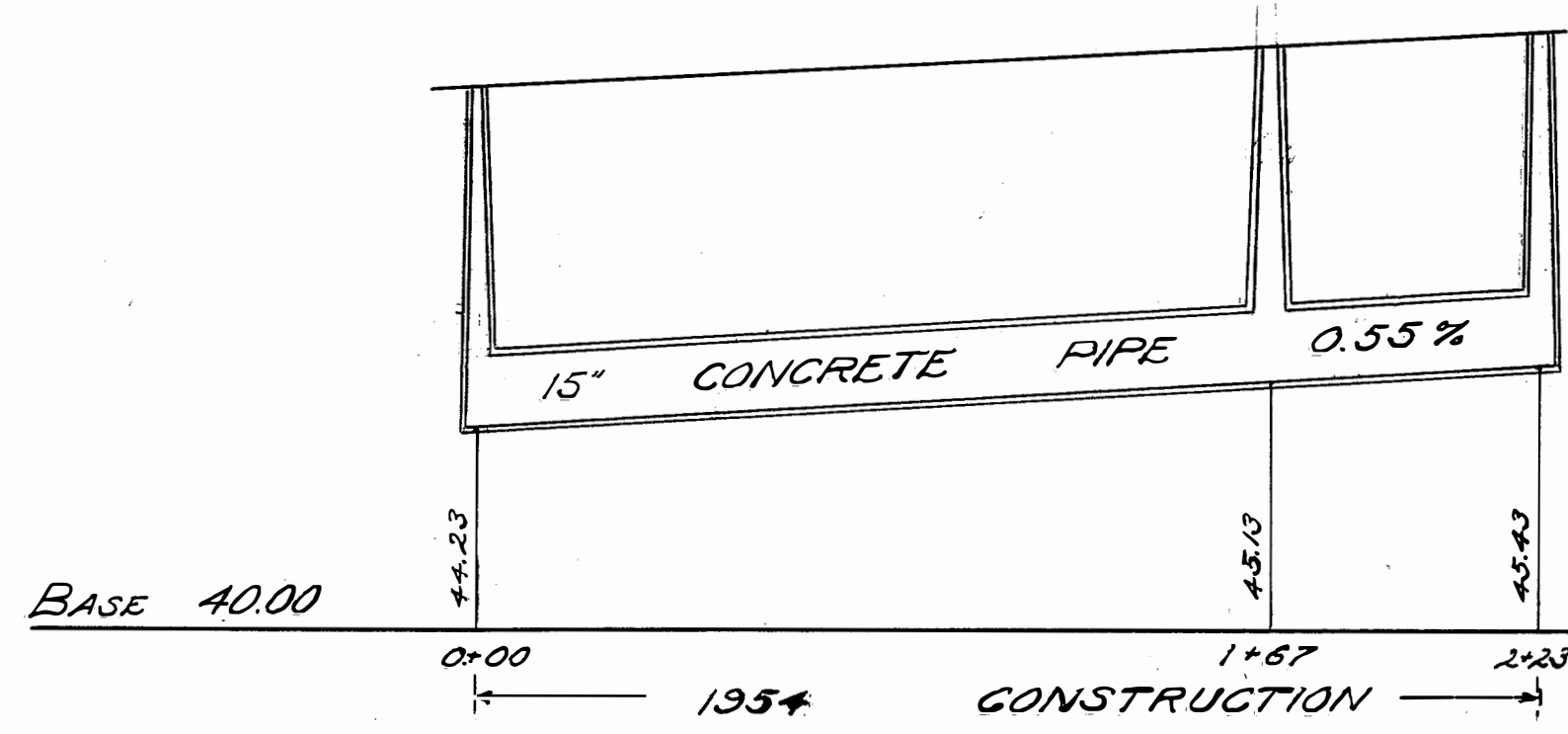

ATTACHMENT D- SERVICE CARDS

NO. 4 Kenmore Terrace SERVICE NO. 10132W

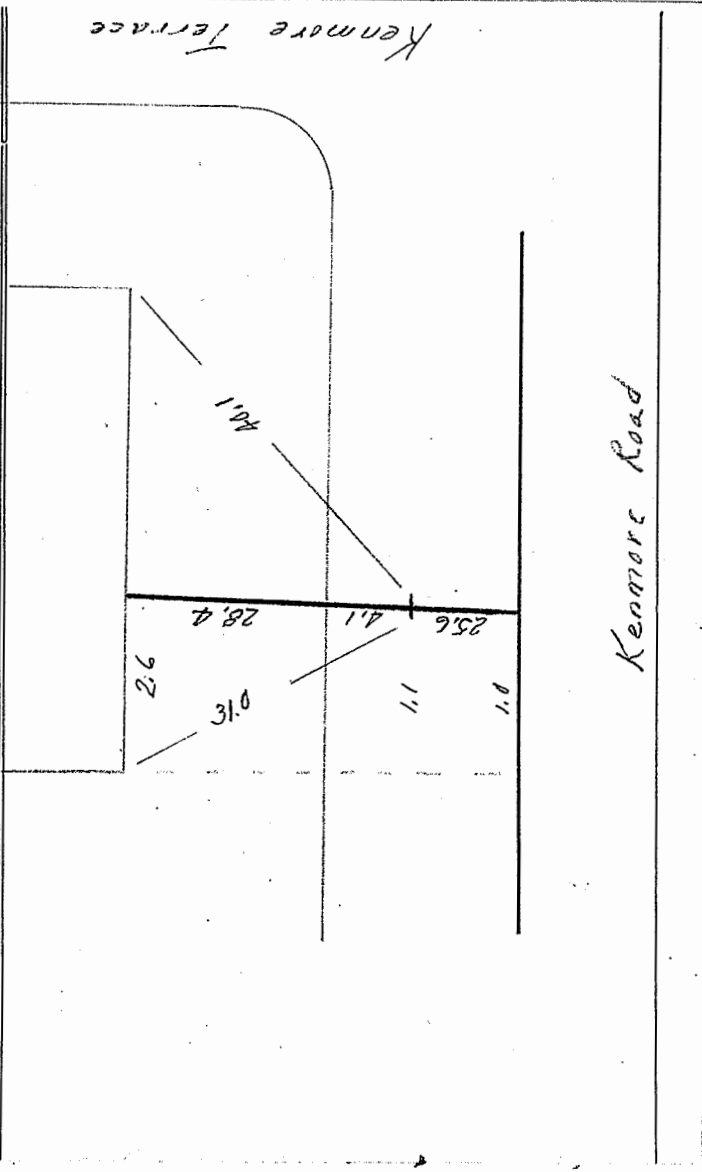

NO. 4 Kenmore Terrace SERVICE NO. 75685

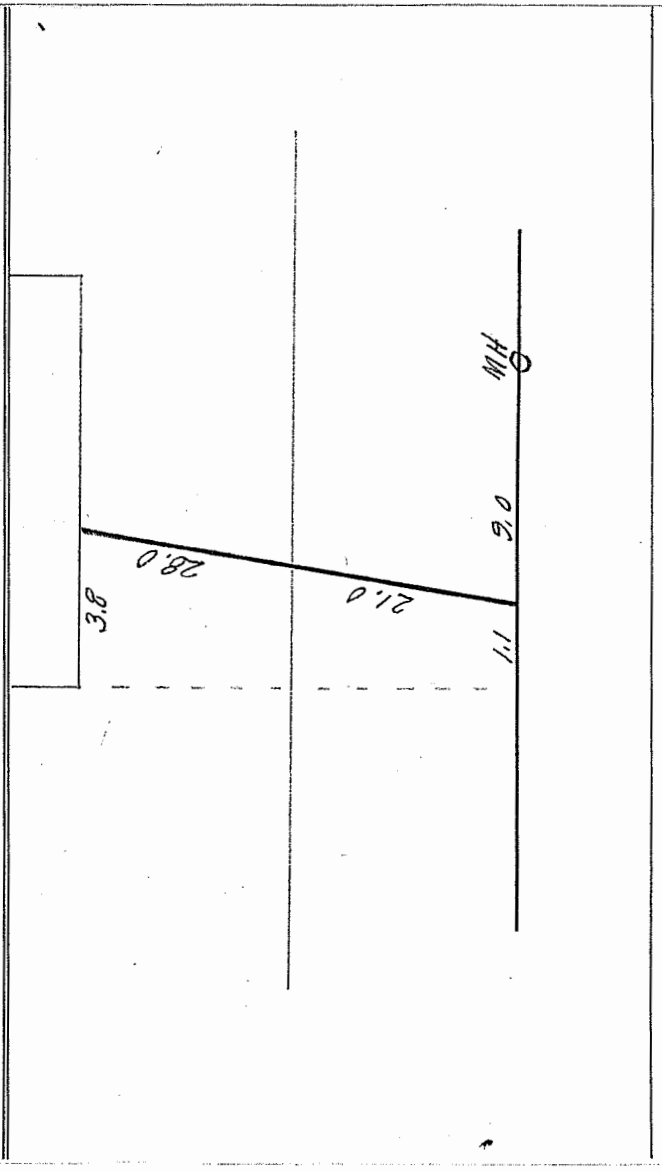

NO 10 KENMORE TER

SERVICE NO 10280-W

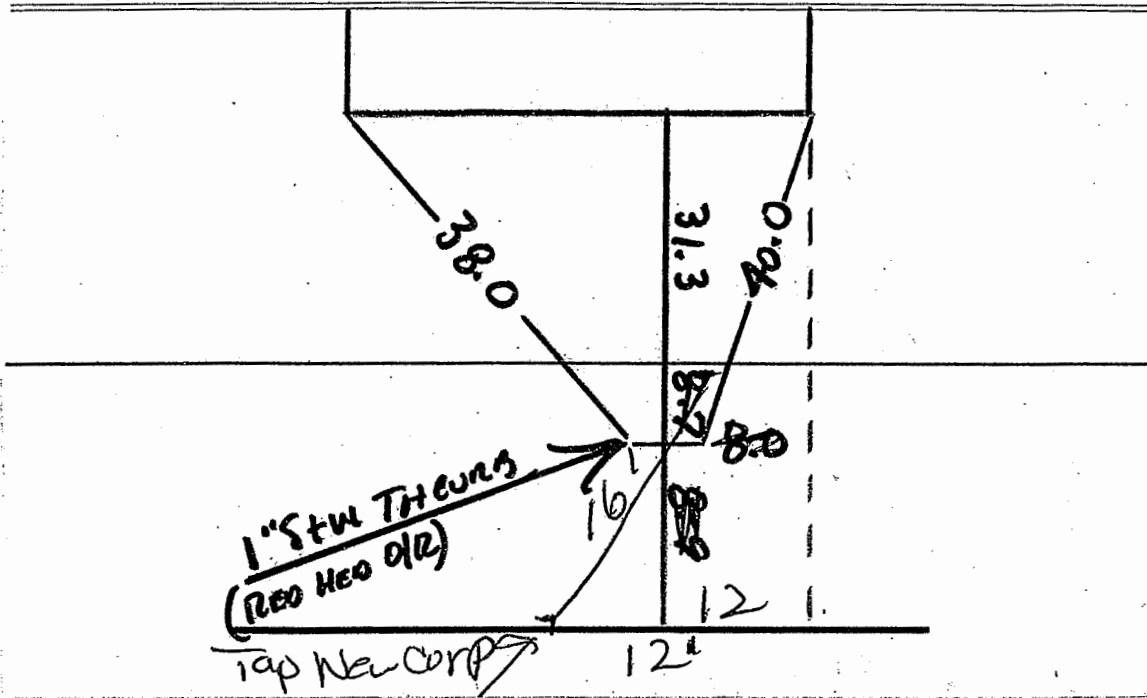

3/7/77 REPAIRED ON PROPERTY AT UNION

(1) 1" 2 BOLT CLAMP

6/4/87 REPAIRS - MAIN TOWERS (REQ)

(1) 1" COPPER KNULE ADAPTER (1) 1" COPPER CORPORATION ADAPTER NEW 1" STW TRENCH (REQ) O/R

(1) 1" TELSCO ADAPTER (DRESSER STYLE) (LEADPO SERVICE

6/12/19 - Tap New curb on main web' New 1" copper new curb

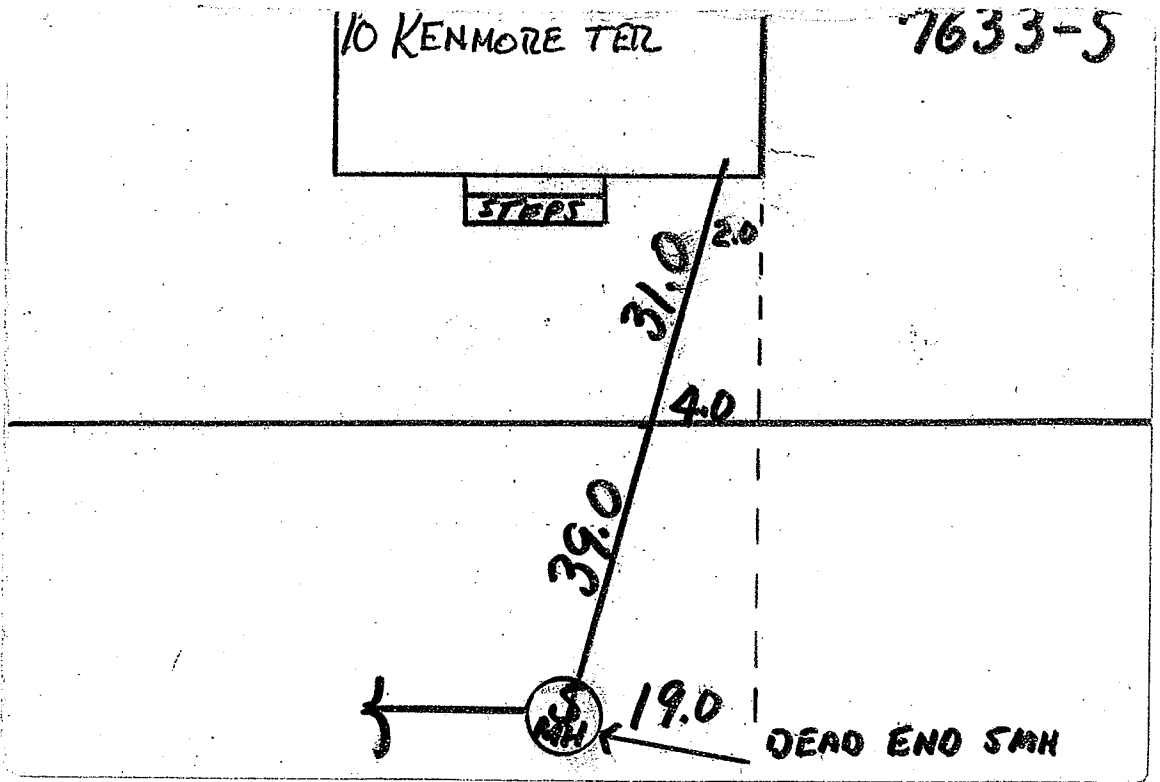

NO. 10 KENMORE TER SERVICE NO. 7633-5

6/12/09 relay main to property line
 4" PVC 39'

SS
 *NEW DIAGRAM + TIES

6/21/20 - Sewer stoppage (grease)
 3/13/19 sewer stoppage (used Jet)
 8/14/80 STOPPAGE - ROOTS
 8/9/81 STOPPAGE - ROOTS (10ft out)
 4/27/82 STOPPAGE - PAPER
 3/11/83 STOPPAGE - DETERGENTS
 7/26/83 STOPPAGE - DETERGENTS
 9/20/83 STOPPAGE - PAPER
 11/1/83 STOPPAGE - PAPER + GRASS
 5/18/84 STOPPAGE - GREASE

1/30/80 **OVER** 11/8/84 STOPPAGE - ROOTS (55ft out)
 2/4/85 STOPPAGE - OIL + SOLVOS (W)
 9/17/85 " " - GREASE + SOLVOS

NO. 11 KENMORE TERR.

SERVICE NO. 7630-S

5-16-2017
RELAY PROPERTY 4" P.V.C
K+D CONST.

5-16-2017 RELAY 4" SEWER MAIN TO PROPERTY

WATER SERVICE 1 FT LEFT OF SEWER LATERAL *

(S)

18.0

4" P.V.C
25.0

4" P.V.C
56.0

NO. 11 KENMORE TERR

SERVICE NO. 10277-W

5-17-2017 RELAY 1"
PROPERTY BY K+D CONST.

5-17-2017 RELAY WATER MAIN TO PROPERTY
16 76' 1" COPPER TUBING

SERVICE FOR # 17
ON TOP OF # 16

* SEWER LATERAL 1 FT *
RIGHT OF WATER

ERIE BOX + ROD (O/L)

CURB NO BOX

GATE

3.6

1" COPPER
25.0

1" COPPER
76.0

10.

87.6

NO. 14 Kenmore Terrace

SERVICE NO. 76325

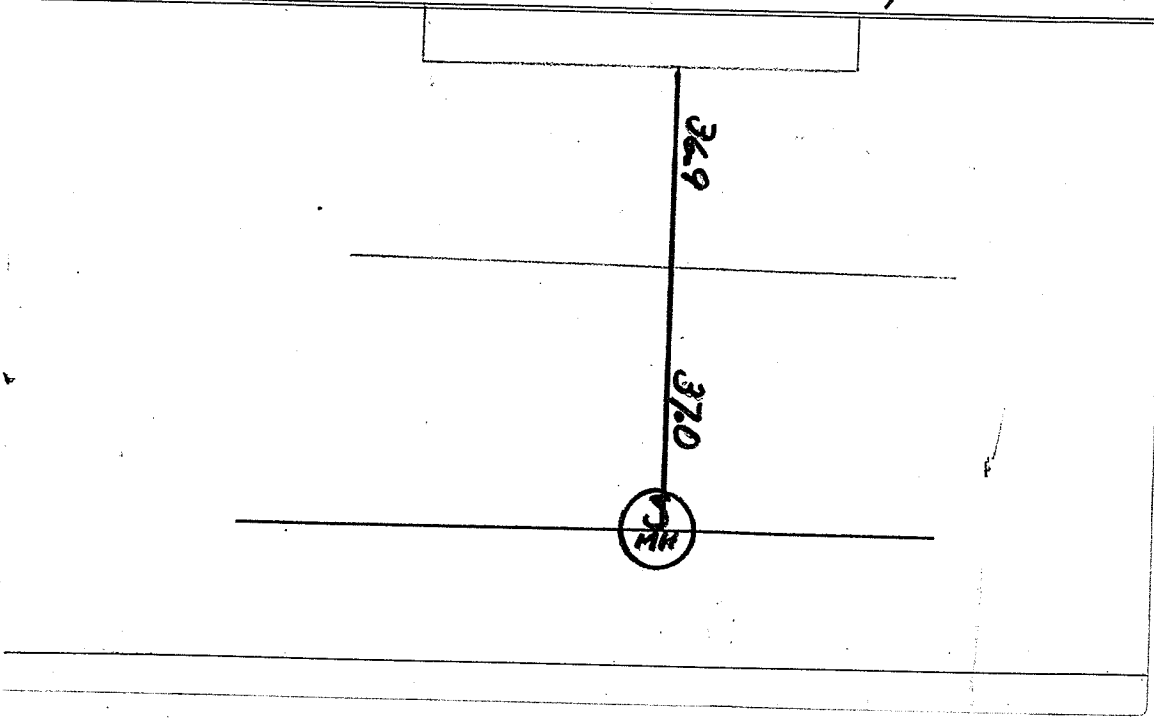

NO. 14 Kenmare Terrace

SERVICE NO. 10279 W

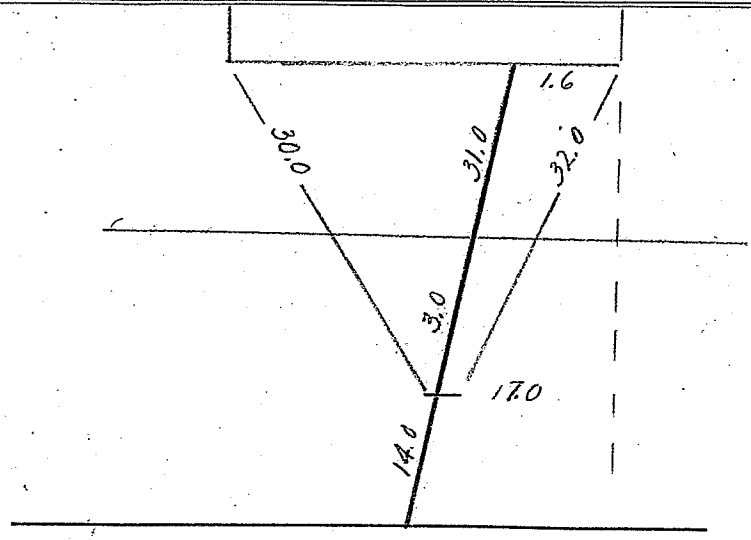

2/25/91 REPLACED LEAD WITH 1" COPPER (385)
COPPER
(1) 1" CORPORATION ADAPTER - (1) 1" BRASS UNIONS - (1) 1" FEMALE ADAPTER
(1) 1" TALSBO ADAPTER (DRESSEN STYLE)
1999 - Replaced property with 1" copper P.W. RYAN

NO. 15 Kenmore Terrace

SERVICE NO. 10278 W

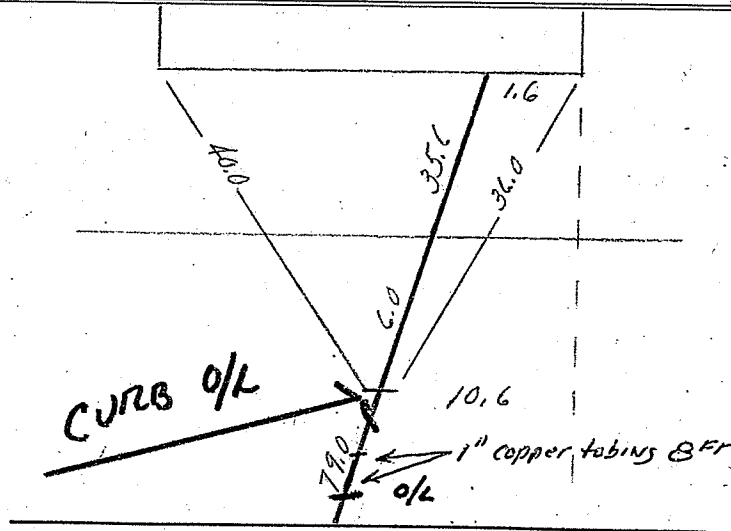

5-16-2017 REPAIR SERVICE IN STREET 8' FROM MAIN, INSTALLED CURB STOP AND 8' 1" COPPER

11/18/66 REPAIRED AT WALL

4/5/73 REPAIRED PIPE IN STREET (2) 1" 2 BOLT CLAMP

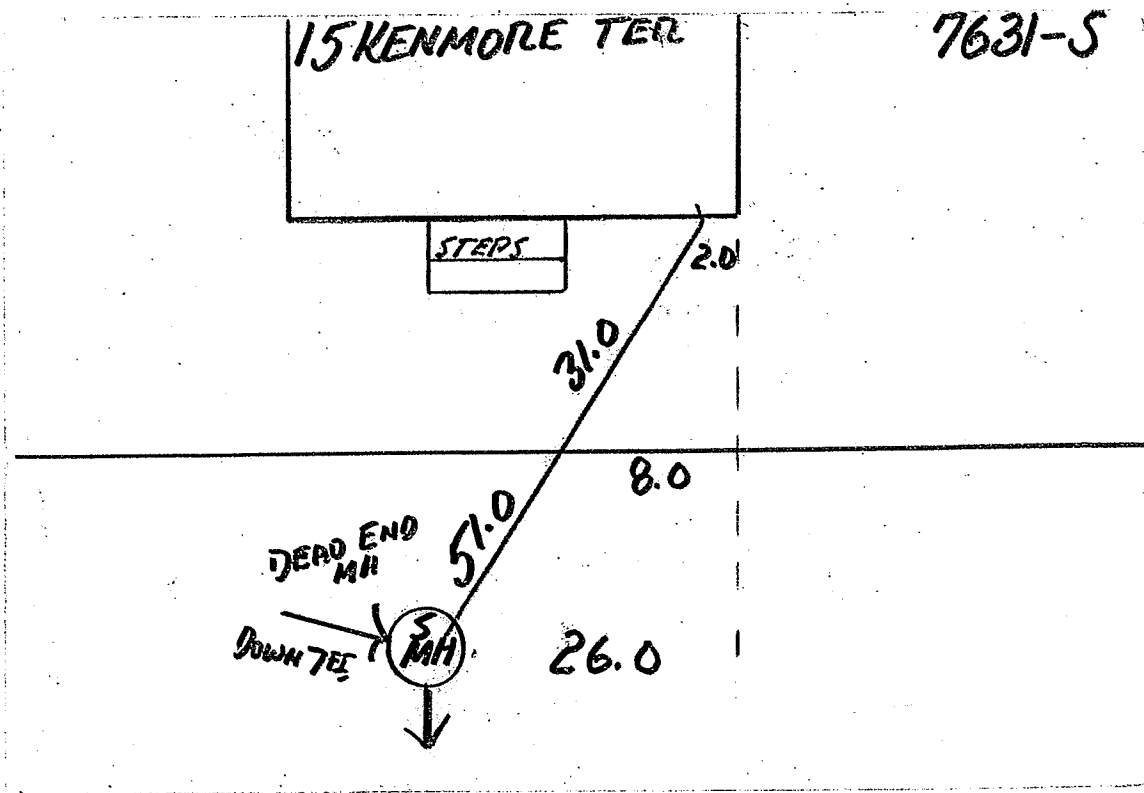

7631-5

NO. 15 KENMORE TER SERVICE NO. 7631-5

SS

*NEW Diagram + TIES

- 4/7/80 STOPPAGE - ROOTS (SEE OUT)
- 11-80 STOPPAGE SOLIDS + DETERGENTS
- 12/14/80 " SOLIDS + GRASS
- 12/22/89 STOPPAGE - SOLIDS + DETERGENT
- 12/31/91 " - SOLIDS
- 4/27/19 " - paper on table
- 5/27/19 - relay property

4/7/80

OVER line to manhole,
now 4" PVC SI